





# South Beloit, Illinois MANUFACTURING FACILITY



Our 35,000 square foot manufacturing facility in South Beloit, Illinois currently facilitates engineering, sales, and production, employing over 65 people. The entire facility is climate and humidity controlled, and has received unconditional lab and factory approval by UL/CUL and factory approved by TUV.



Centrally located in the United States, Minarik Drives has the ability to accommodate and service customers more efficiently and logistically. The largest UPS hub in the country is less than 25 miles away, making standard delivery 2-3 days for 38 states.

## CATALOG PAGE LAYOUT

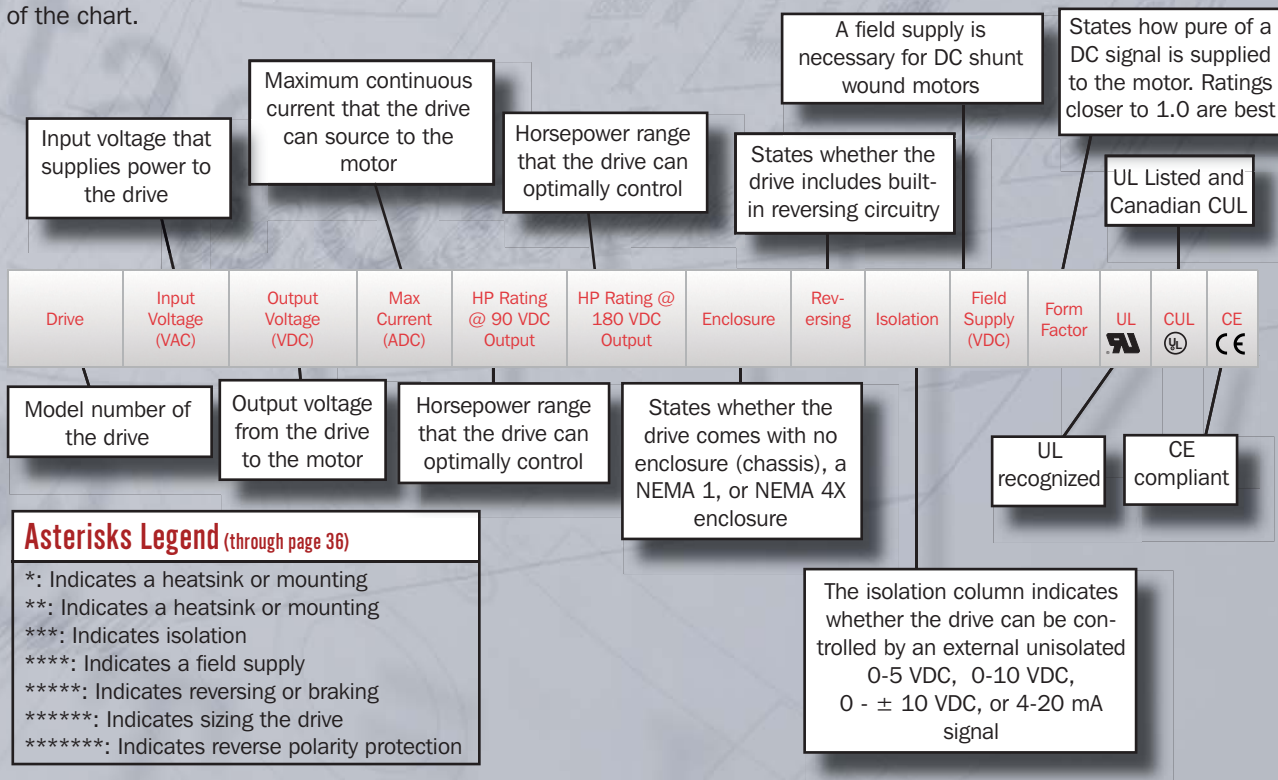
Below is an example of the chart found on a typical catalog page. You will find an explanation of the different parts of the chart.



For More Information:

<b>PHONE</b>  <b>1.800.MINARIK</b> (1.800.646.2745)	<b>FAX</b>  <b>1.800.394.6334</b>	<b>WEB</b>  <a href="http://www.minarikdrives.com">www.minarikdrives.com</a>
---	---	---



# DC DRIVE SELECTION CHART

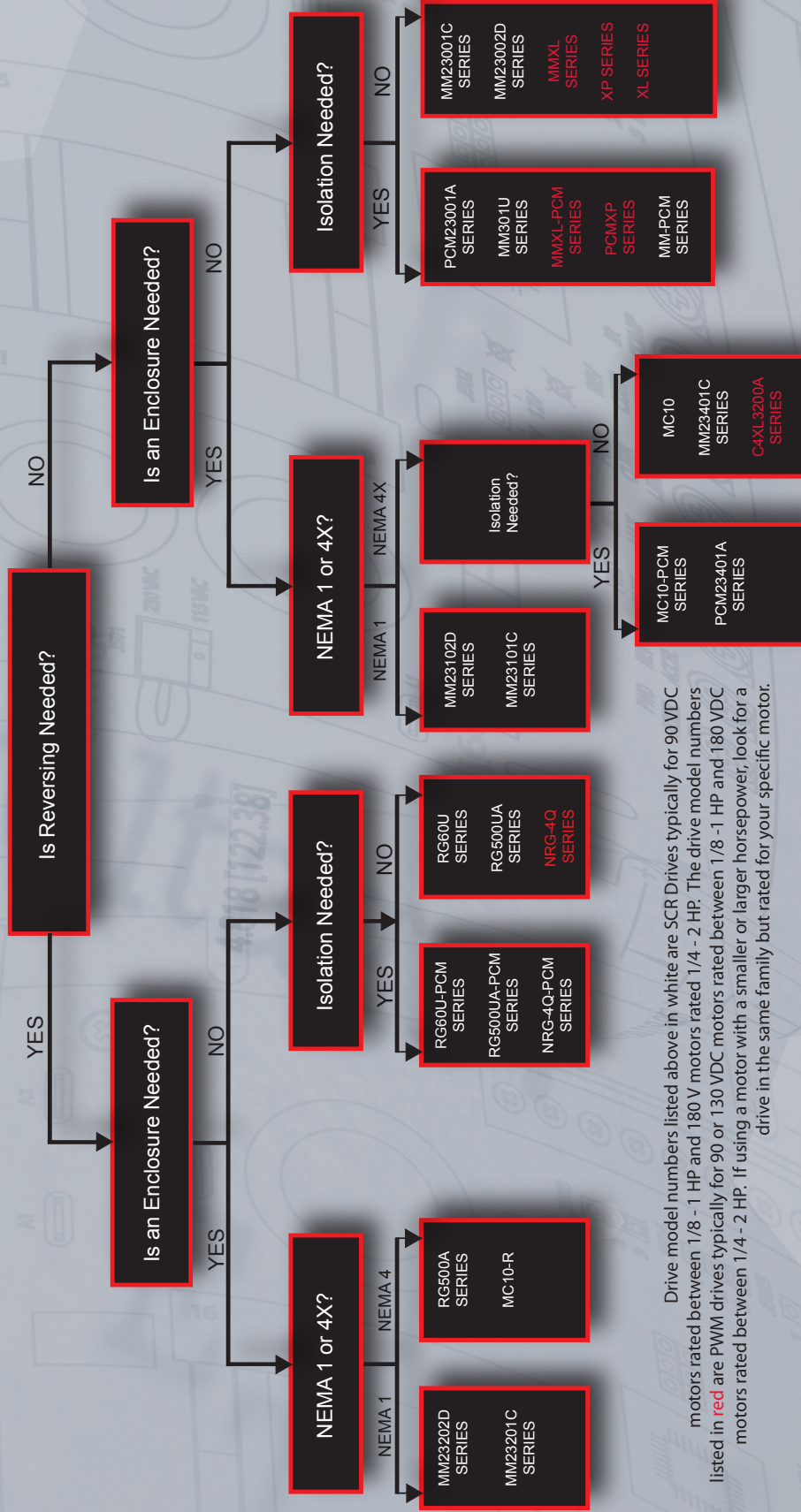

Drive model numbers listed above in white are SCR Drives typically for 90 VDC motors rated between 1/8 - 1 HP and 180 V motors rated 1/4 - 2 HP. The drive model numbers listed in red are PWM drives typically for 90 or 130 VDC motors rated between 1/8 - 1 HP and 180 VDC motors rated between 1/4 - 2 HP. If using a motor with a smaller or larger horsepower, look for a drive in the same family but rated for your specific motor.

# WHAT IS A DRIVE & HOW TO CHOOSE A DRIVE?

The term Motor Drive most commonly refers to an electronic device that controls the speed of a motor. DC Drives control speed by varying DC voltage to a DC motor. AC Drives vary voltage and frequency applied to the AC motor to control speed. A drive is specified based on the application requirements. Subtle differences affect drive selection such as one direction vs. reversing, braking, speed range, regulation ability, enclosures, adjustment trim pots, etc. Select a drive based on the application's requirements and size the drive based on the current (Amp) rating of the motor.

## STEP 1: KNOW YOUR MOTOR

### DC MOTOR

- 90 VDC       130 VDC       180 VDC  
 12/24 VDC       36/48 VDC

- Permanent Magnet       Series Wound  
 Shunt-Wound       Separately Excited

Use 115 VAC input for 90 or 130 VDC motors  
Use 230 VAC input for 180 VDC motors.  
Use PWM drives with 130 VDC motors

### AC MOTOR

- 115 VAC       230 VAC  
 1-phase (specify type below)       3-phase (inverter duty)

- Shaded -Pole      } Speed Controllable  
 Permanent Split Capacitor }  
 Split-Phase      } **NOT** Speed Controllable  
 Capacitor Start      }  
 Capacitor Start, Cap. Run }

MOTOR AMPERAGE: \_\_\_\_\_ (Nameplate rating in Amps)

MOTOR HORSEPOWER: \_\_\_\_\_ HP

## STEP 2: INPUT VOLTAGE TO DRIVE

Input Voltage to Drive: \_\_\_\_\_ (Volts)      AC 1-phase       DC

## STEP 3: KNOW YOUR APPLICATION

### Number of Quadrants<sup>1</sup>:

- 1-quadrant (one direction)       4-quad Regenerative (Forward, Reverse, & Braking)  
(See Sections A & B)      (See Section C)

### Output Technology / Form Factor<sup>1</sup>:

- SCR [best for 50-100% speeds]       PWM [extended speed range, motor runs cooler, longer brush life]  
(See Section A)      (See Sections B & C)

### Control Method:

- Speed pot/knob       External signal (0-10 VDC, ±10 VDC, 4-20 mA) \_\_\_ isolated \_\_\_ non-isolated

### Enclosure Style:

- Open-chassis       NEMA 1 enclosure (finger-safe)       NEMA 4X enclosure (washdown)

### Adjustments Needed:

- Accel/Decel       Min Spd       Max Spd       Current Limit       IR Comp       Other: \_\_\_\_\_

<sup>1</sup> Assumes a DC Drive

# TABLE OF CONTENTS

## **A** SCR DRIVES

- 4 MM23000C Series
- 5 MM23000D Series
- 6 M1 Series
- 7 M2 Series
- 8 PCM20000A Series
- 9 MM Series
- 10 MM-PCM Series
- 11 MM31000 Series
- 12 MC10 Series

## **B** PWM DRIVES

- 13 MMXL Series
- 14 XL Series
- 15 XP Series
- 16 HTL Series
- 17 DC1.5 Family
- 18 LV Family
- 19 DC-DC Family
- 20 DC30 Family
- 21 DC250 Family
- 22 DC500N Family

## **C** REGENERATIVE DRIVES

- 23 RG500A Series
- 24 RG501A Series
- 25 RG60U Series
- 26 RG5500U Series
- 27 NRG-4Q Series

## **D** DC MOTORS

- 28 - 33 Motor Performance Data

## **E** AC DRIVES



- 34 TAI0-D Series
- 35 VFD Series
- 36 VFD-PCM Series
- 37 ACM100 Series
- 38 - 39 AC200 Series
- 40 - 41 AC300 Series

## **F** ACCESSORIES

- 42 DLC Series
- 43 VT8-Series
- 44 PK Series
- 45 Drive Accessories
- 46 - 49 Accessories

## **G** TECHNICAL REFERENCE

- 50 - 53 Drive Comparisons
- 54 - 58 Dimensional Drawings
- 59 - 69 Wiring Diagrams
- 70 - 79 Reference
- 80 - 81 Agency Approvals
- 82 - 83 Glossary
- 84 - 85 Cross Reference
- 86 - 89 Index
- 90 Competitor Cross Reference

Drive	Input Voltage (VAC)	Output Voltage (VDC)	Max Current (ADC)	HP Rating @ 90 VDC Output	HP Rating @ 180 VDC Output	Enclosure	Reversing *****	Isolation	Field Supply (VDC) ****	Form Factor	UL 	CUL 	CE 
MM23011C	115/230	0-90 / 0-180	1.5	1/20 - 1/8	1/10 - 1/4	Chassis	-	***	YES	1.37	YES	YES	YES
MM23111C	115/230	0-90 / 0-180	1.5	1/20 - 1/8	1/10 - 1/4	NEMA 1	-	***	YES	1.37	YES	YES	YES
MM23211C	115/230	0-90 / 0-180	1.5	1/20 - 1/8	1/10 - 1/4	NEMA 1	YES	***	YES	1.37	YES	YES	YES
MM23411C	115/230	0-90 / 0-180	1.5	1/20 - 1/8	1/10 - 1/4	NEMA 4X	-	***	YES	1.37	YES	YES	YES
MM23001C	115/230	0-90 / 0-180	10*	1/8 - 1	1/4-2	Chassis	-	***	YES	1.37	YES	YES	YES
MM23101C	115/230	0-90 / 0-180	10**	1/8 - 1	1/4-2	NEMA 1	-	***	YES	1.37	YES	YES	YES
MM23201C	115/230	0-90 / 0-180	10**	1/8 - 1	1/4-2	NEMA 1	YES	***	YES	1.37	YES	YES	YES
MM23401C	115/230	0-90 / 0-180	10	1/8 - 1	1/4-2	NEMA 4X	-	***	YES	1.37	YES	YES	YES

\* Heatsink number 223-0159 must be used when the output is above 5 Amps.  
 \*\* Heatsink number 223-0174 must be used when the output is above 5 Amps.  
 \*\*\* Built in isolation is not available on the MM23000C family of drives. Minarik Drives recommends using the PCM23001A (Pg 8), MM-PCM (Pg 10), MM300 Series (Pg 9), or PCM4 (Pg 45).  
 \*\*\*\* The field supply is rated at 1 Amp DC. A 50/100 VDC field is available with 115 VAC input, and a 100/200 VDC field is available with 230 VAC input.  
 \*\*\*\*\* Reversing models are designed for occasional reversing and braking using the switches on the enclosure. See Regenerative drives in Section C for drives that can reverse on-the-fly or for drives with the ability to remote mount direction and braking switches.

The MM23000C Series of drives are a reliable and cost-effective solution for controlling your permanent magnet or shunt-wound DC motors in variable-speed applications. The MM23000C series uses SCRs to provide full-wave rectification of the AC line input. These dual voltage drives operate using 115 VAC or 230 VAC, 50/60 Hz, to run 90 or 180 VDC SCR brush-type motors. These drives control motors from 1/20 to 2 HP and come in chassis, NEMA 1, and NEMA 4X models. Cased models include AC line fuses.

See page 50 for an in-depth comparison of the different models of drives.



MM230x1C DIMENSIONS

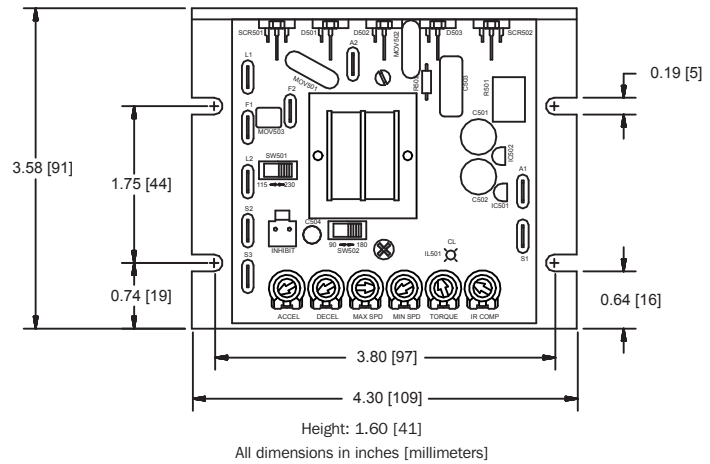

Height: 1.60 [41]  
 All dimensions in inches [millimeters]  
 Dimensions of drives not shown above can be found on page 54.  
 Wiring diagrams of chassis drives can be found on page 59 and 68.

FEATURES

- **MM footprint:** Chassis drives have a compact industry standard footprint.
- **Speed range and regulation:** 1% regulation over 60:1 speed range.
- **User adjustable calibration pots:** IR compensation, min speed, max speed, current limit, acceleration and deceleration.
- **Diagnostic LED:** LED for current limit status on all models. Cased models have a green power light.
- **Stopping Modes:** Inhibit (N/O) for coasting to a stop on all models. Dynamic braking included on MM232x1C.
- **Spade and screw terminals:** Easy to use spade terminals on chassis; screw terminals on enclosed units.
- **Options:** "-Q" option on chassis drives include quick disconnect terminal block and power LED.
- **Accessories:** Heatsink 223-0159 or 223-0174. 201-0024 inhibit plug with 18" leads, DLC600 digital closed loop controller, PCM4 isolation card.

Drive	Input Voltage (VAC)	Output Voltage (VDC)	Max Current (ADC)	HP Rating @ 90 VDC Output	HP Rating @ 180 VDC Output	Enclosure	Reversing *****	Isolation	Field Supply (VDC)	Form Factor	UL	CUL	CE
MM23012D	115/230	0-90 / 0-180	1.5	1/20 - 1/8	1/10 - 1/4	Chassis	-	***	****	1.37	YES	YES	YES
MM23112D	115/230	0-90 / 0-180	1.5	1/20 - 1/8	1/10 - 1/4	NEMA 1	-	***	****	1.37	YES	YES	YES
MM23212D	115/230	0-90 / 0-180	1.5	1/20 - 1/8	1/10 - 1/4	NEMA 1	YES	***	****	1.37	YES	YES	YES
MM23412D	115/230	0-90 / 0-180	1.5	1/20 - 1/8	1/10 - 1/4	NEMA 4X	-	***	****	1.37	YES	YES	YES
MM23002D	115/230	0-90 / 0-180	10*	1/8 - 1	1/4 - 2	Chassis	-	***	****	1.37	YES	YES	YES
MM23102D	115/230	0-90 / 0-180	10**	1/8 - 1	1/4 - 2	NEMA 1	-	***	****	1.37	YES	YES	YES
MM23202D	115/230	0-90 / 0-180	10**	1/8 - 1	1/4 - 2	NEMA 1	YES	***	****	1.37	YES	YES	YES
MM23402D	115/230	0-90 / 0-180	10	1/8 - 1	1/4 - 2	NEMA 4X	-	***	****	1.37	YES	YES	YES

\* Heatsink number 223-0159 must be used when the output is above 5 Amps.  
 \*\* Heatsink number 223-0174 must be used when the output is above 5 Amps.  
 \*\*\* Built in isolation is not available on the MM23000D family of drives. Minarik Drives recommends using the PCM23001A (pg 8), MM-PCM (pg 10), MM300 Series (pg 9), or PCM4 (pg 45).  
 \*\*\*\* The field supply is not available on the MM23000D family of drives. Minarik Drives recommends using the MM23000C Series (pg 4).  
 \*\*\*\*\* Reversing models are designed for occasional reversing and braking using the switches on the enclosure. See Regenerative drives in Section C for drives that can reverse on-the-fly or for drives with the ability to remote mount direction and braking switches.

**MM230x2D DIMENSIONS**

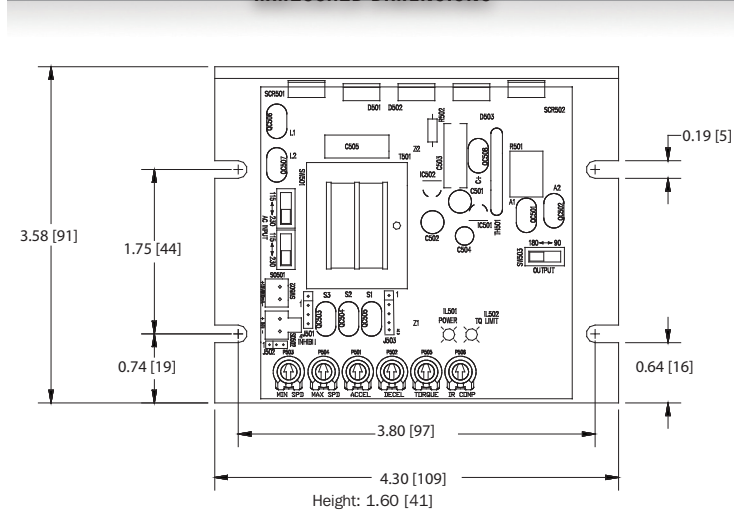

All dimensions in inches [millimeters]  
 Dimensions of drives not shown above can be found on page 54.  
 Wiring diagrams of chassis drives can be found on page 59 and 68.

**FEATURES**

- **MM footprint:** Chassis drives have a compact industry standard footprint.
- **Speed range and regulation:** 1% regulation over 60:1 speed range.
- **User adjustable calibration pots:** IR compensation, min speed, max speed, torque, acceleration and deceleration.
- **Diagnostics:** LEDs for power and current limit status.
- **Stopping modes:** Coast to minimum speed or to stop with selectable N.O. or N.C. inhibit contacts. Dynamic braking included on MM232x2D.
- **Spade and screw terminals:** Easy to use spade terminals on chassis; screw terminals on enclosed units.
- **Speed or torque control:** Choose operating mode using jumper pins.
- **Accessories:** Heatsink 223-0159 or 223-0174. 201-0024 inhibit plug with 18" leads, DLC600 digital closed loop controller, PCM4 isolation card.

The MM23000D Series is similar to the MM23000C Series except for the addition of the following features. The MM23000D Series has a flexible inhibit circuit that can be set for a normally open or normally closed input. A torque mode option was also added to this family of drives where the drive will control the current to the motor, perfect for tension control applications. The logic circuit in the MM23000D Series contains additional filtering that allows the drive to run better and longer in electrically noisy environments. Also the MM23000D Series can accept a 5K or 10K Ohm potentiometer and that allows the drive to be a drop in replacement for many competitor drives.

Choose the MM23000D Series for the best **value** single quadrant SCR drive on the market.

See page 50 for an in-depth comparison of the different models of drives.



MM23002D  
 MM23012D

MM23102D  
 MM23112D



MM23202D  
 MM23212D



MM23402D  
 MM23412D

Drive	Input Voltage (VAC)	Output Voltage (VDC)	Max Current (ADC)	HP Rating @ 90 VDC Output	HP Rating @ 180 VDC Output	Enclosure	Reversing	Isolation	Field Supply (VDC)	Form Factor	UL	CUL	CE
M1	115	0-90	10*	1/15 - 1	–	Chassis	*****	***	****	1.37	YES	YES	–

\* Heatsink number 223-0159 must be used when the output is above 5 Amps.  
 \*\*\* Built in isolation is not available on the M1. Minarik Drives recommends using the PCM23001A (pg 8), MM-PCM (pg 10), MM300 Series (pg 9), or PCM4 (pg 45).  
 \*\*\*\* The field supply is not available on the M1. Minarik Drives recommends using the MM23000C Series (pg 4).  
 \*\*\*\*\* See Regenerative Drives in Section C for drives that can reverse on-the-fly.

The size and the design of the M1 set it apart from the other SCR chassis drives. The very compact M1 has a footprint of only 4.30" x 2.64" while maintaining the industry standard MM mounting hole location.

The M1 is a microprocessor based design which allows the drive to be more flexible. Adjustments such as the acceleration, deceleration, torque limit, and IR compensation can be factory programmed for OEMs. The microprocessor also allows for increased performance over a wider range of motor sizes.

The microprocessor on the M1 also makes the drive more intelligent than competitor SCR drives. For example, assume a motor stalls because of a jam. The M1 will allow the motor to ramp up to speed based on the acceleration setting once the jam is removed. Competitor drives would have immediately supplied full voltage to the motor once the jam was removed, and not followed the acceleration setting. Features such as this make the M1 a safer and more reliable drive.

The compact size and additional features of the M1 make it an excellent choice for those looking for power and performance in a small package.

See page 50 for an in-depth comparison of the different models of drives.



M1

**M1 DIMENSIONS**

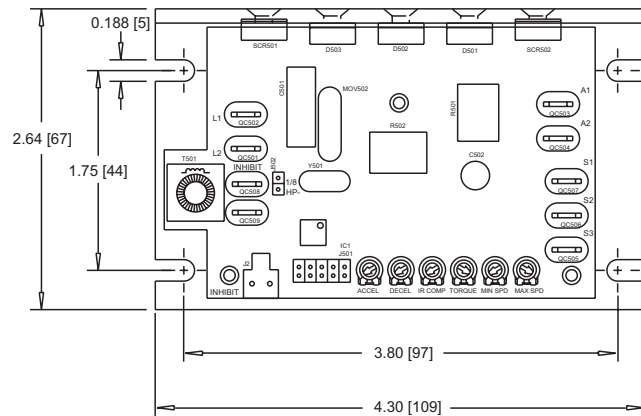

All dimensions in inches [millimeters]

Wiring diagrams of chassis drives can be found on page 59 and 68.

**FEATURES**

- **Compact size:** Standard “MM” mounting hole locations but with only a 4.30” x 2.64” footprint.
- **Speed range and regulation:** 1% regulation over 60:1 speed range.
- **User adjustable calibration pots:** IR compensation, max speed, min speed, acceleration, deceleration and torque limit.
- **Stopping modes:** Inhibit (N/O) for coasting to a stop.
- **Spade terminals:** Easy to use, lower cost and able to fit in a smaller package.
- **Two choices for inhibit connection:** Remote start/stop control with an inhibit plug or simply connect to spade terminals.
- **Programmable trimmer pot ranges:** Unique application requirements for acceleration, deceleration, torque limit and IR compensation can be programmed into a chip without expensive hardware changes.
- **Additional features:** Wider than typical IR comp range for finer tuning, wide accel/decel range (0.5 to 26 secs), and vibration tested to 1G.
- **Accessories:** Heatsink 223-0159. 201-0024 inhibit plug with 18” leads, DLC600 digital closed loop controller, PCM4 isolation card.



Drive	Input Voltage (VAC)	Output Voltage (VDC)	Max Current for each motor   both motors total	HP Rating @ 90 VDC each side   both sides total HP	HP Rating @ 180 VDC each side   both sides total HP	Enclosure	Reversing	Isolation	Field Supply (VDC)	Form Factor	UL	CUL	CE
M2	115	0-90	6.5*   11.5*	1/15 -1   1 1/8	–	Chassis	–	***	****	1.37	YES	YES	–
M2-D	115/230	0-90 / 0-180	6.5*   11.5*	1/15 -1   1 1/8	1/8 - 2   2 1/4	Chassis	–	***	****	1.37	YES	YES	–

\* Heatsink number 223-0159 must be used when one motor is above 5 Amps, or the total of both motors combined is above 6.5 Amps. Motor A ≤ 10 Amps; Motor B ≤ 10 Amps; Motor A + Motor B ≤ 11.5 Amps  
 \*\*\* Built in isolation is not available on the M2 family of drives. Minarik Drives recommends using the PCM23001A (pg 8), MM-PCM (pg 10), MM300 Series (pg 9), or PCM4 (pg 45).  
 \*\*\*\* The field supply is not available on the M2 family of drives. Minarik Drives recommends using the MM23000C Series (pg 4).

**M2-D DIMENSIONS**

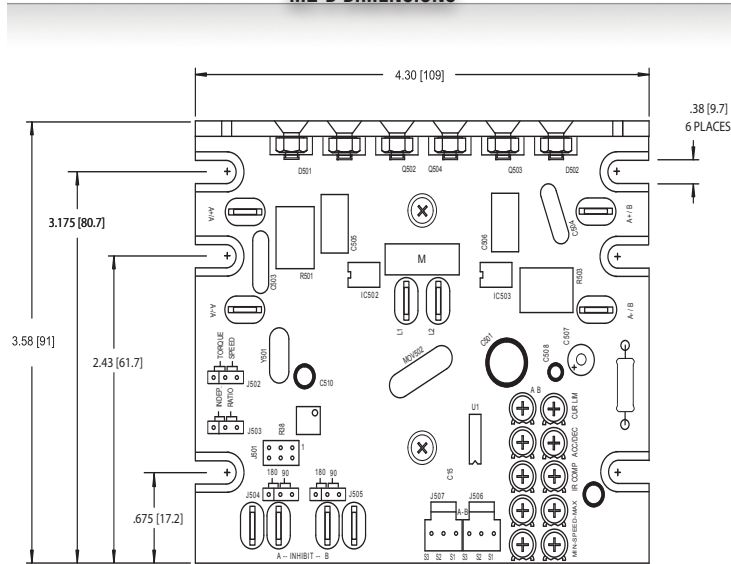

Height: 1.41 [36]

All dimensions in inches [millimeters]

Dimensions of drives not shown above can be found on page 54.  
 Wiring diagrams of chassis drives can be found on page 59 and 68.

**FEATURES**

- **Ability to control two different DC motors at once:** Jumper selectable independent or speed ratio mode.
- **MM footprint:** A compact industry standard footprint.
- **Speed range and regulation:** 1% over 60:1 speed range.
- **User adjustable calibration pots:** Two each of minimum speed, maximum speed, IR compensation, current limit and acceleration/deceleration
- **Stopping modes:** Inhibit (N/O) for coasting to a stop.
- **Spade terminals:** Allows for quick and easy terminations and changes.
- **Panel space saving:** Replace two DC drives with one compact package.
- **Speed or Torque mode:** Jumper selectable. Speed mode regulates speed and limits current. Torque mode regulates current and limits speed.
- **Microprocessor based:** Can custom program the trimmer pot ranges and inhibit (N/O or N/C) for OEM applications.
- **Accessories:** Heatsink 223-0159. DLC600 digital closed loop controller, PCM4 isolation card.

The M2 Series provides the power of two drives in one! Now with one DC drive, you can control two different DC motors either independently or in a ratio mode. In independent mode, each side of the drive can be controlled independently from the other motor. There are two unique sets of trimmer pots for calibration. In speed ratio mode, one speed potentiometer sets the main speed while the other one determines the ratio of the speeds between the motors. In this mode, the drive replaces two single drives and possibly a separate master/follower card resulting in extreme cost and panel space savings!

The M2 Series is easy to set up with simple jumpers to choose the speed/torque and independent/ratio modes. Set up parameters are easily adjusted with on board trimmer pots. For OEMs that have fixed settings, the M2 Series is microprocessor based and can have the settings or ranges of the trimmer pots and other functions customized without any hardware changes!

The M2 Series is ideal for applications with two DC motors that are working together, two motors that run independently but are physically close, or simply when panel space is very limited.

See page 50 for an in-depth comparison of the different models of drives.

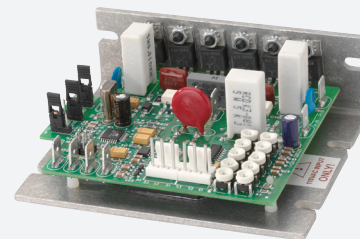

M2

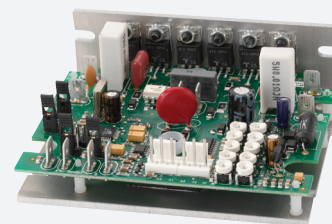

M2-D

Drive	Input Voltage (VAC)	Output Voltage (VDC)	Max Current (ADC)	HP Rating @ 90 VDC Output	HP Rating @ 180 VDC Output	Enclosure	Reversing	Isolation	Field Supply (VDC) ****	Form Factor	UL	CUL	CE
PCM21010A	115	0-90	2	1/20 - 1/8	-	Chassis	*****	0-10 VDC	-	1.37	YES	-	YES
PCM23411A	115 / 230	0-90 / 0-180	3	1/20 - 1/8	1/8 - 1/4	NEMA 4X	*****	0-10 VDC / 4-20 mA	YES	1.37	-	-	YES
PCM21000A	115	0-90	10*	1/4 - 1	-	Chassis	*****	0-10 VDC	-	1.37	YES	-	YES
PCM22000A	230	0-180	10*	-	1/2 - 2	Chassis	*****	0-10 VDC	-	1.37	YES	-	YES
PCM23001A	115 / 230	0-90 / 0-180	10	1/8 - 1	1/4 - 2	Chassis	*****	0-10 VDC / 4-20 mA	YES	1.37	YES	-	YES
PCM23401A	115 / 230	0-90 / 180	10	1/8 - 1	1/4 - 2	NEMA 4X	*****	0-10 VDC / 4-20 mA	YES	1.37	YES	-	YES

\* Heatsink number 223-0159 must be used when the output is above 5 Amps.

\*\*\*\* The field supply is rated at 1 Amp DC. A 50/100 VDC field is available with 115 VAC input, and a 100/200 VDC field is available with 230 VAC input.

\*\*\*\*\* See Regenerative drives in Section C for drives that can reverse on-the-fly.

The PCM20000A Series of drives are a cost-effective solution for variable speed, process control applications from 1/20 to 2 HP. These are SCR drives that integrate isolation allowing them to accept external analog process control signals. Alternative solutions require users to wire a separate isolation card to the drive which adds cost and reduces available space.

Users can operate the drives in manual mode using normal potentiometer operation or in signal mode where drive output is proportional to an external signal input. Additionally, the PCM23xx1A has a signal ratio mode which allows the potentiometer to scale the output voltage while the external signal is the main control source. It comes with a quick connector for wiring between the three operation modes.

See page 50 for an in-depth comparison of the different models of drives.



PCM23001A DIMENSIONS

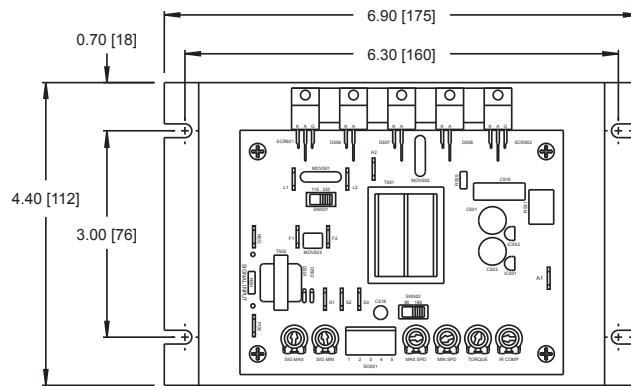

Height: 2.30 [58]

All dimensions in inches [millimeters]

Dimensions of drives not shown above can be found on pages 54 and 55. Wiring diagrams of chassis drives can be found on pages 59, 60, and 68.

FEATURES

- **MM Footprint:** PCM2x0x0A have a compact industry standard footprint.
- **Isolated inputs:** Accepts floating or grounded speed reference signals of 0-10VDC or 4-20mA. 3% linearity through 50:1 speed range (60:1 for PCM23001A). 1% linearity through 30:1 speed range.
- **Speed range and regulation:** 1-2% regulation over 50:1 (60:1 for PCM23001A) speed range.
- **User adjustable calibration pots:** IR compensation, min speed, max speed, current limit, signal max adjust, and signal min (PCM23xxxA only).
- **Spade and screw terminals:** Easy to use spade terminals on chassis; screw terminals on enclosed units.
- **Additional features:** Manual or signal mode jumper select.
- **Additional features (PCM23xx1A only):** Third mode of signal input with ratio output, dual voltage AC input, DC field voltage.

Drive	Input Voltage (VAC)	Output Voltage (VDC)	Max Current (ADC)	HP Rating @ 90 VDC Output	HP Rating @ 180 VDC Output	Enclosure	Reversing	Isolation	Field Supply (VDC) ****	Form Factor	UL	CUL	CE
MM311U	115/230	0-90 / 0-180	1.5	1/20 - 1/8	1/10 - 1/4	Chassis	*****	0-10 VDC / 4-20 mA	YES	1.37	YES	YES	YES
MM301U	115/230	0-90 / 0-180	10	1/4 - 1	1/2 - 2	Chassis	*****	0-10 VDC / 4-20 mA	YES	1.37	YES	YES	YES
MM501U	115/230	0-90 / 0-180	25	1 - 2 1/2	2 - 5	Chassis	*****	0-10 VDC / 4-20 mA	YES	1.37	YES	YES	-

\*\*\*\* The MM3x1U field supply is rated at 1 Amp DC while the MM501U field supply is rated at 3 Amp. A 50/100 VDC field is available with 115 VAC input, and a 100/200 VDC field is available with 230 VAC input.  
\*\*\*\*\* See Regenerative Drives in Section C for drives that can reverse on-the-fly.

### MM3x1U DIMENSIONS

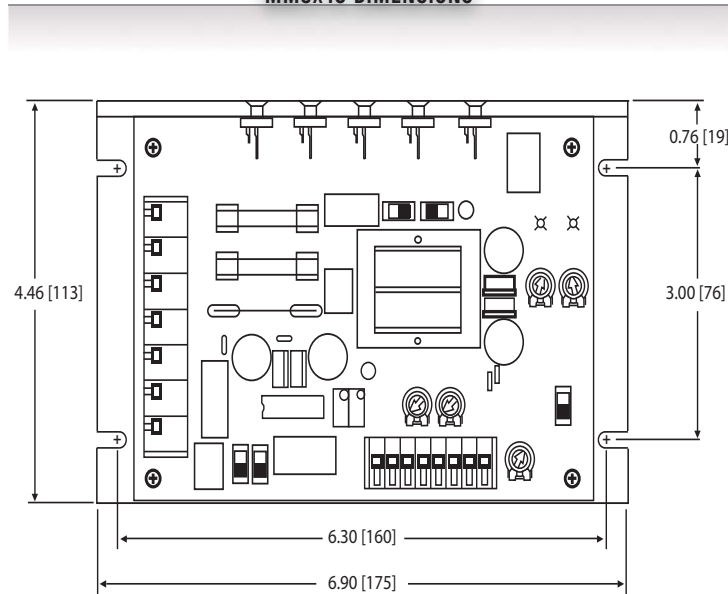

Height: 1.90 [48]

All dimensions in inches [millimeters]

Dimensions of drives not shown above can be found on page 55.  
Wiring diagrams of chassis drives can be found on pages 60 and 68.

### FEATURES

- **Isolated inputs:** Accepts floating or grounded signals of 0-10VDC or 4-20mA for controlling the speed of the motor. Burr-Brown isolation provides .01% linearity.
- **Speed range and regulation:** 1% regulation over 60:1 speed range. 0.1% regulation over 80:1 speed range with the addition of a tachometer for feedback.
- **User adjustable calibration pots:** IR compensation, min speed (12 turn), max speed (12 turn), current limit, acceleration, deceleration and tachometer.
- **Diagnostic LEDs:** LEDs for power, run (MM501U only) and current limit status.
- **Stopping modes:** Start/stop circuitry for three wire remote pushbuttons or two wire maintained switches.
- **Cage clamp terminal block:** Quick and easy wire terminations reduce installation time!
- **Additional features:** Tachometer feedback mode and on board fusing.

The MM300 and MM500 Series of dual-voltage single quadrant SCR drives can control 90 or 180 VDC SCR brush-type motors ranging from 1/20 HP through 5 HP. The MM311U, MM301U, and the MM501U drives have integrated isolation allowing them to precisely follow analog current or voltage signals from external devices or a potentiometer as a reference for motor speed control. This results in significant labor and material cost reduction compared to other systems employing a separate drive and isolation card.

Use the MM300 or MM500 Series for a full featured, high end, great performing single quadrant DC drive.

See page 50 for an in-depth comparison of the different models of drives.



MM301U  
MM311U



MM501U

Drive	Input Voltage (VAC)	Output Voltage (VDC)	Max Current (ADC)	HP Rating @ 90 VDC Output	HP Rating @ 180 VDC Output	Enclosure	Reversing	Isolation	Field Supply (VDC) ****	Form Factor	UL	CUL	CE
MM03-115AC-PCM	115	0-90	3	1/50 - 1/8	-	Chassis	*****	0-10 VDC / 4-20 mA	YES	1.37	YES	YES	YES
MM03-230AC-PCM	230	0-180	3	-	1/25 - 1/4	Chassis	*****	0-10 VDC / 4-20 mA	YES	1.37	YES	YES	YES
MM10-115AC-PCM	115	0-90	10*	1/8 - 1	-	Chassis	*****	0-10 VDC / 4-20 mA	YES	1.37	YES	YES	YES
MM10-230AC-PCM	230	0-180	10*	-	1/4 - 2	Chassis	*****	0-10 VDC / 4-20 mA	YES	1.37	YES	YES	YES

\* Heatsink number 223-0159 must be used when the output is above 5 Amps.

\*\*\*\* The field supply is rated at 1 Amp DC. A 50/100 VDC field is available with 115 VAC input, and a 100/200 VDC field is available with 230 VAC input.

\*\*\*\*\* See Regenerative Drives in Section C for drives that can reverse on-the-fly.

Similar to our MM23001C Series in length and width, the “piggyback” design allows for many additional features in a small package.

The MM-PCM Series drive accepts non-isolated voltage (0-10VDC) or current (4-20mA) signals coming from an in-plant process, programmable logic controller, motion controller, etc. to control speed. This results in significant labor and material cost reduction compared to other systems employing a separate drive and isolation card. The drive can be wired for normally open or normally closed contacts.

Choose the MM-PCM Series when there is a need for an isolated SCR drive with more features and better performance than the PCM20000 Series but less than that of the MM300 Series.

See page 50 for an in-depth comparison of the different models of drives.



MM03-115AC-PCM  
MM03-230AC-PCM  
MM10-115AC-PCM  
MM10-230AC-PCM

### MM-PCM DIMENSIONS

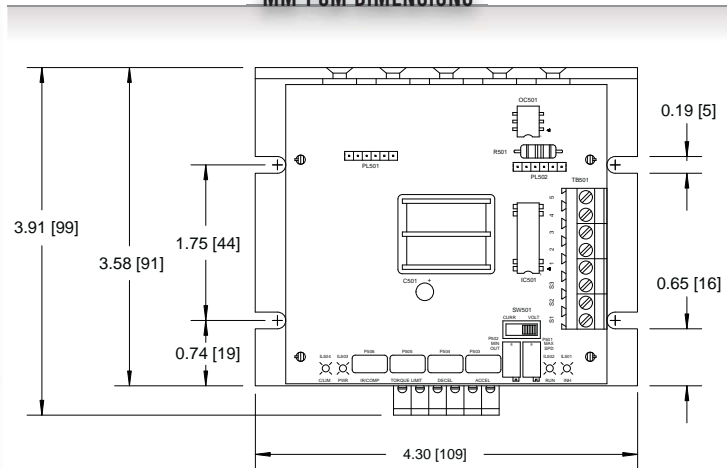



Height: 2.16 [55]

All dimensions in inches [millimeters]

Wiring diagrams of chassis of drives can be found on pages 60 and 68.

### FEATURES

- **MM footprint:** A compact industry standard footprint.
- **Isolated inputs:** Accepts floating or grounded signals of 0-10VDC or 4-20mA for controlling the speed of the motor. Burr-Brown isolation provides .01% linearity.
- **Speed range and regulation:** 2% regulation over 60:1 speed range.
- **User adjustable calibration pots:** IR compensation, min speed (12 turn), max speed (12 turn), torque limit, acceleration and deceleration.
- **Diagnostic LEDs:** LEDs for power, run, inhibit, and current limit status.
- **Stopping modes:** Choose N.O. or N.C. terminals to remotely decelerate to a stop by either closing or opening contacts.
- **Terminal blocks:** Allows users to easily wire controllers.
- **Additional features:** On-board line fusing.
- **Accessories:** Heatsink 223-0159, DLC600 digital closed loop controller.

Drive	Input Voltage (VAC)	Output Voltage (VDC)	Max Current (ADC)	HP Rating @ 90 VDC Output	HP Rating @ 180 VDC Output	Enclosure	Reversing	Isolation	Field Supply (VDC)	Form Factor	UL 	CUL 	CE 	Pre-Mounted Potentiometer
MM31701B	115	0-90	2	1/50 - 1/8	-	Chassis	-	-	-	1.37	-	-	-	-
MM31751B	115	0-90	2	1/50 - 1/8	-	Chassis	-	-	-	1.37	-	-	-	YES
MM31700B	115	0-90	3	1/8 - 1/4	-	Chassis	-	-	-	1.37	-	-	-	-
MM31750B	115	0-90	3	1/8 - 1/4	-	Chassis	-	-	-	1.37	-	-	-	YES
RD16U	115	0-90	3 <sup>1</sup>	1/8 - 1/4	-	Chassis	-	-	-	1.37	-	-	-	YES
SQ16U	115	0-90	3 <sup>1</sup>	1/50 - 1/8	-	Chassis	-	-	-	1.37	-	-	-	YES
SQ216U	230	0-90	3 <sup>1</sup>	1/50 - 1/8	-	Chassis	-	-	-	1.37	-	-	-	YES

<sup>1</sup> Peak rating of 3 Amps.

### MM3175xB DIMENSIONS

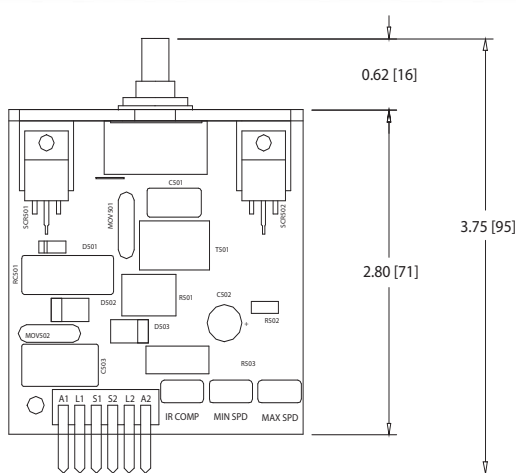

Height: 1.37 [55]  
All dimensions in inches [millimeters]

Dimensions of drives not shown above can be found on pages 55 and 56.  
Wiring diagrams of chassis drives can be found on pages 60 and 61.

### FEATURES

- **Small package:** Fits where other drives can't.
- **Low cost:** Designed for OEMs.
- **Speed range and regulation:** 3% regulation over 20:1 speed range.
- **User adjustable calibration pots:** IR compensation (MM31000 and SQ Series Only), min speed and max speed.
- **MM31000 removable terminal barrier:** Greatly reduces miswiring; easy installation.
- **Optional pre-mounted speed potentiometer:** Reduces wiring time and makes a compact package.
- **Built-in power switch:** The pot on the SQ and RD Series also acts as an AC power switch.

Minarik offers the MM31000, SQ, and RD Series of drives for cost sensitive variable-speed applications. These light-weight compact drives control DC brush-type motors ranging from 1/50 to 1/4 HP, without any additional components required. Reduced circuitry allows the cost to decrease significantly and also lends to a very compact package, ideal for original equipment manufacturers.

Several of the drives come with a speed pot already mounted on the drive. The SQ Series includes a knob and dial. A pre-wired removable terminal barrier on the MM31000 Series eliminates nearly half of the wiring required for other drives. Using full-wave rectification of the AC line input, these SCR drives provide moderate 20:1 speed range.

See page 50 for an in-depth comparison of the different models of drives.

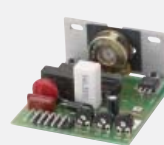

MM31750B  
MM31751B

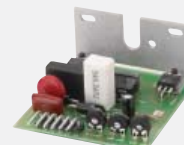

MM31700B  
MM31701B



RD16U



SQ16U  
SQ216U

Drive	Input Voltage (VAC)	Output Voltage (VDC)	Max Current (ADC)	HP Rating @ 90 VDC Output	HP Rating @ 180 VDC Output	Enclosure	Reversing *****	Isolation	Field Supply (VDC) *****	Form Factor	UL	CUL	CE
MC10	115/230	0-90 / 0-180	10	1/8 - 1	1/4 - 2	NEMA 4X	-	-	YES	1.37	YES	YES	-
MC10-PCM	115/230	0-90 / 0-180	10	1/8 - 1	1/4 - 2	NEMA 4X	-	0-10 VDC / 4-20 mA	YES	1.37	YES	YES	-
MC10-R	115/230	0-90 / 0-180	10	1/8 - 1	1/4 - 2	NEMA 4X	YES	-	YES	1.37	YES	YES	-

\*\*\*\* The field supply is rated at 1 Amp DC. A 50/100 VDC field is available with 115 VAC input, and a 100/200 VDC field is available with 230 VAC input.  
 \*\*\*\*\* Reversing models are designed for occasional reversing using the switch on the enclosure. See Regenerative drives in Section C for drives that can reverse on-the-fly or for drives with the ability to remote mount direction and braking switches.

The MC10 Series provides a reliable and economical solution for variable speed control of permanent magnet, or shunt wound brush DC motors from 1/8 to 2 horsepower.

Housed in a NEMA 4X enclosure, the dual voltage MC10 Series is ideal for washdown applications and provides protection from moisture, windblown dust and incidental contact.

Included are power and current limit LEDs, line fuses, inhibit pins for remote start/stop, and a speed adjust knob mounted on the front cover. In addition, the MC10 model includes an On/Off switch on the front cover; the MC10-R model- a Forward/Off/Reverse switch; and the MC10-PCM model- an On/Off switch and a Manual/Signal switch.

With excellent control and a plastic NEMA 4X enclosure, the MC10 Series is the perfect solution for many applications that require an enclosed drive.

See page 50 for an in-depth comparison of the different models of drives.



### MC10 SERIES DIMENSIONS

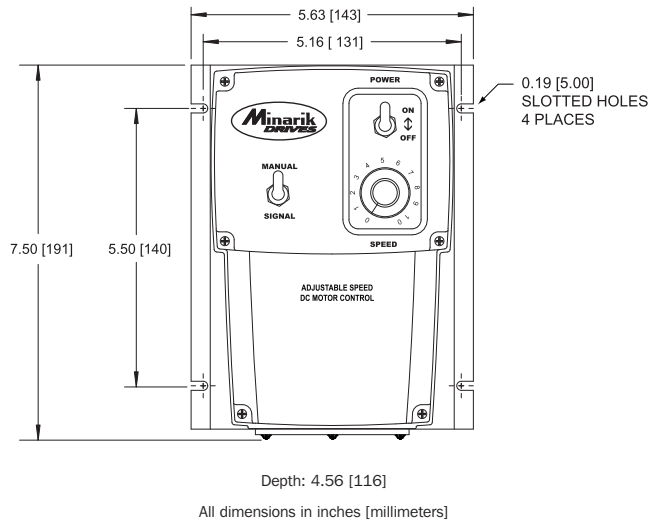

### FEATURES

- **NEMA 4X enclosure:** Plastic corrosion resistant weatherproof enclosure that protects against dirt and splashing water.
- **Speed range and regulation:** 1% regulation over 60:1 speed range.
- **User adjustable calibration pots:** IR compensation, minimum speed, maximum speed, torque limit, acceleration, and deceleration. The MC10-PCM unit also has signal min and signal max pots.
- **Diagnostic LEDs:** LEDs for power and current limit status.
- **Stopping modes:** Inhibit (N/O) for coasting to a stop.
- **Mounted operators:** Speed adjust knob located on front of case for easy operation. MC10-R includes direction switch and MC10-PCM includes signal/manual switch.
- **Screw terminal:** Quick and easy wire connections.
- **Analog input reference:** MC10-PCM can accept a 0-10VDC or 4-20mA with addition of a shunt resistor.
- **Accessories:** 201-0024 inhibit plug with 18" leads, DLC600 digital closed loop controller.

Drive	Input Voltage (VAC)	Output Voltage (VDC)	Max Current (ADC)	HP Rating @ 90/130 VDC Output	HP Rating @ 180 VDC Output	Enclosure	Reversing	Isolation	Field Supply (VDC)	Form Factor	UL	CUL	CE
MMXL02-D240AC	115/230	0-130 / 0-240	2	1/20 - 1/8	1/10 - 1/4	Chassis	*****	-	****	1.05	YES	-	YES
MMXL02-D240AC-PCM	115/230	0-130 / 0-240	2	1/20 - 1/8	1/10 - 1/4	Chassis	*****	0-5 VDC	****	1.05	YES	-	YES
MMXL05-D240AC	115/230	0-130 / 0-240	5	1/4 - 1/2	1/2 - 1	Chassis	*****	-	****	1.05	YES	-	YES
MMXL05-D240AC-PCM	115/230	0-130 / 0-240	5	1/4 - 1/2	1/2 - 1	Chassis	*****	0-5 VDC	****	1.05	YES	-	YES
MMXL10-D240AC	115/230	0-130 / 0-240	10*	1/2 - 1	1 - 2	Chassis	*****	-	****	1.05	YES	-	YES
MMXL10-D240AC-PCM	115/230	0-130 / 0-240	10*	1/2 - 1	1 - 2	Chassis	*****	0-5 VDC	****	1.05	YES	-	YES

\* Heatsink number 223-0159 must be used when the output is above 5 Amps.  
 \*\*\*\* A field supply is not available on the MMXL family of Drives. Minarik Drives recommends using the XL Series (pg 14).  
 \*\*\*\*\* See NRG-4Q Series (page 27) for a PWM Regenerative Drive that can reverse on-the-fly

### MMXL SERIES DIMENSIONS

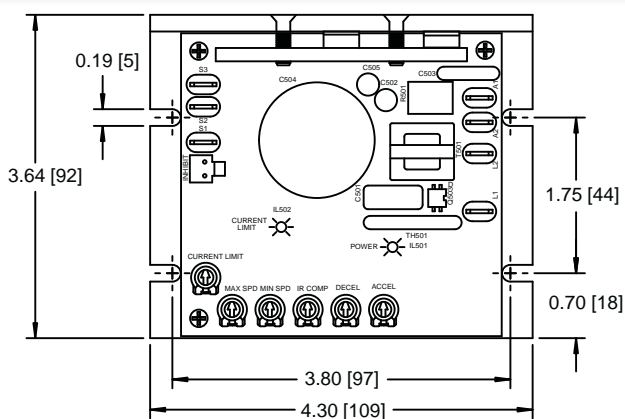

All dimensions in inches [millimeters]

Wiring diagrams of chassis drives can be found on pages 61 and 68.

### FEATURES

- **MM footprint:** A compact industry standard footprint.
- **Speed range and regulation:** 1% regulation over 100:1 speed range.
- **User adjustable calibration pots:** IR compensation, min speed, max speed, current limit, acceleration and deceleration.
- **Diagnostic LEDs:** LEDs for power and current limit status.
- **Stopping mode:** Inhibit (N/O) for coasting to a stop.
- **Spade terminals:** Easy to use, lower cost, and able to fit in a smaller package.
- **Auto-ranging power supply:** Accepts AC or DC input in the 115-230V range.
- **Options:** "-PCM" option adds isolation for the speed reference input and the inhibit pins.
- **Accessories:** Heatsink 223-0159. 201-0024 inhibit plug with 18" leads, DLC600 digital closed loop controller.

Minarik has always been a leader in providing low-cost PWM motor controls. With the MMXL Series, we have done it once again! We have taken a full-featured PWM drive and reduced it down to the standard MM footprint (4.30" x 3.64").



Not only did we keep all of the features of the larger XL Series, but we even added optical isolation to the speed circuit and the inhibit circuit in the "-PCM" model. This means that the speed can be controlled with any 0-5 VDC signal and many drives can be inhibited with a single contact closure. The auto ranging power supply allows the user to apply 115 or 230 VAC without adjusting any switches.

For cooler running motors and longer lasting brushes, Minarik Drives recommends upgrading SCR drives to PWM drives like the MMXL Series.

See page 50 for an in-depth comparison of the different models of drives.



MMXL02-D240AC & -PCM  
 MMXL05-D240AC & -PCM  
 MMXL10-D240AC & -PCM

Drive	Input Voltage (VAC)	Output Voltage (VDC)	Max Current (ADC)	HP Rating @ 90/130 VDC Output	HP Rating @ 180 VDC Output	Enclosure	Reversing	Isolation	Field Supply (VDC)	Form Factor	UL 	CUL 	CE 
XL3025A	115/230	0-130 / 0-240	3	1/20 - 1/4	1/8 - 1/3	Chassis	*****	***	YES	1.05	YES	-	YES
C4XL3025	115/230	0-130 / 0-240	3	1/20 - 1/4	1/8 - 1/3	NEMA 4X	*****	***	YES	1.05	-	-	YES
XL3050A	115/230	0-130 / 0-240	5	1/8 - 1/2	1/4 - 1	Chassis	*****	***	YES	1.05	YES	-	YES
XL3200A	115/230	0-130 / 0-240	10**	1/4 - 1	1/2 - 2	Chassis	*****	***	YES	1.05	YES	-	YES
C4XL3200A	115/230	0-130 / 0-240	10	1/4 - 1	1/2 - 2	NEMA 4X	*****	***	YES	1.05	-	-	YES
XL3300A	115/230	0-130 / 0-240	15	1/4 - 1 1/2	1/2 - 3	Chassis	*****	***	YES	1.05	-	-	YES

\*\* Heatsink number 223-0271 must be used when the output is above 5 Amps.  
 \*\*\* Built in isolation is not available on the XL family of drives. Minarik Drives recommends using the MMXL-PCM (pg 13), PCMPX (pg 15) or PCM4 (pg 45)  
 \*\*\*\* The field supply is rated at 1 Amp DC. A 50/100 VDC field is available with 115 VAC input, and a 100/200 VDC field is available with 230 VAC input.  
 \*\*\*\*\* See NRG-4Q Series (page 27) for a PWM Regenerative drive that can reverse on-the-fly.

Minarik's XL Series of pulse-width-modulated (PWM) variable-speed DC drives provide exceptional performance. They output nearly pure DC power to brush-type motors ranging from 1/20 to 3 HP. Drives accept 115 or 230 VAC input to output 0 to 130 or 240 VDC, respectively.

MOSFET power devices switch at a high frequency above the audible range, to provide fast circuit response and a constant 1.05 form factor over the entire 100:1 speed range. Highly-efficient XL drives provide cool, quiet motor operation with extended brush life and low maintenance. For convenience, the drives have a cage-clamp terminal block to make wiring easy. The XL3300A can jog motors from 0 -120% of rated speed with a separate trimmer pot.

See page 50 for an in-depth comparison of the different models of drives.



C4XL3025



XL3025A  
 XL3050A  
 XL3200A



XL3300A



C4XL3200A

**XL3025A / XL3050A / XL3200A DIMENSIONS**

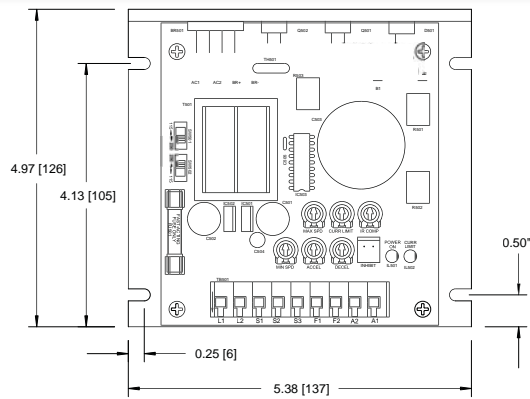

HEIGHT	
XL3025A	2.25 [57]
XL3050A	3.00 [76]
XL3200A	3.75 [95]

All dimensions in inches [millimeters]

Dimensions of drives not shown above can be found on page 56.  
 Wiring diagrams of chassis drives can be found on page 61 and 68.

**FEATURES**

- **Speed range and regulation:** 1% regulation over 100:1 speed range.
- **User adjustable calibration pots:** IR compensation, min speed, max speed, current limit, acceleration, deceleration and jog (XL3300A and C4XL3200A only).
- **Diagnostic LEDs:** LEDs for power and current limit status.
- **Stopping mode:** Inhibit (N/O) for coasting to a stop on all models.
- **Cage clamp terminal block:** Quick and easy wire terminations reduce installation time!
- **Additional features:** Dual voltage AC input, DC field supply, on board line fuse, and jog mode on C4XL3200A and XL3300A.
- **Accessories:** Heatsink 223-0271. 201-0024 inhibit plug with 18" leads, DLC600 digital closed loop controller.



Drive	Input Voltage (VAC)	Output Voltage (VDC)	Max Current (ADC)	HP Rating @ 90/130 VDC Output	HP Rating @ 180 VDC Output	Enclosure	Reversing	Isolation	Field Supply (VDC)	Form Factor	UL	CUL	CE
C1XP01-115AC-A	115	0-130	1	1/100 - 1/10	-	NEMA 1	-	-	-	1.05	YES	-	YES
XP02-115AC	115	0-130	2	1/20 - 1/8	-	Chassis	*****	-	****	1.05	YES	-	-
XP02-115AC-Q	115	0-130	2	1/20 - 1/8	-	Chassis	*****	-	****	1.05	-	-	-
PCMPX02-115AC	115	0-130	2	1/20 - 1/8	-	Chassis	*****	0-10 VDC	-	1.05	YES	-	-
C1XP03-115AC-A	115	0-130	3	1/10 - 1/4	-	NEMA 1	-	-	-	1.05	YES	-	YES
XP05-115AC	115	0-130	5	1/4 - 1/2	-	Chassis	*****	-	****	1.05	YES	-	-
PCMPX05-115AC	115	0-130	5	1/4 - 1/2	-	Chassis	*****	0-10 VDC	-	1.05	YES	-	-
XP10-115AC	115	0-130	10*	1/2 - 1	-	Chassis	*****	-	****	1.05	YES	-	-
PCMPX10-115AC	115	0-130	10*	1/2 - 1	-	Chassis	*****	0-10 VDC	-	1.05	YES	-	-

\* Heatsink number 223-0159 must be used when the output is above 5 Amps.  
 \*\*\*\*\* A field supply is not available on the XP family of Drives. Minarik Drives recommends using the XL Series (pg 14).  
 \*\*\*\*\* See NRG-4Q Series (page 27) for a PWM Regenerative drive that can reverse on-the-fly.

**XPxx-115AC DIMENSIONS**

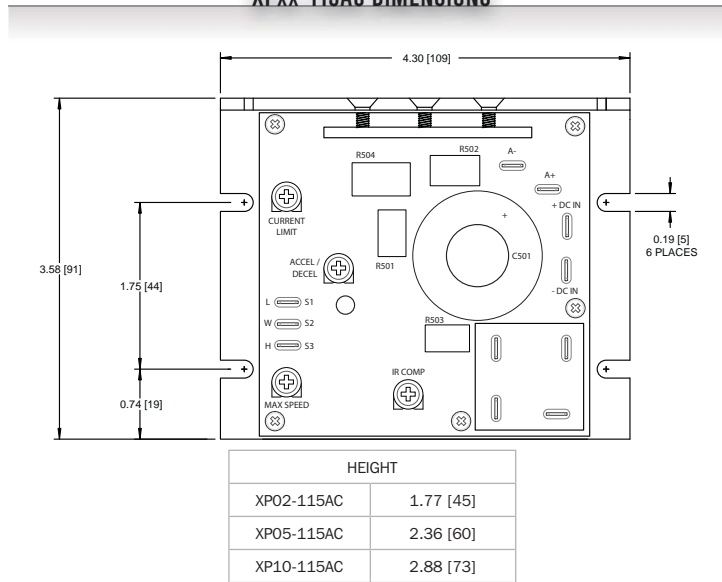

All dimensions in inches [millimeters]  
 Dimensions of drives not shown above can be found on page 56 and 57.  
 Wiring diagrams of chassis drives can be found on pages 61, 62 and 68.

**FEATURES**

- **MM footprint:** Chassis drives have an industry standard footprint.
- **Low cost:** Designed for OEM applications.
- **Speed range and regulation:** 1% regulation over 80:1 speed range.
- **User adjustable calibration pots:** IR compensation, max speed, min speed (PCMPX and C1XP only), current limit, acceleration/deceleration (XP drives only), and signal adjust (PCMPX only).
- **Spade terminals:** Easy to use, lower cost, and able to fit in a smaller package.
- **Accepts AC or DC input:** Can accept 100-160VDC input voltage or 70-130VAC.
- **Options:** "-Q" option on the XP02-115AC adds a terminal block, on-board fusing, inhibit, and replaces the accel/decel trimpot with a min speed trimpot.
- **Accessories:** Heatsink 223-0159, DLC600 digital closed loop controller.

Specifically designed for the original equipment manufacture (OEM), the XP Series of DC motor speed drives provide high performance at a low cost. These drives are well suited for MMXL or XL drive applications who do not need all of their features. These PWM drives result in a smooth, quiet, cool and low maintenance motor operation.

The C1XP Series is enclosed in a compact NEMA 1 enclosure. The PCMPX Series includes isolation so the drive can follow a remote 0-10VDC from a PLC.

Choose the XP Series for the best low cost PWM drive on the market.

See page 50 for an in-depth comparison of the different models of drives.



C1XP01-115AC-A  
 C1XP03-115AC-A



XP02-115AC-Q



PCMPX02-115AC  
 PCMPX05-115AC  
 PCMPX10-115AC



XP05-115AC  
 XP10-115AC

## Isolated PWM DC Chassis

B

Drive	Input Voltage (VAC)	Output Voltage (VDC)	Max Current (ADC)	HP Rating @ 12 VDC Output	HP Rating @ 24 VDC Output	Enclosure	Reversing	Isolation	Field Supply (VDC)	Form Factor	UL	CUL	CE
HTL05-D-4Q	115/230	0-12 / 0-24	5	*****	*****	Chassis	YES	0 - 5 / 0 - 10 VDC	-	1.05	YES	YES	-

\*\*\*\*\* Minarik Drives recommends sizing the motor and drive combination based off the motor current, not motor HP.

The HTL Series is an all in one solution to control a 12 or 24 VDC motor when only 115 or 230 VAC is available. The HTL05-D-4Q design combines an AC to DC switching power supply with a PWM DC drive, allowing exceptional control of a low voltage motor with a high voltage supply.

The HTL Series allows for braking and reversing on the fly with a simple input to the drive. The drive has built-in isolation so interfacing to PLC is simplified. This drive also works great for **limit switch** and **actuator** applications because it has independent inhibits. Add an “-L” suffix for a version of the HTL Series that will work with linear actuators containing pot feedback for positioning applications.

The microprocessor on this drive allows the HTL Series to be extremely flexible for OEM applications. Custom applications or routines can be programmed into the HTL Series to meet your OEM needs. The drive contains LEDs for power and current limit status along with calibration trimpots that can be customized at our factory for an OEM application.

Choose the HTL Series for applications utilizing 12 or 24 VDC motors that need to be powered from 115 or 230 VAC.

See page 52 for an in-depth comparison of the different models of drives.



HTL05-D-4Q

### HTL05-D-4Q DIMENSIONS

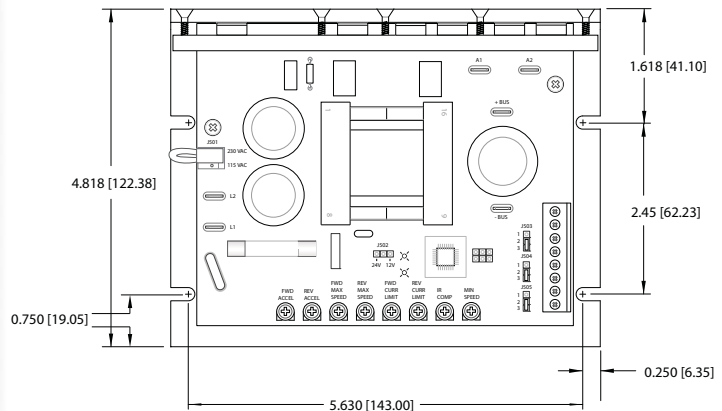



Height: 2.00 [51]

All dimensions in inches [millimeters]

Wiring diagrams of chassis drives can be found on page 62.

### FEATURES

- **True low voltage output:** Allows use of 115 or 230 VAC supply voltage on 12 or 24 VDC motors.
- **4Q reversing:** Regenerative / 4 Quadrant drives have the ability to perform quick, contactorless, braking and/or reversing on-the-fly!
- **Isolation:** Easy interface to a PLC (0-5 or 0-10 VDC).
- **User adjustable calibration pots:** Trimpot adjustments for forward acceleration, reverse acceleration, forward max speed, reverse max speed, forward current limit, reverse current limit, IR comp, and min speed.
- **Diagnostic LEDs:** LEDs for power and current limit status.
- **Stopping modes:** Forward inhibit and reverse inhibit can be set for N/O or N/C to brake to a stop.
- **Spade and screw terminals:** Spade terminals for power connections and screw terminals for logic connections.
- **All in one package:** Switching power supply and DC drive in one package.
- **Options:** “-L” option allows the drive to work with actuators containing a linear pot.

Drive	Input Voltage (VDC)	Output Voltage (VDC) *****	1 Min. Peak Current Amps (DC)	Cont. Current Amps DC	HP Rating @ Low Voltage	HP Rating @ High Voltage	Enclosure	Reversing	Field Supply VDC	Form Factor	UL 	CUL 	CE 
DC1.5-12	8 - 16	0 - 12	1.5	1	*****	-	Chassis	*****	-	1.01	-	-	-
DC1.5-24	16-32	0 - 24	1.5	1	-	*****	Chassis	*****	-	1.01	-	-	-

\*\*\*\*\* See DC30-4Q Series (page 20) for a PWM low voltage regenerative drive that can reverse on-the-fly.  
 \*\*\*\*\* Minarik Drives recommends sizing the motor and drive combination based off the motor current, not motor HP.  
 \*\*\*\*\* The Maximum output voltage is equal to: Input Voltage - 1 VDC. Reverse polarity diode protection can be removed so maximum output voltage equals the input voltage.

DC1.5 SERIES DIMENSIONS

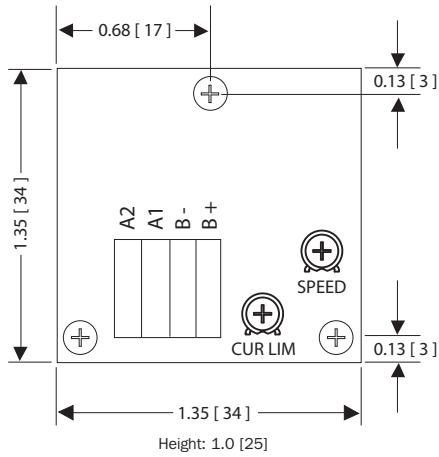

All dimensions in inches [millimeters]

Wiring diagrams of chassis drives can be found on page 62.

FEATURES

- **Compact footprint:** Fits in places where you never thought a drive could. Custom round PCB's are available to mount directly on the back of a motor.
- **Low voltage motor operation:** Designed for 12 and 24 VDC motors.
- **User adjustable calibration pots:** Speed and Current Limit.
- **Current Limit:** Limits the torque so gears are not stripped in an overload situation.
- **Cage clamp terminal block:** Quick and easy wire terminations reduce installation time.
- **Microprocessor based design:** Allows quick turnaround for custom units.
- **Reverse polarity protection:** The drive is not damaged when connected to the battery or power supply backwards.
- **Ideal for battery powered equipment:** Maintains both set and/or variable speed control even as battery voltage declines. Extends total running time of equipment.

Minarik Drives' new DC1.5 Family is changing the way OEMs look at small low voltage DC motor and drive applications. This incredibly small microprocessor based drive provides both speed control and current limit at a low cost.

OEMs are implementing these drives in applications that did not traditionally use a drive. Many small low voltage DC motors are run directly off a power supply or battery. This method does not provide efficient speed control or reasonable current limit, two critical items that are achieved by using a DC1.5 Family of drives. The drive pays for itself when it protects the motor just once from burning up because of a jam. IR comp can be customized for OEMs to allow for much better speed control and regulation compared to systems not using a drive.

The drive contains Speed and Current Limit trim pots on the board. These units can also control speed with a remote pot by ordering the drive with the on-board speed pot removed and replaced with a header. A diode is included on the drive to protect against damage from hooking the drive up to a battery or power supply backwards.

The small size and low cost of the DC1.5 Family make it a great choice for OEMs using small geared and non-geared DC motors. Review the HTL Series (page 16) for applications that require a 115 or 230 VAC input.

See page 51 for an in-depth comparison of the different models of drives.



DC1.5

Drive	Input Voltage	Output Voltage	1 Min. Peak Current Amps (DC)	Cont. Current Amps (DC)	HP Rating @ Low Voltage	HP Rating @ High Voltage	Enclosure	Reversing	Field Supply (VDC)	Form Factor	UL	CUL	CE
LV01-24AC	8 - 24 VAC	0 - 24 VDC	-	1		*****	Chassis	-	-	1.05	YES	YES	YES
LV02-24AC	8 - 24 VAC	0 - 24 VDC	-	2		*****	Chassis	-	-	1.05	YES	YES	YES
LV02-24DC	10 - 36 VDC	0 - 24 VDC	-	2		*****	Chassis	-	-	1.01	YES	YES	YES

\*\*\*\*\* Minarik Drives recommends sizing the motor and drive combination based off the motor current, not motor HP

Minarik's LV Family of variable speed drives provide exceptional performance for your fractional horsepower, low voltage DC motor (12 and 24 VDC). These compact, low cost drives are designed to provide 1% speed regulation throughout a 100:1 speed range.

Packaged in a compact footprint, these user friendly drives are available with AC or DC input voltage. The auto ranging unipolar power supply allows standard LV drives to accept inputs from any AC voltage source ranging from 8 to 24VAC, or DC voltage between 10 to 36 VDC.

The PWM circuitry in the LV drives result in a 1.05 form factor over the entire speed range when an AC power input is provided. With a DC input these drives have an almost perfect DC form factor of 1.01.

The LV Family is ideal for cost sensitive variable speed applications requiring outstanding performance, and cooler, quieter motor operation from low voltage DC motors.

Review the HTL Series (pg. 16) for applications that require a 115 VAC or 230 VAC input to run a low voltage motor.

See page 51 for an in-depth comparison of the different models of drives.



LV01-24AC  
LV02-24AC  
LV02-24DC

### LV SERIES DIMENSIONS

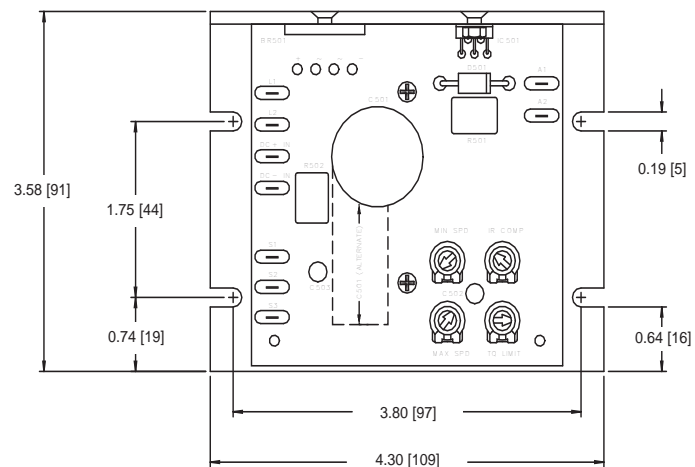

Height: 1.40 [36]

All dimensions in inches [millimeters]

Wiring diagrams of chassis drives can be found on page 62 and 68.

### FEATURES

- **MM footprint:** A compact industry standard footprint.
- **Low voltage motor operation:** Designed for 12 and 24 VDC motors.
- **Speed range and regulation:** 1% speed regulation over 100:1 speed range.
- **User adjustable calibration pots:** IR compensation, min speed, max speed and torque.
- **Spade terminals:** Easy to use, lower cost and able to fit in a smaller package.
- **16kHz switching frequency:** A high switching frequency means a quiet motor!
- **Ideal for battery powered equipment:** Maintains both set and /or variable speed even as battery voltage declines. Extends total running time of equipment.
- **Additional features:** AC or DC input choices and near unity form factor throughout the speed range.

Drive	Input Voltage (VDC)	Output Voltage (VDC)	1 Min. Peak Current Amps (DC)	Cont. Current (ADC)	HP Rating @ Low Voltage	HP Rating @ High Voltage	Enclosure	Reversing	Field Supply (VDC)	Form Factor	UL 	CUL 	CE 
DC16-12/24	10 - 32	Up to 95% of Input	-	16	1/20 - 1/5	1/10 - 2/5	Chassis	*****	-	1.01	YES	YES	-
DC60-12/24	10 - 32	Up to 95% of Input	-	60	1/8 - 3/4	1/4 - 1 1/2	Chassis	*****	-	1.01	YES	YES	-
DC60-36/48	32 - 50	Up to 95% of Input	-	60	1/2 - 2 1/4	1/2 - 3	Chassis	*****	-	1.01	YES	YES	-

\*\*\*\*\* Reversing is not built into the DC-DC Series. Minarik Drives recommends using the DC30-4Q (page 20), DC250 or DC240 Family (pg 21).

### DC16-12/24 DIMENSIONS

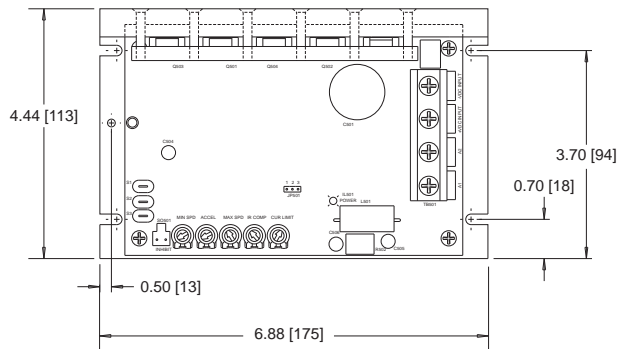

Height: 2.20 [58]

All dimensions in inches [millimeters]

Dimensions of drives not shown above can be found on page 57.

Wiring diagrams of chassis drives can be found on pages 63 and 68.

### FEATURES

- **Low voltage motor operation:** Designed for 12, 24, 36 and 48 VDC motors.
- **Speed range and regulation:** 1% regulation over 80:1 speed range.
- **User adjustable calibration pots:** IR compensation, max speed, min speed, acceleration and current limit.
- **Diagnostic LEDs:** Power.
- **Stopping modes:** Inhibit (N/O) for coasting to a stop.
- **Spade terminals and screw terminal block:** Quick and easy connections.
- **DC input voltage:** Accepts DC input and outputs DC voltage up to 95% of the input with near perfect form factor.
- **One drive for two motor voltages:** On board jumper to select 12 or 24VDC motor (36 or 48VDC on some models).
- **Ideal for battery powered equipment:** Maintains both set and/or variable speed control even as battery voltage declines. Extends total running time of equipment.
- **Accessories:** 201-0024 inhibit plug with 18" leads.

The DC-DC Family are DC in / DC out PWM chassis drives. These feature rich drives include inhibit for remote starting and stopping, a power LED, and trimmer pot adjustments for minimum speed, maximum speed, acceleration, IR comp, and current limit. All trimmer pots are non-interactive making calibration quick and easy.

The DC-DC Family is available in three sizes: 16A and 60A units for 12 or 24 VDC motors and a 60A unit for 36 or 48 VDC motors. Perfect for use with battery-powered equipment, the DC-DC Family is able to maintain variable speed control as the battery discharges. This results in an increase in running time of battery-operated equipment. The DC-DC Family is ideal for many types of portable equipment.

The UL approved DC-DC Family comes with an extruded chassis for better heat sink transfer to the heatsink, more bus capacitance to handle ripple currents, and an oversized terminal block that can handle high currents. With 1% speed regulation over an 80:1 speed range, the DC-DC Family is the perfect solution for low voltage, DC-to-DC applications!

See page 51 for an in-depth comparison of the different models of drives.



DC16-12/24



DC60-12/24  
DC60-36/48

Drive	Input Voltage (VDC)	Output Voltage (VDC)	1 Min. Peak Current Amps (DC)	Cont. Current Amps (DC)	HP Rating @ Low Voltage	HP Rating @ High Voltage	Enclosure	Rev-ersing	Field Supply (VDC)	Form Factor	UL	CUL	CE
DC30-12/24-4Q	8- 32	Up to 95% of Input	30	15	1/20 - 1/5	1/10 - 2/5	Chassis	YES	-	1.01	-	-	-

The DC30-12/24-4Q is Minarik Drives' latest drive in our expanding low voltage DC product line. The DC30 is a PWM regenerative (four quadrant) drive, meaning it can reverse and/or brake on the fly without bulky contactors and resistors. The drives put regenerated power from the motor back to the battery supply, thus extending battery life.

These drives have calibration capabilities of Motor Current Limit, Regen Current Limit, Accel, Decel, IR Comp, Min Speed, Forward Max Speed, and Reverse Max Speed. Watch for the new hand held programming tool that will soon be released to calibrate the drive through the programmer instead of using the on-board trim pots.

The DC30 is a microprocessor based drive like all of our new low voltage controls. Our microprocessor based drives are very OEM friendly. Many of our customers have eliminated the need for a PLC and/or sensors in their system by utilizing the flexible I/O of the DC30. Minarik Drives caters to OEMs who need something tweaked or modified, unlike the other major low voltage drive manufacturers. Contact Minarik Drives with your custom needs and ideas.

See page 51 for an in-depth comparison of the different models of drives.

Note that the picture below is of our OEM version without the daughter board or adjustment trim pots.



DC30-12/24-4Q

### DC30-12/24-4Q DIMENSIONS

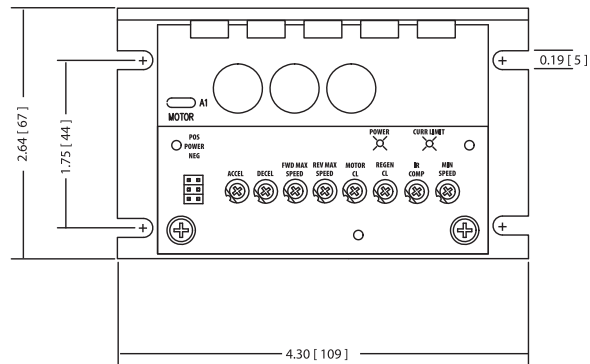

Height: 1.50 [38]

All dimensions in inches [millimeters]

Wiring diagrams of chassis drives can be found on page 63.

### FEATURES

- **Low voltage motor operation:** Designed for 12 or 24 VDC motors.
- **4Q reversing:** Regenerative / 4 Quadrant drives have the ability to perform quick, contactorless, braking and/or reversing on-the-fly!
- **User adjustable calibration:** Motor Current Limit, Regen Current Limit, Accel, Decel, IR Comp, Min Speed, Forward Max Speed, and Reverse Max Speed.
- **Diagnostic LEDs:** Power, current limit, over voltage, under voltage, and overheat foldback.
- **Stopping modes:** Brake or coast to a stop.
- **Microprocessor based:** Allows for special calibration ranges or custom I/O for OEMs
- **High efficiency:** Outputs up to 95% of the input voltage.
- **Ideal for battery powered equipment:** Maintains both set and/or variable speed even as battery voltage declines. Extends total running time of equipment.

Drive	Input Voltage (VDC)	Output Voltage (VDC)	1 Min. Peak Current (ADC)	Cont. Current (ADC)	HP Rating @ Low Voltage	HP Rating @ High Voltage	Enclosure	Reversing	Field Supply (VDC)	Form Factor	UL	CUL	CE
DC250-12/24-4Q	10 - 32	Up to 100% of Input	250	120*	1/4 - 1 1/2	1/2 - 3	Chassis	YES	-	1.01	-	-	-
DC240-36/48-4Q	20 - 62	Up to 100% of Input	240	100**	3/4 - 3 1/2	1 - 5	Chassis	YES	-	1.01	-	-	-

\* Derate by 15% when mounted horizontally.  
\*\* Derate by 20% when mounted horizontally.

### DC250 and DC240 SERIES DIMENSIONS

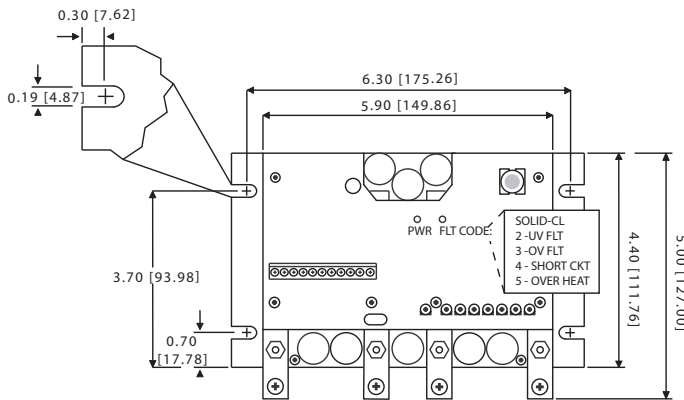

Height: 2.50 [64]

All dimensions in inches [millimeters]

Wiring diagrams of chassis drives can be found on page 63.

### FEATURES

- **Low voltage motor operation:** Designed for 12, 24, 36, and 48 VDC motors.
- **4Q reversing:** Regenerative / 4 Quadrant drives have the ability to perform quick, contactorless, braking and/or reversing on-the-fly!
- **High continuous current:** Up to 120 Amps continuous, robust bus bars used to handle the current. Adding fans for sufficient airflow can increase the current rating by more than 25%.
- **User adjustable calibration pots:** Trimpot adjustments for IR compensation, fwd max speed, rev max speed, min speed, accel, decel, motoring current limit, and regenerative current limit.
- **Diagnostic LEDs:** Power, current limit, under voltage, over voltage, overheat and short circuit.
- **Stopping modes:** Brake (N/O) or coast (N/O) to a stop.
- **High efficiency:** Outputs up to 100% of the input.
- **Short circuit protection:** Unit protects itself against a shorted motor.
- **Sleep mode:** Drive enters sleep mode when disabled to extend battery life.
- **Temperature sensor:** Current limit automatically reduced if controller heats up.
- **Ideal for battery powered equipment:** Maintains both set and/or variable speed even as battery voltage declines. Extends total running time of equipment

The DC-4Q Family of drives are DC in / DC out PWM chassis drives capable of four quadrant reversing and braking. This Family of drives is ideal for portable battery powered equipment. The DC-4Q has a sleep mode for extended battery life while not in use. The four quadrant capability allows simple connections for fast reversing and/or braking without the need for bulky contactors or braking resistors. While the standard DC-4Q Family is meant for DC permanent magnet motors, a similar DCS-R Family is available for series wound motors.

The DC-4Q Family of drives have adjustments for IR Compensation, Motoring Current Limit, Regenerative Current Limit, Forward Max Speed, Reverse Max Speed, Min Speed, Deceleration and Acceleration Time. These drives are microprocessor based meaning these ranges can be reprogrammed to meet any custom needs. The DC-4Q Family also has Power and Fault LEDs, including current limit, under voltage, over voltage, overheat, and short circuit.

The DC-4Q Family is available in two models, one for 12-24 VDC systems, the other is designed for 36-48 VDC systems. For simplicity and safety, no jumpers or switches are required for selecting voltages.

See page 51 for an in-depth comparison of the different models of drives.



DC250-12/24-4Q  
DC240-36/48-4Q

Drive	Input Voltage (VDC)	Output Voltage (VDC)	2 Min. Peak Current (ADC)	Cont. Current (ADC)	HP Rating @ 36 VDC Output	HP Rating @ 48 VDC Output	Enclosure	Reversing	Field Supply (VDC) ****	Form Factor	UL	CUL	CE
DC500N-4Q-36/48	36-48	Up to 100% of input	500	200	1 1/2 - 7 1/2	2 - 10	NEMA 1	YES	YES	1.01	-	-	-

\*\*\*\* The field supply is rated at 50 Amps for 2 minutes or 15 Amps for continuous operation.

The DC500N PWM DC drive was developed and designed for battery operated electric vehicles with **separately excited** DC motors but can be configured to control series wound motors for OEMs. The DC500N replaces the original DC500. The DC500N has a new and improved water tight connector.

DC500N has many safety features for integration into electric vehicles including runaway and rollaway protection, battery under-voltage control, and protection from overheating.

The DC500N drive detects when battery voltage drops too low, and will gradually boost the field current to compensate. This provides torque to get back to the charging station.

The DC500N drive heatsink has a temperature sensor that at 60°C triggers a warning signal along with gradual automatic field current boosting and armature current cutbacks to help keep the drive below the shut down temperature of 85°C.

Configurable safety parameters, such as speed limit, throttle voltage range, current limit and braking amount are set via any terminal program on a Windows based PC. Connection to the DC500N drive is via a standard DB9 female-male serial cable.

Packed with all the necessary features, the DC500N drive is the perfect solution for high-performance industrial or recreational battery operated vehicle motor control.

See page 51 for an in-depth comparison of the different models of drives.



DC500N-4Q-36/48

**DC500N-4Q-36/48 DIMENSIONS**

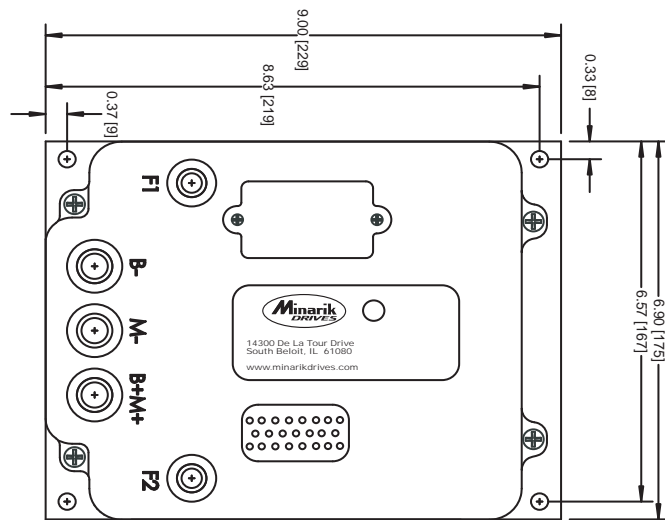

Depth: 4.75 [121]

All dimensions in inches [millimeters]

Wiring diagrams of chassis drives can be found on page 64.

**FEATURES**

- **Designed for battery-powered vehicles:** Industrial or recreational.
- **PC programmable parameters:** Speed limit, current limit, throttle high and low voltages, braking amount.
- **Diagnostic:** Fault detection with flashing LED signalization.
- **Safety features:** Protection from high-speed runaway, rollaway, overheating and main contactor arcing. Under-voltage control, low power direction, switching, and back-up alarm signals.
- **User outputs:** Hour meter signal for time-in-use measuring. Isolated frequency output for speedometer.
- **User inputs:** Engage "hill" mode for more torque and less speed. Cruise Control (on special models only).
- **Stopping Modes:** Regenerative braking. Regen energy stored to extend battery charge range.
- **Plug in connector:** Easy wire up. Locking feature keeps connection secure.



Drive	Input Voltage (VAC)	Output Voltage (VDC)	Max Current (ADC)	HP Rating @ 90 VDC Output	HP Rating @ 180 VDC Output	Enclosure	Reversing	Isolation ***	Field Supply (VDC) ****	Form Factor	UL	CUL	CE
RG510UA	115/230	0-90 / 0-180	3	1/20 - 1/8	1/10 - 1/4	Chassis	YES	-	YES	1.37	YES	YES	YES
RG510UA-PCM	115/230	0-90 / 0-180	3	1/20 - 1/8	1/10 - 1/4	Chassis	YES	YES	YES	1.37	YES	YES	YES
RG510A	115/230	0-90 / 0-180	3	1/20 - 1/8	1/10 - 1/4	NEMA 4X	YES	-	YES	1.37	YES	YES	YES
RG500UA	115/230	0-90 / 0-180	10**	1/4 - 1	1/2 - 2	Chassis	YES	-	YES	1.37	YES	YES	YES
RG500UA-PCM	115/230	0-90 / 0-180	10**	1/4 - 1	1/2 - 2	Chassis	YES	YES	YES	1.37	YES	YES	YES
RG500A	115/230	0-90 / 0-180	10	1/4 - 1	1/2 - 2	NEMA 4X	YES	-	YES	1.37	YES	YES	YES

\*\* Heatsink number 223-0235 must be used when the output is above 7 Amps.  
 \*\*\* Isolated models can accept 0-10 VDC, 0 - ±10 VDC, or 4-20 mA signals.  
 \*\*\*\* The field supply is rated at 1 Amp DC. A 50/100 VDC field is available with 115 VAC input, and a 100/200 VDC field is available with 230 VAC input.

**RG5x0UA DIMENSIONS**

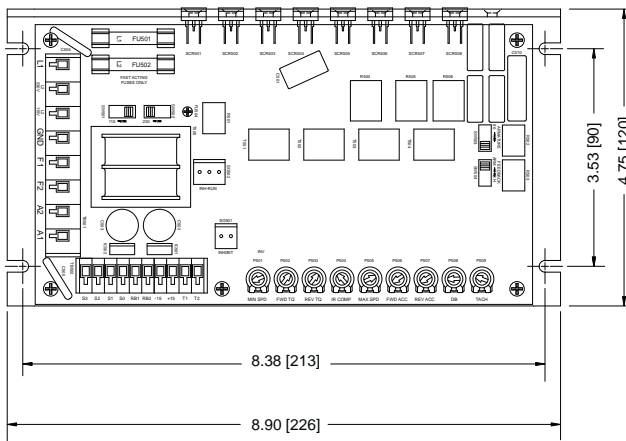

Height: 1.85 [47]

All dimensions in inches [millimeters]

Dimensions of drives not shown above can be found on page 57.  
 Wiring diagrams of chassis drives can be found on pages 65 and 69.

**FEATURES**

- **4Q reversing:** Regenerative / 4 quadrant drives have the ability to perform quick, contactorless, reversing on-the-fly!
- **NEMA 4X enclosure:** RG510A and RG500A come in a rugged metal corrosion resistant, weatherproof enclosure that protects against dirt and splashing water.
- **Speed range and regulation:** 1% regulation over 50:1 speed range. 0.1% regulation over 60:1 speed range with the addition of a tachometer for feedback.
- **User adjustable calibration pots:** IR compensation, forward torque, reverse torque, tachometer, min speed, max speed, forward acceleration, reverse acceleration and deadband.
- **Stopping modes:** Inhibit (N/O) to immediately brake to a stop. RB1 and RB2 (N/O) to decelerate to a stop.
- **Cage clamp terminal block:** Quick and easy wire terminations.
- **On board fusing:** No need to add external fusing for protection of your motor or drive.
- **Options and Accessories:** Heatsink 223-0235. "-PCM" option adds Burr Brown isolation, 201-0024 inhibit plug with 18" leads, and 200-0386 limit switch logic board, and DLC600 digital closed loop controller.

Minarik's RG500 Series consists of full-wave, four-quadrant regenerative SCR drives to provide smooth motoring and braking torque for brush-type DC motors. The RG500 Series is a proven design with many years of success in the industrial marketplace.

Regenerative drives such as the RG500 Series are great for applications with overhauling loads, rapid deceleration, basic positioning, and high duty cycle reversing and braking. The RG500 Series includes standard chassis, isolated chassis, and enclosed NEMA 4X models. The RG500 Series drive used with a 200-0386A limit switch logic board provides a variety of routines for limit switch applications.

Choose the RG500 Series when the application calls for a well proven and reliable regenerative drive. The RG500 Series survives in environments that others can't.

See page 52 for an in-depth comparison of the different models of drives.



Drive	Input Voltage (VAC)	Output Voltage (VDC)	Max Current (ADC)	HP Rating @ 90 VDC Output	HP Rating @ 180 VDC Output	Enclosure	Reversing	Isolation	Field Supply (VDC) ****	Form Factor	UL	CUL	CE
RG511A	115/230	0-90 / 0-180	3	1/20 - 1/8	1/10 - 1/4	NEMA 4X	YES	-	YES	1.37	YES	YES	YES
RG501A	115/230	0-90 / 0-180	10	1/4 - 1	1/2 - 2	NEMA 4X	YES	-	YES	1.37	YES	YES	-

\*\*\*\* The field supply is rated at 1 Amp DC. A 50/100 VDC field is available with 115 VAC input, and a 100/200 VDC field is available with 230 VAC input.

The RG501A/RG511A are dual voltage full-featured regen drives in a rugged enclosure. These high performance drives maintain motor speed with automatic motoring and braking torque, while allowing high-duty cycle reversing and braking, great for limit switch applications.

The RG501A/RG511A have conveniently mounted operators. Included are a power on/off switch and separate forward and reverse speed potentiometers so independent speeds for each direction are easily set. Controlling the motor is easy too, by pressing a button on the membrane panel for stop, run, reverse, or jog (jog speed is adjustable). The user can also wire in remote pushbuttons in conjunction with the on-board buttons.

Included and wired into the RG501A/RG511A package is our limit switch logic board (200-0386A). This mini-PLC can operate in one of nine modes between limit switches including continuous cycling, single cycle, dwell and more—including adjustable stop and dwell times!

See page 52 for an in-depth comparison of the different models of drives.



RG501A  
RG511A

RG5x1A DIMENSIONS

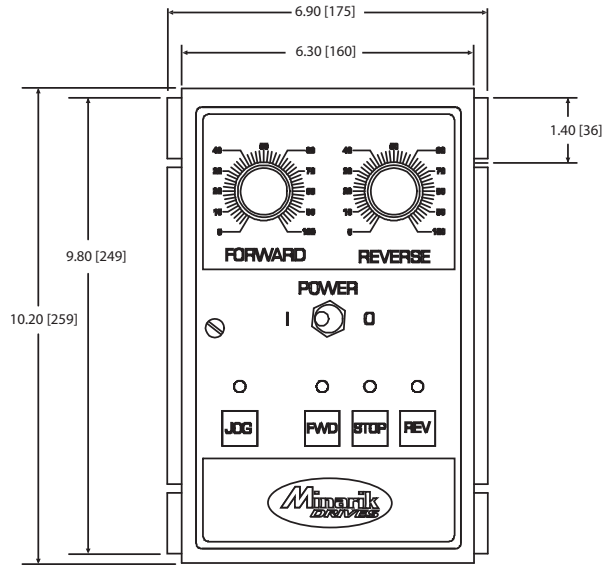

Depth: 5.50 [140]  
All dimensions in inches [millimeters]

FEATURES

- **NEMA 4X enclosure:** Rugged metal corrosion resistant, weatherproof enclosure, that protects against dirt and splashing water.
- **4Q reversing:** Regenerative / 4 quadrant drives have the ability to perform quick, contactorless, reversing on-the-fly!
- **Speed range and regulation:** 1% regulation over 50:1 speed range. 0.1% regulation over 60:1 speed range with the addition of a tachometer for feedback.
- **User adjustable calibration pots:** IR compensation, forward torque, reverse torque, tachometer, min speed, max speed, forward acceleration, reverse acceleration, deadband, forward jog, reverse jog, and dwell time (for limit switch mode).
- **Diagnostic LEDs:** LEDs for jog, forward, reverse, and stop.
- **Stopping modes:** User can regeneratively brake to a stop with a local or remote push button.
- **Cage clamp and screw terminal block:** Quick, secure and easy wire terminations.
- **On board fusing:** No need to add external fusing for protection of your drive.

Drive	Input Voltage (VAC)	Output Voltage (VDC)	Max Current (ADC)	HP Rating @ 90 VDC Output	HP Rating @ 180 VDC Output	Enclosure	Reversing	Isolation ***	Field Supply (VDC)	Form Factor	UL	CUL	CE
RG61U	115/230	0-90 / 0-180	1.5	1/20 - 1/8	1/10 - 1/4	Chassis	YES	-	****	1.37	YES	YES	-
RG61U-PCM	115/230	0-90 / 0-180	1.5	1/20 - 1/8	1/10 - 1/4	Chassis	YES	YES	****	1.37	YES	YES	-
RG60U	115/230	0-90 / 0-180	10*	1/8 - 1	1/4 - 2	Chassis	YES	-	****	1.37	YES	YES	-
RG60U-PCM	115/230	0-90 / 0-180	10*	1/8 - 1	1/4 - 2	Chassis	YES	YES	****	1.37	YES	YES	-

\* Heatsink number 223-0159 must be used when the output is above 5 Amps.  
 \*\*\* Isolated models can accept 0-10 VDC, 0 ±10 VDC, or 4-20 mA signals.  
 \*\*\*\* A field supply is not available on the RG60 family of drives. Minarik Drives recommends using the RG500 Series (pg 23).

### RG6xU DIMENSIONS

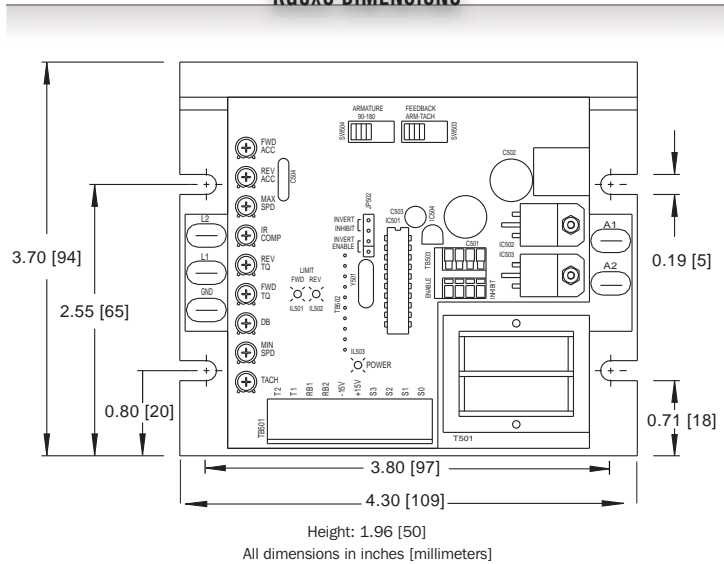

Dimensions of drives not shown above can be found on page 57.  
 Wiring diagrams of chassis drives can be found on pages 65 and 69.

### FEATURES

- **MM footprint:** Compact industry standard footprint.
- **4Q reversing:** Regenerative / 4 quadrant drives have the ability to perform quick, contactorless, reversing on-the-fly!
- **Speed range and regulation:** 2% regulation over 50:1 speed range. 0.5% over 60:1 speed range with the addition of a tachometer for feedback.
- **User adjustable calibration pots:** IR compensation, max speed, min speed, forward acceleration, reverse acceleration, forward torque, reverse torque, tachometer and deadband.
- **Diagnostic LEDs:** Power, forward current limit, reverse current limit.
- **Stopping modes:** Inhibit (N/O or N/C) to immediately brake to a stop. RB1 to RB2 (N/O) to decelerate to a stop. Enable (N/O or N/C) to coast to a stop.
- **Configurable enable and inhibit:** Can be configured to be either normally open or normally closed.
- **-PCM Option:** Isolation daughter card. Accepts 4-20 mA signals and non-isolated speed reference voltages between -10V and +10V.
- **-T Option:** Speed/torque adder card. Torque or speed control for both forward and reverse directions using a remote pot. (Not compatible with analog signal.)
- **Accessories:** Heatsink 223-0159, DLC600 digital closed loop controller, and 200-0386A limit switch logic board.

Minarik's RG60 Series is a compact, full-featured regen drive. Standard features include a choice of tachometer or armature feedback, nine trimmer pots including forward and reverse independent adjustments for acceleration and torque, cage clamp and plug-in terminal blocks for secure and easy connections and current limit LEDs. A unique feature on the RG60U is the ability to choose the enable and inhibit terminals to operate either 'normally open' or 'normally closed'.

The RG60U has two additional options available. The RG60U-PCM comes with isolation so that any +/- 10 VDC or 4-20 mA reference signal can be used. The RG60U-T comes with the ability to be used in torque or speed control using a remote pot. Torque control is useful in many web tensioning and winder applications.

Robust SCR technology with regenerative capability makes the RG60U especially ideal for high duty cycle and reversing applications.

See page 52 for an in-depth comparison of the different models of drives.



RG60U  
RG61U



RG60U-PCM  
RG61U-PCM

## Isolated SCR DC Regen Chassis

Drive	Input Voltage (VAC)	Output Voltage (VDC)	Max Current (ADC)	HP Rating @ 90 VDC Output	HP Rating @ 180 VDC Output	Enclosure	Reversing	Isolation ***	Field Supply (VDC) ****	Form Factor	UL	CUL	CE
RG5500U	115/230	0-90 / 0-180	25	1 - 2 1/2	1 - 5	Chassis	YES	YES	YES	1.37	YES	YES	-

\*\*\* Isolated models can accept 0-10 VDC, 0 - ±10 VDC, or 4-20 mA signals.

\*\*\*\* The field supply is rated at 3 Amps DC. A 50/100 VDC field is available with 115 VAC input, and a 100/200 VDC field is available with 230 VAC input.

C

Minarik's RG5500U drive is a full-wave, four quadrant regenerative drive which provides smooth motoring and braking torque for SCR brush-type DC motors. The RG5500U controls motors from 1 through 5 HP for single or bi-directional variable speed.

Applications with overhauling loads, rapid deceleration, basic positioning, and high duty cycle reversing or braking benefit from these versatile regenerative drives.

The RG5500U is excellent for leader/follower applications as well. It accepts almost any external signal input (see Isolated Inputs).

The RG5500U drive is conservatively rated at 25 Amps and is your answer for a full-featured regenerative drive requirement up to 5 HP. The robust 3 Amp field makes the drive a suitable replacement for older shunt wound motor drive systems.

See page 52 for an in-depth comparison of the different models of drives.



RG5500U

### RG5500U DIMENSIONS

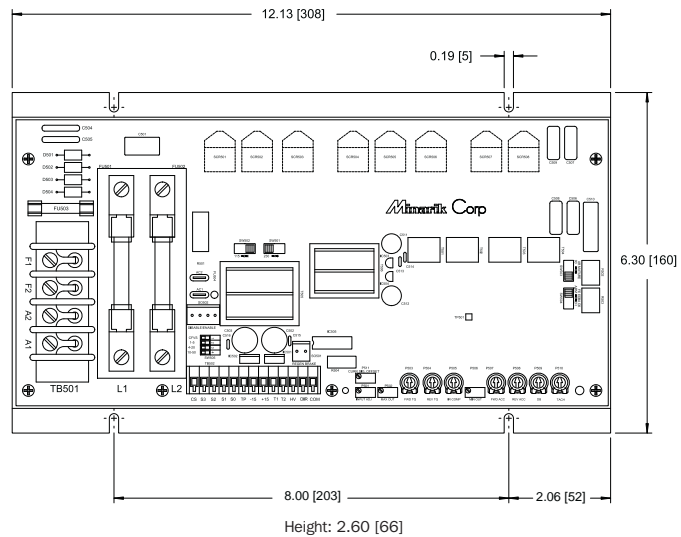



Height: 2.60 [66]

All dimensions in inches [millimeters]

Wiring diagrams of chassis drives can be found on pages 65 and 69.

### FEATURES

- **Isolated inputs:** Accepts floating or grounded signals of -250 to +250 VDC, -25 to +25 VDC, -10 to +10 VDC or 4-20 mA. Burr-Brown isolation has .01% linearity.
- **4Q reversing:** Regenerative / 4 quadrant drives have the ability to perform quick, contactorless reversing on-the-fly!
- **Speed range and regulation:** 1% regulation over 50:1 speed range. 0.1% regulation over 60:1 speed range with the addition of a tachometer. Armature or tachometer mode is switch selectable.
- **User adjustable calibration pots:** IR compensation, min speed, max speed, forward acceleration, reverse acceleration, forward torque, reverse torque, deadband, input adjust (for speed reference input) and tachometer.
- **Stopping Modes:** Inhibit (N/O) to immediately break to a stop. RB1 and RB2 to decelerate to a stop.
- **Cage clamp terminal block:** Quick and easy wire terminations reduce installation time!
- **Additional features:** On-board fusing.

Drive	Input Voltage (VAC)	Output Voltage (VDC)	Max Current (ADC)	HP Rating @ 90 /130 VDC Output	HP Rating @ 180 VDC Output	Enclosure	Reversing *****	Isolation ***	Field Supply (VDC)	Form Factor	UL 	CUL 	CE 
NRG02-D240AC-4Q	115/230	0-130 / 0-240	2	1/20 - 1/4	1/10 - 1/3	Chassis	YES	-	-	1.05	YES	YES	YES
NRG02-D240AC-4Q-PCM	115/230	0-130 / 0-240	2	1/20 - 1/4	1/10 - 1/3	Chassis	YES	YES	-	1.05	YES	YES	YES
NRG05-D240AC-4Q	115/230	0-130 / 0-240	5	1/8 - 1/2	1/4 - 1	Chassis	YES	-	-	1.05	YES	YES	YES
NRG05-D240AC-4Q-PCM	115/230	0-130 / 0-240	5	1/8 - 1/2	1/4 - 1	Chassis	YES	YES	-	1.05	YES	YES	YES
NRG10-115AC-4Q	115	0-130	10	1/4 - 1	-	Chassis	YES	-	-	1.05	YES	YES	YES
NRG10-115AC-4Q-PCM	115	0-130	10	1/4 - 1	-	Chassis	YES	YES	-	1.05	YES	YES	YES

\*\*\* Isolated models can accept 0-10 VDC or 0 - ±10VDC signals.

\*\*\*\*\*Applications that require braking and/or reversing of high inertia loads require a Regenerative Dumping resistor. Consult NRG-4Q manual or Minarik Drives factory for details.

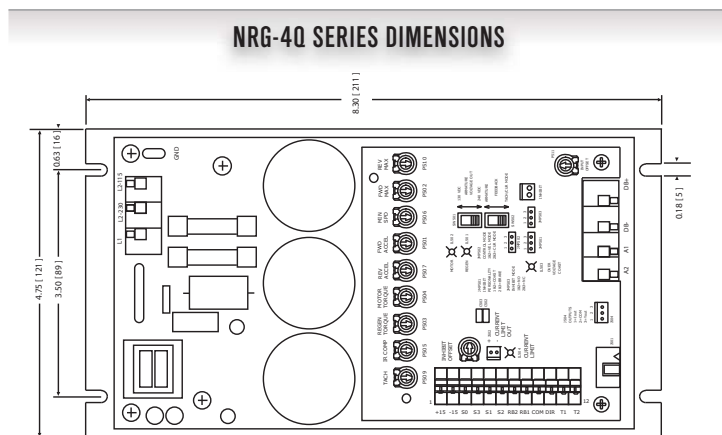

MODEL	HEIGHT
NRG02-D240AC-4Q	2.79 [ 71 ]
NRG05-D240AC-4Q	3.13 [ 80 ]
NRG10-115AC-4Q	3.62 [ 92 ]

All dimensions in inches [millimeters]

Wiring diagrams of chassis drives can be found on pages 65 and 69.

## FEATURES

- **4Q reversing:** Regenerative / 4 quadrant drives have the ability to perform quick, contactorless reversing on-the-fly!
- **Speed range and regulation:** 1% regulation over 100:1 speed range. 0.1% regulation over 100:1 speed range with the addition of a tachometer for feedback. Armature or tachometer mode is switch selectable.
- **User adjustable calibration pots:** IR compensation, motor torque, regen torque, tachometer, min speed, forward max speed, reverse max speed, forward acceleration, reverse acceleration, inhibit offset, and input offset.
- **Diagnostic LEDs:** LEDs for motoring, regen (torque or braking), current limit and overvoltage coast.
- **Stopping modes:** User can decelerate (N.O.), regeneratively brake (N.O. or N.C.) or coast the motor to a stop (N.O. or N.C.).
- **Outputs:** Signals proportional to motor voltage, motor current, and to signal the drive is in current limit.
- **Inhibit personality switch:** Choose whether you brake or coast to a stop. Use inhibit plug (201-0024).
- **Auto-ranging power supply:** Can accept a 90-240VAC or 80-340VDC as an alternative to an AC input. Connection will vary.

The NRG-4Q Series, with a robust set of features, is easy to use and at the same time, will satisfy demanding application requirements. This family of drives is the highest performance drive line in the Minarik Drives arsenal. Our OEM customers often refer to the drive as a DC Servo. In addition to on-board fusing to protect your motor and drive, the NRG will accept any AC input voltage between 90 and 240 VAC at 50 or 60Hz. With the auto-ranging power supply there are no switches to set, no settings to change.

These highly efficient, near unity form factor PWM regenerative drives will increase motor performance while reducing your energy costs. MOSFET power in PWM drives switch at 16kHz (double edge modulation), to provide fast circuit response and the constant 1.05 (pure DC is 1.00) form factor throughout the entire 100:1 speed range.

The NRG-4Q will work with logic signals, motion controllers, and programmable logic controllers. It is also compatible with Minarik's popular 200-0386A limit switch logic board. (page 45)

See page 52 for an in-depth comparison of the different models of drives.



NRG02-D240AC-4Q  
 NRG02-D240AC-4Q-PCM  
 NRG05-D240AC-4Q  
 NRG05-D240AC-4Q-PCM  
 NRG10-115AC-4Q  
 NRG10-115AC-4Q-PCM

## Non-Geared DC Motor

D

PART NUMBER	MOTOR POWER (HP)	SHAFT SPEED (RPM)	CONTINUOUS TORQUE (in-lbs)	SPEED REDUCTION (ratio: 1)	TERMINAL VOLTAGE (VDC)	RATED CURRENT (cont.) (Amps)	NEMA
506-07-027	1/4	1750	9	N/A	90*	2.5	56C
506-07-028	1/3	1750	12	N/A	90*	3.50	56C
506-07-029	1/2	1750	18	N/A	90*	5.00	56C
506-07-038	1/2	2500	12	N/A	90*	5.00	56C
506-37-029	1/2	1750	18	N/A	180**	2.5	56C
506-07-030	3/4	1750	27	N/A	90*	7.60	56C
506-06-131	1	1750	36	N/A	90*	10.0	56C

\* Motor windings rated for 130 VDC

\*\* Motor windings rated for 240 VDC



## FEATURES

- Low profile space-saving design.
- Large oversized brushes assure longer life.
- Heavy-duty, stamped steel, bolt-on base (removable).
- Permanently lubricated double shielded ball bearings.
- Capable of dynamic braking for faster stops.
- Permanent magnet brush DC motors.
- Framed motors designed to operate with SCR or PWM drives powered by 115 VAC or 230 VAC input.

Additional DC motors may be found at [www.minarikdrives.com](http://www.minarikdrives.com)

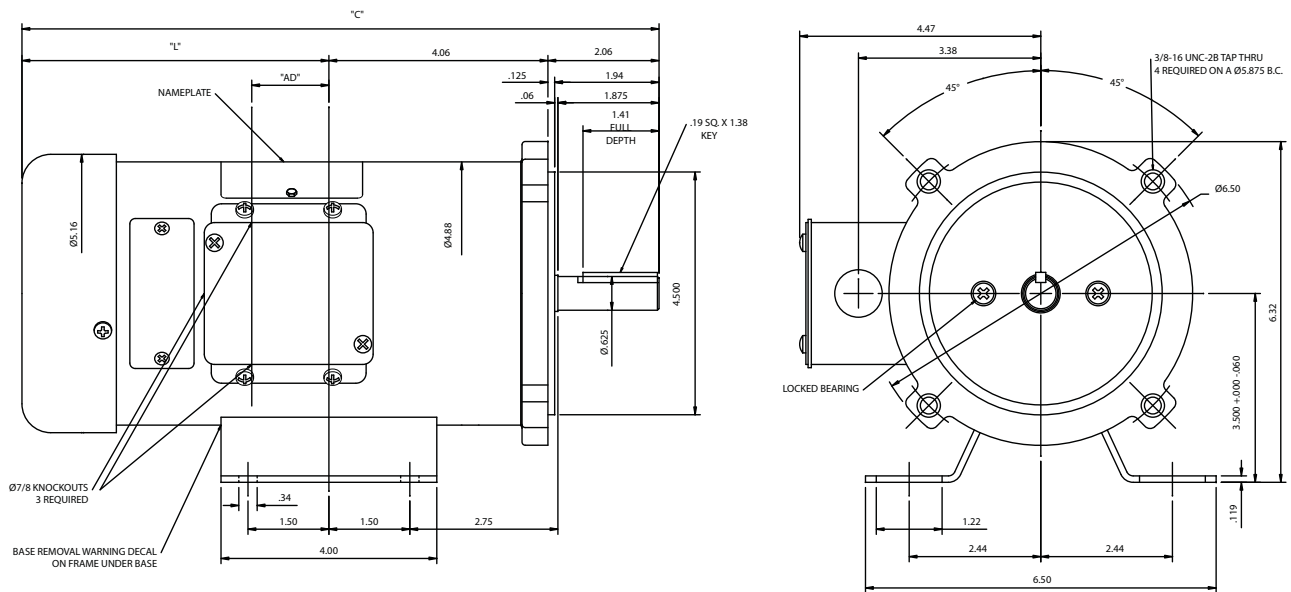

506-07-030	13.81	7.69	3.44
506-07-029	11.81	5.69	1.44
506-07-027	10.81	4.69	.44
MODEL NO.	"C"	"L"	"AD"

ALL DIMENSIONS ARE IN INCHES

D

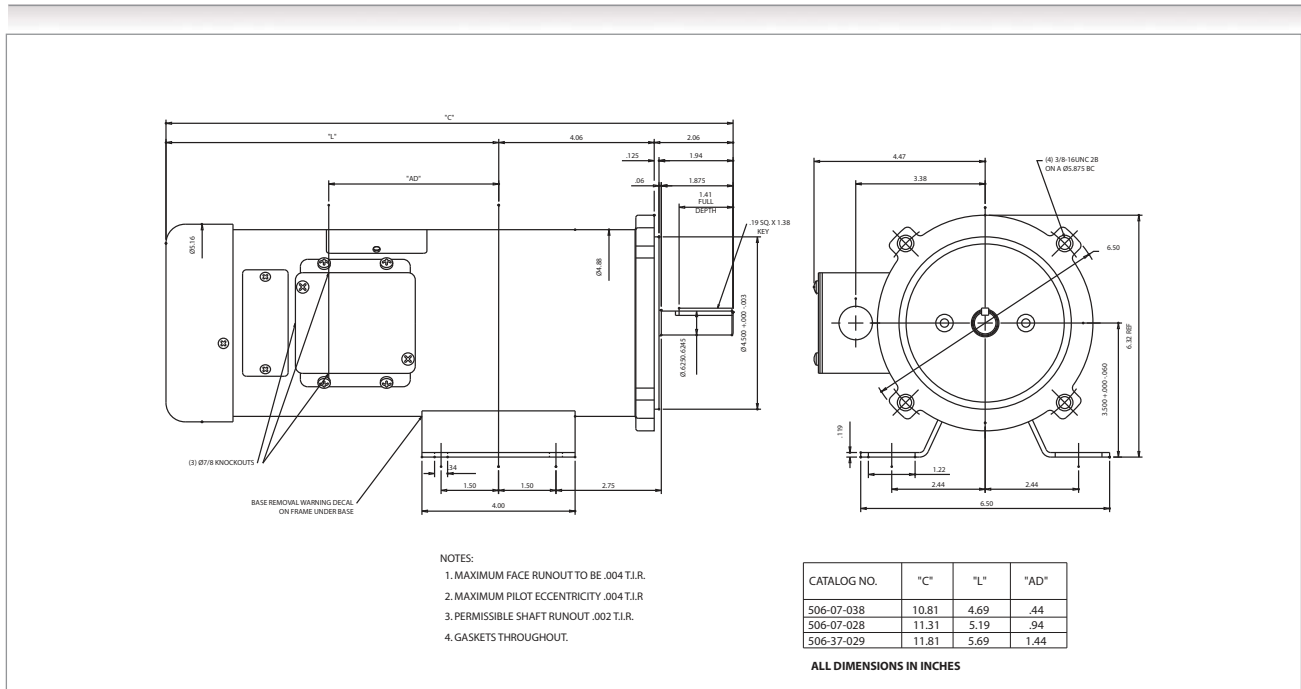

( 506-07-038, 028, 506-37-029 )

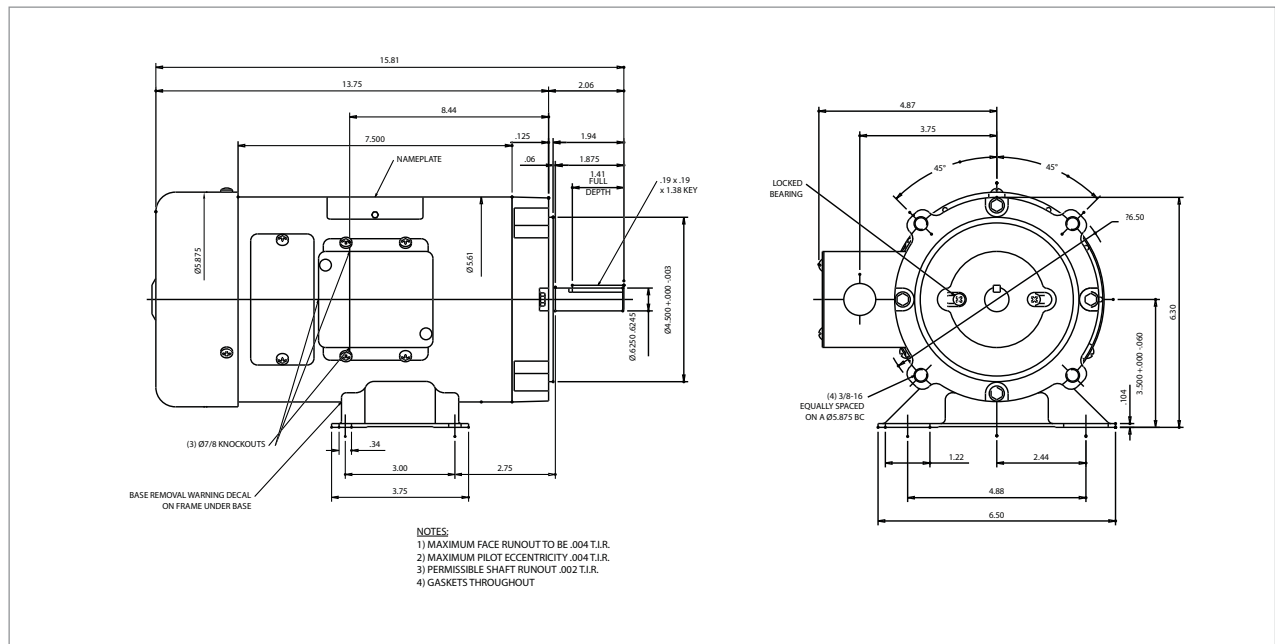

( 506-06-131 )

## In-Line DC Gearmotors

D

PART NUMBER	MOTOR POWER ( HP )	SHAFT SPEED ( RPM )	CONTINUOUS TORQUE ( in-lbs )	SPEED REDUCTION ( ratio: 1 )	TERMINAL VOLTAGE ( VDC )	RATED CONTINUOUS CURRENT ( Amps )
510-09-002	1/20	10	100	180	90*	0.54
510-18-002	1/20	10	100	180	180**	0.31
507-01-131	1/20	49	55	36.7	90*	0.60
507-01-130	1/20	71	40	25.2	90*	0.60
507-01-129	1/20	139	20	12.9	90*	0.60
507-01-127	1/20	359	8	5	90*	0.60
510-09-021	1/8	7	330	336	90*	0.70
510-18-021	1/8	7	330	336	180**	0.35
507-01-109	1/8	30	230	60.2	90*	1.25
507-01-108	1/8	64	112	28.1	90*	1.25
507-01-106	1/8	170	42	10.6	90*	2.7
510-09-035	1/4	18	750	95	90*	2.7
510-18-023	1/4	21	371	124	180**	0.55
510-09-037	1/4	60	238	29	90*	2.7
510-18-027	1/4	62	220	43	180**	1.20
510-09-029	1/4	125	100	23	90*	2.00
510-09-031	1/4	250	45	10	90*	2.00
510-09-032	1/4	500	25	5	90*	2.00
510-09-041	1/2	30	822	53	90*	5.0
510-09-043	1/2	60	476	29	90*	5.0

\* Motor windings rated for 130 VDC

\*\* Motor windings rated for 240 VDC

### FEATURES

- Precision machined die cast aluminum.
- Oil filled, sealed and gasketed gear boxes.
- Hardened steel shaft.
- Permanent magnet brushed DC motors, TENV.
- Framed motors designed to operate with SCR or PWM drives powered by 115 VAC or 230 VAC input.

Additional in-line DC gearmotors along with right angle DC gearmotors may be found at [www.minarikdrives.com](http://www.minarikdrives.com)





D

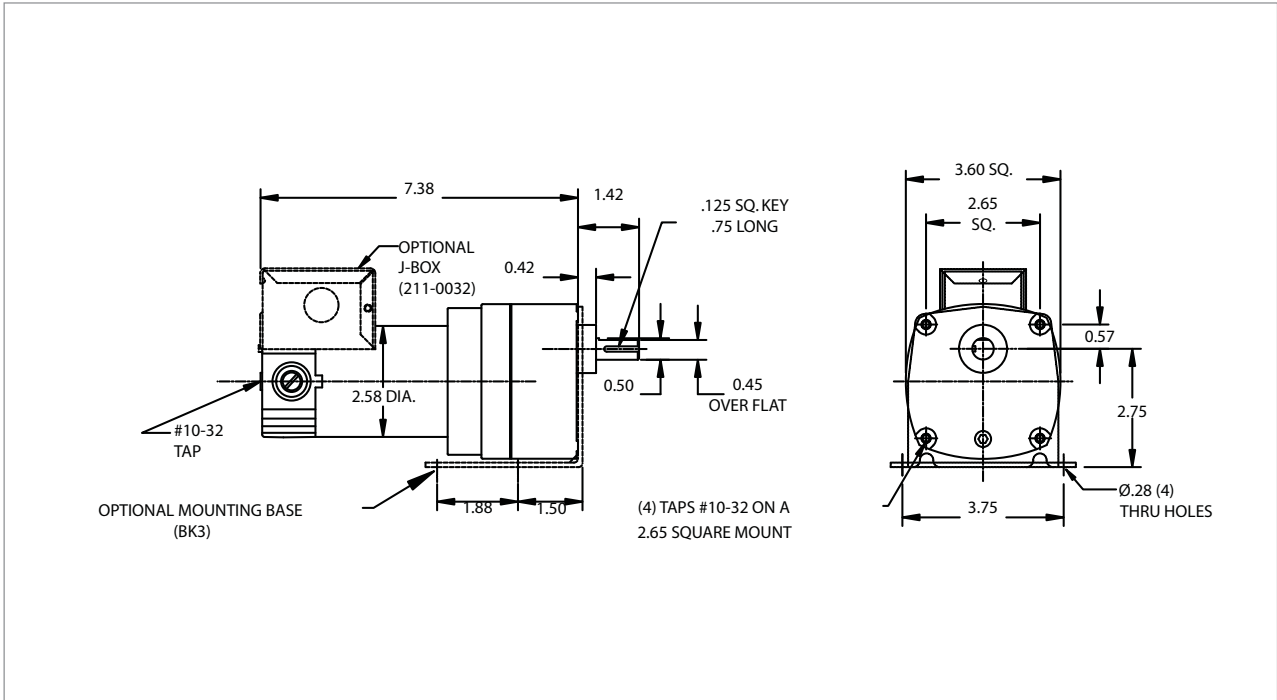

**1/20 HP ( 507-01-127, 129, 130, 131 )**

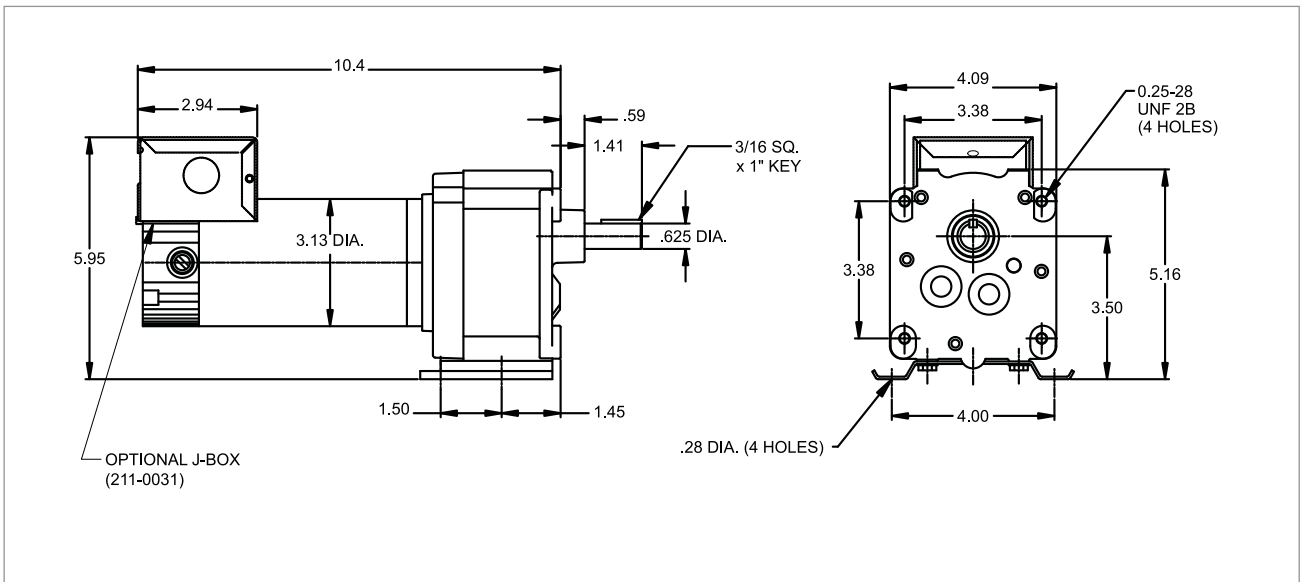

**1/8 HP ( 507-01-106, 108, 109 )**

D

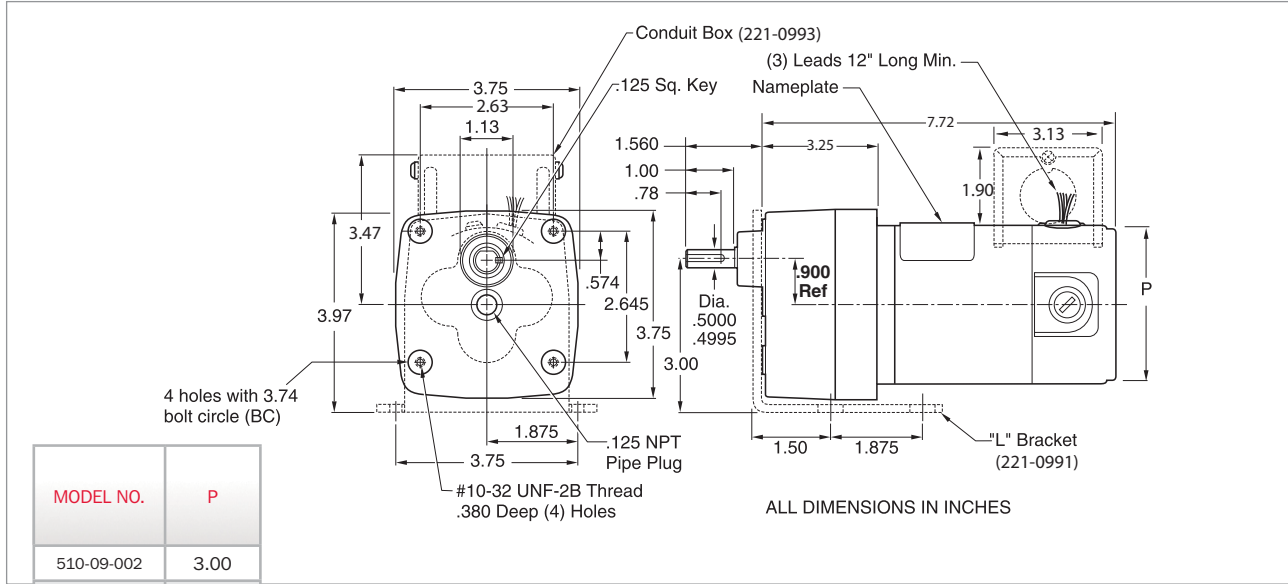

510-09-002 / 510-18-002

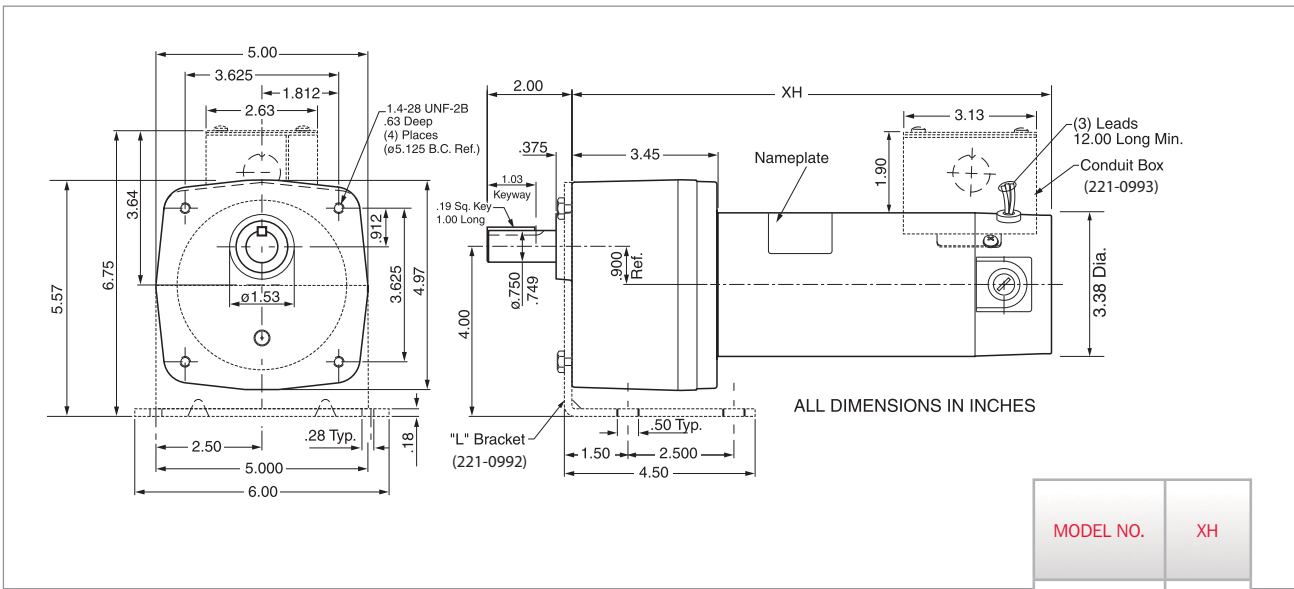

510-09-0XX / 510-18-0XX

MODEL NO.	XH
510-09-021	9.31
510-18-021	9.31
510-18-023	11.31
510-18-027	11.31
510-09-029	11.31
510-09-031	11.31
510-09-032	11.31

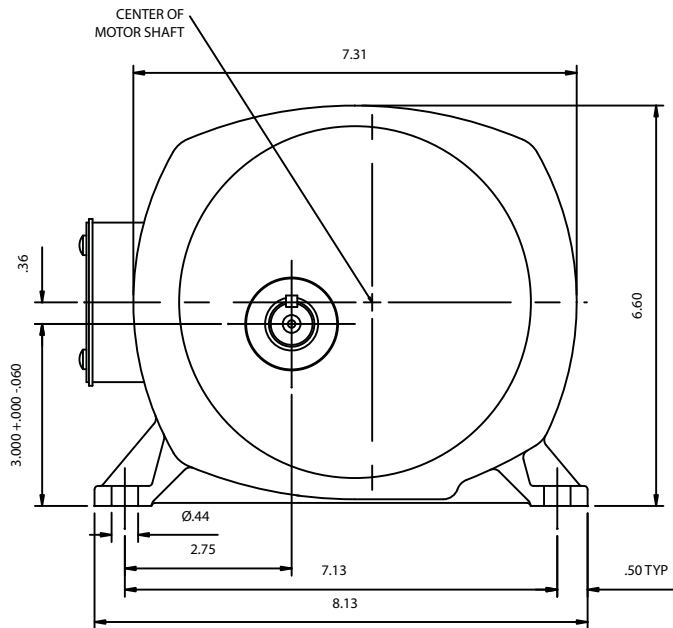
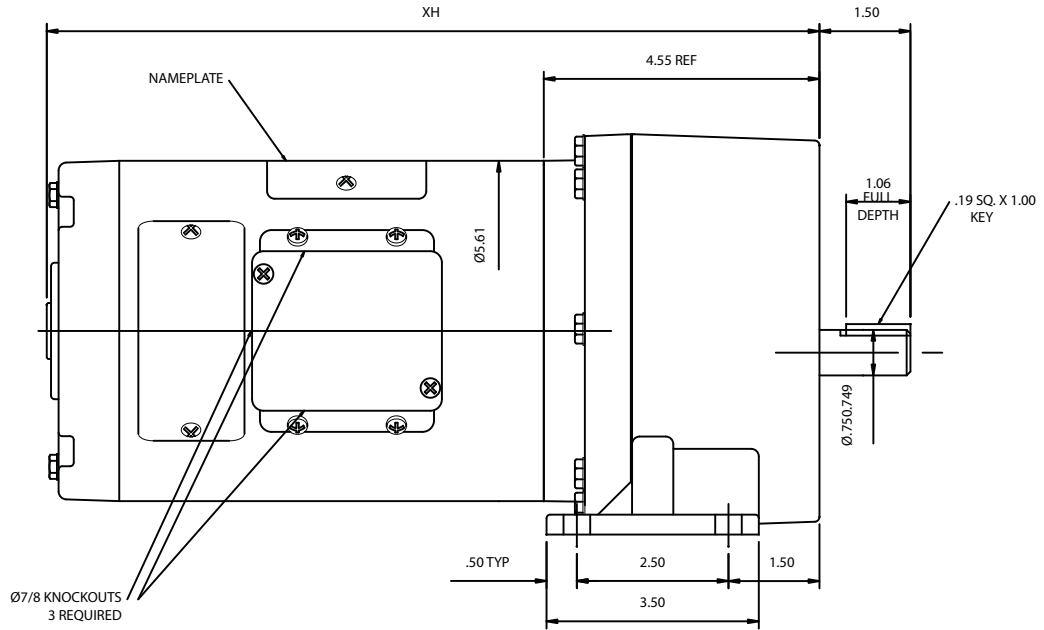

D



MODEL NO.	XH
510-09-035	12.74
510-09-037	12.74
510-09-041	14.99
510-09-043	14.99

510-09-OXX

**TA10-D Microprocessor Based AC Triac Drive**

Model Number	Input Voltage (VAC)	Output Voltage (VAC)	Max Current (Amps)	HP Rating @ 115 VAC Output	HP Rating @ 230 VAC Output	Enclosure	Reversing	Isolation	UL 	CUL 	CE 
TA10-D	115/230	0-115 / 0-230	10	1	2	-	-	-	P	P	-

P: Pending

**E**

The TA10-D drive delivers the features and benefits of a microprocessor based drive, and the low cost of a triac control. This control is perfect to control speed of a single phase AC motor. Do not use a TA10-D on three phase motors.

The industrial strength TA10-D has a continuous current rating of 10 Amps at 115 VAC or 230 VAC. Other common triac drives are unable to maintain a steady voltage (speed) to the motor as the AC line voltage sags or swells. However, the internal closed loop circuit on the TA10-D drive compensates for changing AC line voltages while maintaining a steady voltage to the motor, thereby maintaining speed.

The Minarik TA10-D drive takes advantage of single phase motor characteristics to provide approximately constant pressure in filtered fan applications. As the filter becomes clogged, the motor will speed up to maintain airflow.

The TA10-D is also capable of accepting a feedback signal. This feature is most commonly found in exhaust systems where a thermistor is used for feedback to maintain a set temperature. The drive can also take a set point voltage signal to create PI closed loop system.

The TA10-D controls single phase permanent split capacitor (PSC), shaded pole, synchronous and universal motors.

See page 53 for an in-depth comparison of the different models of drives.



TA10-D

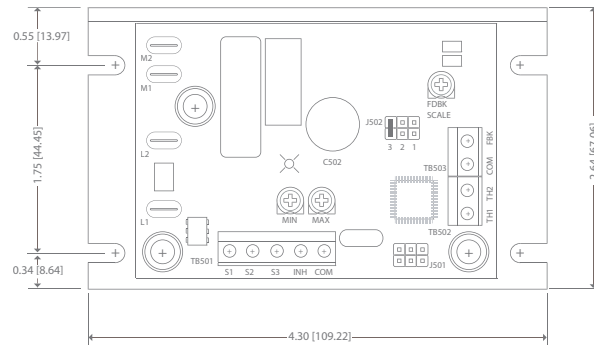

**TA10-D DRIVE DIMENSIONS**



Height: 1.41 [36]  
 All dimensions in inches [millimeters]  
 Wiring diagrams of chassis drives can be found on page 66.

**FEATURES**

- **Size:** Small footprint uses minimal panel space.
- **Microprocessor based:** Allows custom programming for OEMs.
- **Autoranging input:** No voltage switches to set.
- **AC line voltage compensation:** Holds a steady output voltage even if the input voltage fluctuates.
- **User adjustable calibration pots:** Minimum Speed, Maximum Speed, and optional feedback calibrating.
- **Variety of motors:** Single phase Permanent Split Capacitor (PSC), Shaded Pole, Synchronous and universal motors.
- **Do not use with:** Single Phase Capacitor Start, Split Phase or any other single phase motors that use a centrifugal switch in the start winding.
- **Feedback:** Optional PI closed loop control or thermistor feedback.
- **Low cost:** Triac drives are a cost effective alternative to a traditional VFD.

Drive	Input Voltage (VAC)	Output Voltage (VAC)	Max Current (Amps)	HP Rating @ 115 VAC Output	HP Rating @ 230 VAC Output	Enclosure	Reversing	Isolation	UL 	CUL 	CE 
VFD02-115AC	115	0-115	2.4	1/16 - 1/4	–	Chassis	YES	***	YES	YES	–
VFD02-230AC	230	0-230	2.4	–	1/8 - 1/2	Chassis	YES	***	YES	YES	–
VFD02-D230AC	115/230	0-230	2.4	–	1/8 - 1/2	Chassis	YES	***	YES	YES	–
VFD04-115AC	115	0-115	4	1/8 - 1/2	–	Chassis	YES	***	YES	YES	–
VFD04-230AC	230	0-230	4	–	1/4 - 1	Chassis	YES	***	YES	YES	–
VFD04-D230AC	115/230	0-230	4	–	1/4 - 1	Chassis	YES	***	YES	YES	–

\*\*\* Isolated models can accept a 0-5 VDC, 0-10 VDC, or 4-20 mA signals. To add isolation use field installable kit part number 200-0422.

E

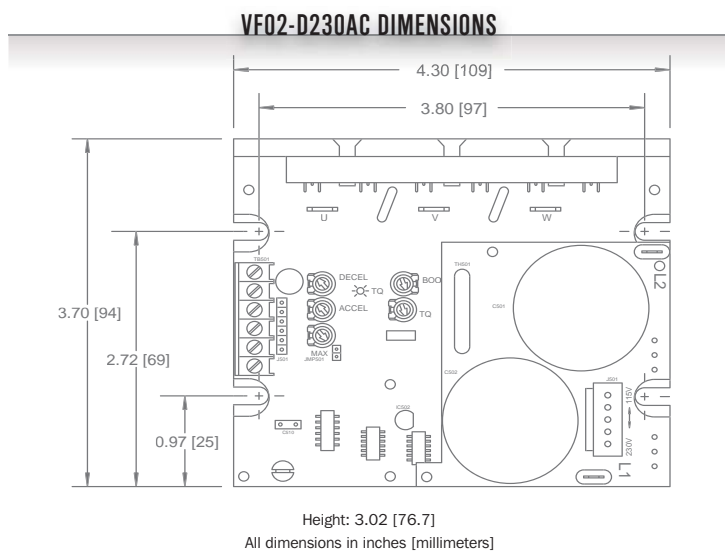

Dimensions of drives not shown above can be found on page 57 and 58.  
Wiring diagrams of chassis drives can be found on pages 66 and 67.

### FEATURES

- **Compact size:** Same bolt pattern as MM footprint industry standard mounting hole pattern.
- **“D” models can double the output:** Enables the use of a 230 VAC single or three phase motor with a 115 VAC single-phase supply. Do not use 115 VAC motors on “D” models.
- **Use with a variety of motors:** Can be used with 3-phase induction and single-phase permanent split capacitor (PSC), shaded pole and synchronous motors.
- **Easy to calibrate & set-up:** On-board trimmer pot adjustments for boost, maximum speed, acceleration, deceleration, and torque limit.
- **Torque ‘foldback’ feature:** Allows up to 200% torque for short periods to overcome intermittent peak loads, then reduces the torque to a (preset) safe level.
- **Optional isolation:** Order a 200-0422 field installable isolation kit for isolation of all inputs. The 200-0422 is a small daughter card that plugs into and mounts on the top of the drive.

The Volts/Hertz VFD Series has several models in the 1/16 - 1 HP range that accept 115 VAC and 230 VAC power. Dual input voltage “D” versions have a jumper that causes the drive to output double the voltage, allowing the use of 230 VAC motors when only a 115 VAC power is available. The VFD Series was designed to “look and feel” like a DC drive. This means quick and easy setup with **no programming required**.

With its compact size, standard features, and application flexibility, the VFD Series is an excellent choice for most 1 HP and under AC applications. The VFD Series can also run single phase permanent split capacitor (PSC), shaded pole, and synchronous motors.

See page 53 for an in-depth comparison of the different models of drives.



VFD02-115AC  
VFD02-230AC

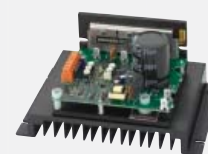

VFD04-115AC  
VFD04-230AC



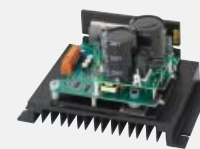

VFD02-D230AC



VFD04-D230AC

**Isolated PWM AC Chassis, NEMA 4X**

Drive	Input Voltage (VAC)	Output Voltage (VAC)	Max Current (Amps)	HP Rating @ 115 VAC Output	HP Rating @ 230 VAC Output	Enclosure	Reversing	Isolation ***	UL 	CUL 	CE 
VFDA4X04-D230-PCM	115/230	0-230	4	-	1/6 - 1	NEMA 4X	YES	YES	YES	YES	-
VDF4X04-D230-PCM	115/230	0-230	4	-	1/6 - 1	NEMA 4X	YES	YES	YES	YES	-
VFD4X04-D230-PCM	115/230	0-230	4	-	1/6 - 1	NEMA 4X	YES	YES	YES	YES	-
VFD05-D230-PCM	115/230	0-230	5	-	3/8 - 1 1/2	Chassis	YES	YES	YES	YES	-
VFDS4X05-D230-PCM	115/230	0-230	5	-	3/8 - 1 1/2	NEMA 4X	YES	YES	YES	YES	-

\*\*\* Isolated models can accept a 0-5 VDC, 0-10 VDC, or 4-20 mA signals.

E

The Volts/Hertz, PWM, VFD-PCM Series have all the features of the original VFD Series with several enhancements. They include a rugged steel, plastic, or aluminum NEMA 4X enclosure, an isolated front end, minimum speed adjustment potentiometer (pot), output voltage doubling, DC injection braking, and automatic or manual restart when power is restored. The VDF4X04-D230AC-PCM enclosure is painted in a white epoxy and is USDA rated-perfect for food and washdown environments!

The VFD-PCM Series accepts reference signals that are 0-5 VDC, 0-10 VDC or 4-20 mA without an additional isolation card. The DC injection braking feature comes with two additional calibration potentiometers (Braking Current and Braking Time) for easy set up. There is never a need to program the VFD-PCM Series.

The dual voltage VFD-PCM series has a “doubling” jumper that can be set to output 230 VAC to the motor when only 115 VAC is available. Another jumper selectable option is for choosing automatic or manual restarting.

The features, flexibility and compact size of the VFD-PCM Series make it the ideal choice for AC motor applications under 1.5 HP in adverse surroundings.

See page 53 for an in-depth comparison of the different models of drives.



VFDS4X05-D230-PCM



VFD05-D230-PCM



VFD4X04-D230-PCM



VFDA4X04-D230-PCM\*  
VDF4X04-D230-PCM

\*Model has a grey enclosure.

**VFD05-D230-PCM DIMENSIONS**

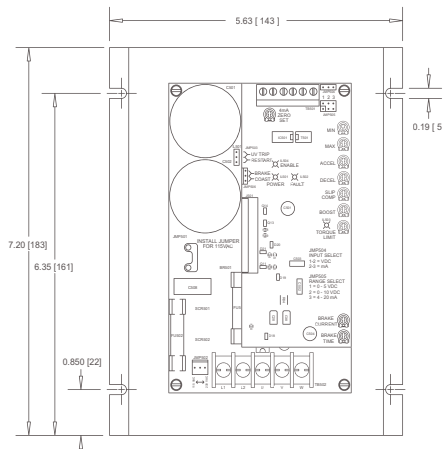

Height: 3.30 [84]

All dimensions in inches [millimeters]

Dimensions of drives not shown above can be found on page 58. Wiring diagrams of chassis drives can be found on page 67.

**FEATURES**

- **Enclosure Options:** Chassis or NEMA 4X with steel, plastic, or aluminum models. On aluminum models choose gray or USDA rated white epoxy.
- **Isolated inputs:** Accepts floating or grounded signals 0-10 VDC, 0-5 VDC or 4-20 mA.
- **Doubler mode:** Enables the use of a 230 VAC single or three phase motor with a 115 VAC single-phase supply. Do not use 115 VAC motors on these models.
- **Control a variety of motors:** 3-phase induction motors, single-phase permanent split capacitor (PSC), shaded pole and synchronous motors.
- **User adjustable calibration pots:** Minimum speed, maximum speed, current limit, acceleration, deceleration, slip compensation, boost, zero set, brake current, and brake time. No programming necessary.
- **Diagnostic LED's:** Power, Fault, Enable and Torque limit.
- **Stopping modes:** DC injection braking or coast (jumper selectable).
- **Adjustable 4 to 16kHz switching frequency:** Quiet motor operation or reduced electrical noise.
- **Torque “foldback”:** Allows up to 200% torque to overcome intermittent peak loads.
- **Additional features:** Auto or manual restart after low input voltage fault (jumper selectable), line fusing, isolated enable and direction inputs.

MODELS	INPUT VOLTAGE (VAC)	INPUT PHASE	OUTPUT VOLTAGE (VAC)	HP RATING	OUTPUT CURRENT (AMPS)	SIZE*
ACM110S-0.25	120	1	0-200/230	1/3	1.7	A5
ACM110S-0.4	120	1	0-200/230	1/2	2.4	A5
ACM110S-0.75	120	1	0-200/230	1	4.2	B5
ACM110S-1.1	120	1	0-200/230	1 1/2	6.0	B5
ACM112S-0.25	208/240	1	0-200/230	1/3	1.9/1.7	A5
ACM112S-0.4	208/240	1	0-200/230	1/2	2.8/2.4	A5
ACM112S-0.55	208/240	1	0-200/230	3/4	3.7/3.2	A6
ACM112S-0.75	208/240	1	0-200/230	1	4.8/4.2	A6
ACM112S-1.1	208/240	1	0-200/230	1 1/2	6.9/6.0	B5
ACM112S-1.5	208/240	1	0-200/230	2	8.1/7.0	B5
ACM112S-2.2	208/240	1	0-200/230	3	11.0/9.6	B6
ACM112T-0.4	208/240	3	0-200/230	1/2	2.8/2.4	A5
ACM112T-0.75	208/240	3	0-200/230	1	4.8/4.2	A6
ACM112T-1.1	208/240	3	0-200/230	1 1/2	6.9/6.0	A7
ACM112T-1.5	208/240	3	0-200/230	2	8.1/7.0	A7
ACM112T-2.2	208/240	3	0-200/230	3	11.0/9.6	B6
ACM112T-3.7	208/240	3	0-200/230	5	17.5/15.2	B2
ACM114T-0.4	400/480	3	0-400/460	1/2	1.3/1.1	A8
ACM114T-0.75	400/480	3	0-400/460	1	2.5/2.1	A9
ACM114T-1.1	400/480	3	0-400/460	1 1/2	3.6/3.0	A10
ACM114T-1.5	400/480	3	0-400/460	2	4.1/3.4	A10
ACM114T-2.2	400/480	3	0-400/460	3	5.8/4.8	B1
ACM114T-3.7	400/480	3	0-400/460	5	9.4/7.8	B2

\* For dimensional details see page 38.

## FEATURES

- **Isolation:** Inputs and outputs are isolated and allow any speed reference signal to be accepted.
- **Programmable:** Programmed via the front keypad, or hand-held EPM programmer.
- **Reversing:** Solid-state devices make reversing as simple as closing a contact.
- **Display:** 3-digit seven segment display for programming, status, and diagnostics.
- **Braking:** DC injection braking is standard with a dynamic braking option available when faster, repetitive stops are needed.
- **Carrier frequency:** Adjustable from 4 to 10 kHz to help reduce the audible noise from the motor.
- **Automatic restart:** Can be programmed to automatically restart upon application of power.
- **Default settings:** Drives ship with default settings requiring only a few inputs to be off and running.
- **For use with 3-phase motors only**

The ACM100 Series variable frequency, V/Hz drive is a programmable easy to use drive in an IP20 enclosure. It has a 3-digit seven segment display for programming, drive status, and diagnostics. The ACM100 Series has nine isolated inputs and outputs including stop/run, 0-10 VDC input, 4-20mA input, 10 VDC supply for speed pot, DC supply for digital inputs, open collector output, and three programmable inputs.



**E**

The AC200 Series variable frequency, V/Hz drive is a compact, low-cost solution for AC motor control. The AC200 contains extensive I/O and full programming menu typically found in more expensive drives. This series has a 3-digit seven segment display for programming, drive status, and diagnostics. The AC200 has eighteen isolated inputs and outputs including start, stop, 0-10 VDC input, 4-20 mA input, 10VDC supply for external potentiometer, 12 VDC supply for an external relay, two open collector outputs, two analog outputs, three programmable inputs, and RS485 (RXA, RXB).

In addition, the AC200 Series has several options that include: a 1000 Hz output frequency option for very high speed applications, throughhole mounting capability that puts the heat sink outside the drive enclosure for better thermal management, and dynamic braking resistor modules for applications that require quick stops. The AC200 Series is a great choice when drive control is done from remote locations by process control (analog references of 0-10 VDC or 4-20 mA) or serial communications.



**FEATURES**

- **Isolation:** Inputs and outputs are isolated and allow any speed reference signal to be accepted.
- **Programmable:** Programmed using the front keypad, remote keypad, hand-held EPM programmer, Modbus, or through your PC using the Techlink software.
- **Reversing:** Solid-state devices make reversing as simple as closing a contact.
- **Display:** 3-digit seven segment display for programming, status and diagnostics.
- **Braking:** DC injection braking is standard with a dynamic braking option available when faster repetitive stops are needed.
- **Carrier frequency:** Adjustable from 4 to 10 kHz to help reduce the audible noise from the motor.
- **Automatic restart:** Can be programmed to automatically restart upon application of power.
- **For use with 3-phase motors only**

**48 programmable parameters that include:**

- Four or more ways to start and stop the motor
- Two adjustable acceleration & deceleration times (.1 to 3600 seconds)
- DC injection braking time and voltage
- Maximum (999Hz) and minimum (0Hz) frequency
- Current limit and motor overload
- Fixed and adjustable acceleration boost
- Slip compensation
- Seven pre-set speeds
- And many more!

**ACM100 & AC200 DIMENSIONS**

SIZE	HEIGHT	WIDTH	DEPTH
A1	5.75 (146)	2.88 (73)	3.76 (96)
A2	5.75 (146)	2.88 (73)	4.56 (116)
A3	5.75 (146)	2.88 (73)	5.56 (141)
A5	5.75 (146)	2.88 (73)	3.26 (83)
A6	5.75 (146)	2.88 (73)	3.63 (92)
A7	5.75 (146)	2.88 (73)	5.56 (141)
A8	5.75 (146)	2.88 (73)	3.94 (100)
A9	5.75 (146)	2.88 (73)	4.74 (120)
A10	5.75 (146)	2.88 (73)	5.74 (146)
B1	5.75 (146)	3.76 (96)	5.24 (133)
B2	5.75 (146)	3.76 (96)	6.74 (171)
B5	5.75 (146)	3.76 (96)	4.88 (124)
B6	5.75 (146)	3.76 (96)	5.53 (140)
C1	7.75 (197)	5.02 (128)	7.18 (182)
D1	9.75 (273)	6.68 (170)	8.00 (203)



## AC200 SERIES SPECIFICATIONS

MODELS	INPUT VOLTAGE (VAC)	INPUT PHASE	OUTPUT VOLTAGE (VAC)	HP RATING	OUTPUT CURRENT (AMPS)	SIZE*
AC211S-0.75	208/240	1	0-200/230	1	4.6/4.0	B1
AC211S-1.1	208/240	1	0-200/230	1.5	6.2/5.4	B1
AC212B-0.2	208/240	1/3	0-200/230	1/4	1.6/1.4	A8
AC212B-0.4	208/240	1/3	0-200/230	1/2	2.5/2.2	A8
AC212B-0.75	208/240	1/3	0-200/230	1	4.6/4.0	A9
AC212B-1.1	208/240	1/3	0-200/230	1.5	6.2/4.4	B1
AC212B-1.5	208/240	1/3	0-200/230	2	7.8/6.8	B2
AC212B-2.2	208/240	1/3	0-200/230	3	11.0/9.6	B2
AC212B-3.7	208/240	1/3	0-200/230	5	17.5/15.2	C1
AC212T-0.75	208/240	3	0-200/230	1	4.6/4.0	A9
AC212T-1.1	208/240	3	0-200/230	1.5	6.2/4.4	A10
AC212T-1.5	208/240	3	0-200/230	2	7.8/6.8	A10
AC212T-2.2	208/240	3	0-200/230	3	11.0/9.8	A10
AC212T-3.7	208/240	3	0-200/230	5	17.5/15.2	B2
AC212T-5.5	208/240	3	0-200/230	7.5	25.3/22.0	C1
AC212T-7.5	208/240	3	0-200/230	10	30.0/28.0	C1
AC212T-11	208/240	3	0-200/230	15	48/42	D1
AC212T-15	208/240	3	0-200/230	20	58/54	D1
AC214T-0.4	400/480	3	0-400/460	1/2	1.3/1.1	A8
AC214T-0.75	400/480	3	0-400/460	1	2.4/2.1	A9
AC214T-1.1	400/480	3	0-400/460	1.5	3.1/2.7	A10
AC214T-1.5	400/480	3	0-400/460	2	3.9/3.4	A10
AC214T-2.2	400/480	3	0-400/460	3	5.5/4.8	A10
AC214T-3.7	400/480	3	0-400/460	5	8.7/7.6	B2
AC214T-5.5	400/480	3	0-400/460	7.5	12.6/11.0	C1
AC214T-7.5	400/480	3	0-400/460	10	16.1/14.0	C1
AC214T-11	400/480	3	0-400/460	15	24/21	D1
AC214T-15	400/480	3	0-400/460	20	31/27	D1
AC214T-18.5	400/480	3	0-400/460	25	39/34	D1
AC215T-0.75	480/590	3	0-460/575	1	1.9/1.7	A9
AC215T-1.5	480/590	3	0-460/575	2	3.4/3.0	A10
AC215T-2.2	480/590	3	0-460/575	3	4.2/4.2	B2
AC215T-3.7	480/590	3	0-460/575	5	6.6/6.6	B2
AC215T-5.5	480/590	3	0-460/575	7.5	9.9/9.9	C1
AC215T-7.5	480/590	3	0-460/575	10	12.2/12.2	C1
AC215T-11	480/590	3	0-460/575	15	19/19	D1
AC215T-15	480/590	3	0-460/575	20	24/24	D1
AC215T-18.5	480/590	3	0-460/575	25	27/27	D1

\* For dimensional details see page 38.

## FEATURES

- **Programmable:** Can be programmed using the front keypad, remote keypad, Modbus, or through your PC using the Techlink software.
- **Reversing:** Solid-state devices make reversing as simple as closing a contact.
- **Display:** 16 character backlit LCD display for programming, status, and diagnostics.
- **Braking:** DC injection braking is standard with a dynamic braking option when faster and repetitive stops are needed.
- **Carrier frequency:** Adjustable from 2.5 to 14kHz to help reduce the audible noise from the motor.
- **Automatic restart:** Can be programmed to automatically restart upon application of power.
- **Skip frequencies:** Two skip frequencies are available to lock out critical frequencies that cause mechanical resonance in the system.
- **Isolation:** Inputs and outputs are isolated and allow any speed reference signal to be accepted.
- **NEMA enclosure choices:** Choose either NEMA1, 4/12 or 4X.

The AC300 Series variable frequency, micro, V/Hz drive offers the widest range of voltages, power ratings, and enclosure types. These drives meet the toughest requirements from harsh environments to high torque loads. They are housed in a heavy-duty steel enclosure for solid mechanical protection and electrical shielding.

The AC300 has a 16 character backlit display for programming, drive status, and diagnostics. They have 21 isolated inputs and outputs including start, stop, 0-10 VDC input, 4-20 mA input, 10 VDC supply for an external potentiometer. Two open collector outputs, two analog outputs, three programmable inputs, two relay outputs, and RS485 (RXA, TXB).

The AC300 has over 55 programmable parameters that include: 4 or more ways to start and stop the motor, forward and/or reverse rotation, two adjustable acceleration and deceleration times (0.1 to 3600 seconds), DC injection braking time and voltage, maximum (120 Hz) and minimum frequency (0 Hz), current limit, motor overload, fixed and acceleration boost, slip compensation, 4 preset speeds, skip frequencies, and many more. These units can be programmed using the eight button keypad on the front of the drive enclosure, a remote keypad, a “point and click” Windows software (Techlink) that runs on a PC and works through the RS485, or with Modbus. The drives are shipped with default settings which shorten the time for setup requiring only a few adjustments in the program before the application can be off and running.

**OPTIONS:** In addition to the many standard features these units have they also have an optional dynamic brake card and resistor for those applications requiring quick repetitive stops, and a rugged NEMA 4 keypad mounting kit.

Part numbers and specifications on page 41.



HP (kW)	INPUT VOLTAGE (VAC)	INPUT PHASE	OUTPUT (Amps)	NEMA 1 MODEL	H x W x D (INCHES)	NEMA 4 & 12 MODEL	NEMA 4X MODEL	H x W x D (INCHES)
1/4 (0.20 kW)	240/120	1Ø	1.4	AC321S-0.2	7.50 x 4.70 x 3.33	AC331S-0.2	AC351S-0.2	7.88 X 6.12 X 3.63
1/2 (0.4 kW)	240/120	1Ø	2.2	AC321S-0.4	7.50 x 6.12 x 3.63	AC331S-0.4	AC351S-0.4	7.88 X 7.86 X 3.75
	240	1Ø	2.2	AC322S-0.4	7.50 x 4.70 x 3.63	AC332S-0.4	AC352S-0.4	7.88 X 6.12 X 4.35
	240/200	3Ø	2.2/2.5	AC322T-0.4	7.50 x 4.70 x 3.63	AC332T-0.4	AC352T-0.4	7.88 X 6.12 X 4.35
1 (0.75 kW)	240/120	1Ø	4.0	AC321S-0.75	7.50 x 6.12 x 4.22	AC331S-0.75	AC351S-0.75	7.88 X 7.86 X 4.90
	240	1Ø	4.0	AC322S-0.75	7.50 x 4.70 x 4.33	AC332S-0.75	AC352S-0.75	7.88 X 6.12 X 4.35
	240/200	3Ø	4.0/4.6	AC322T-0.75	7.50 x 4.70 x 4.33	AC332T-0.75	AC352T-0.75	7.88 X 6.12 X 4.35
	480/400	3Ø	2.0/2.3	AC324T-0.75	7.50 x 4.70 x 3.63	AC334T-0.75	AC354T-0.75	7.88 X 6.12 X 4.35
	590	3Ø	1.6	AC325T-0.75	7.50 x 4.70 x 3.63	AC335T-0.75	AC355T-0.75	7.88 X 6.12 X 4.35
1.5 (1.1 kW)	240/120	1Ø	5.2	AC321S-1.1	7.50 x 6.12 x 4.22	AC331S-1.1	AC351S-1.1	7.88 X 7.86 x 4.90
	240	1Ø	5.2	AC322S-1.1	7.50 x 6.12 x 4.22	AC332S-1.1	AC352S-1.1	7.88 X 7.86 x 4.90
	240/200	3Ø	5.2/6.0	AC322T-1.1	7.50 x 4.70 x 4.33	AC332T-1.1	AC352T-1.1	7.88 x 6.12 x 5.25
2 (1.5 kW)	240	1Ø	6.8	AC322S-1.5	7.50 x 6.12 x 5.12	AC332S-1.5	AC352S-1.5	7.88 x 7.86 x 4.90
	240/200	3Ø	6.8/7.8	AC322T-1.5	7.50 x 6.12 x 5.12	AC332T-1.5	AC352T-1.5	7.88 x 7.86 x 4.90
	480/400	3Ø	3.4/3.9	AC324T-1.5	7.50 x 6.12 x 4.22	AC334T-1.5	AC354T-1.5	7.88 x 7.86 x 4.90
	590	3Ø	2.7	AC325T-1.5	7.50 x 6.12 x 4.22	AC335T-1.5	AC355T-1.5	7.88 x 7.86 x 4.90
3 (2.2 kW)	240	1Ø	9.6	AC322S-2.2	7.50 x 6.12 x 5.12	AC332S-2.2	AC352S-2.2	7.88 x 7.86 x 5.90
	240/200	3Ø	9.6/11.0	AC322T-2.2	7.50 x 6.12 x 5.12	AC332T-2.2	AC352T-2.2	7.88 x 7.86 x 5.90
	480/400	3Ø	4.8/5.5	AC324T-2.2	7.50 x 6.12 x 5.12	AC334T-2.2	AC354T-2.2	7.88 x 7.86 x 4.90
	590	3Ø	3.9	AC325T-2.2	7.50 x 6.12 x 5.12	AC335T-2.2	AC355T-2.2	7.88 x 7.86 x 4.90
5 (3.7 kW)	240/200	3Ø	15.2/17.5	AC322T-3.7	7.88 x 7.86 x 5.94	AC332T-3.7	AC352T-3.7	9.75 x 10.26 x 7.20
	480/400	3Ø	7.6/8.7	AC324T-3.7	7.50 x 6.12 x 5.12	AC334T-3.7	AC354T-3.7	7.88 x 7.86 x 5.90
	590	3Ø	6.1	AC325T-3.7	7.50 x 7.86 x 5.94	AC335T-3.7	AC355T-3.7	7.88 x 7.86 x 5.90
7.5 (5.5 kW)	240/200	3Ø	22/25	AC322T-5.5	9.38 x 7.86 x 6.84	AC332T-5.5	AC352T-5.5	11.75 x 10.26 x 8.35
	480/400	3Ø	11/12.6	AC324T-5.5	9.38 x 7.86 x 6.25	AC334T-5.5	AC354T-5.5	9.75 x 10.26 x 7.20
	590	3Ø	9	AC325T-5.5	9.38 x 7.86 x 6.25	AC335T-5.5	AC355T-5.5	9.75 x 10.26 x 7.20
10 (7.5 kW)	240/200	3Ø	28/32	AC322T-7.5	11.25 x 7.86 x 6.84	AC332T-7.5	AC352T-7.5	13.75 x 10.26 x 8.35
	480/400	3Ø	14/16	AC324T-7.5	9.38 x 7.86 x 6.84	AC334T-7.5	AC354T-7.5	11.75 x 10.26 x 8.35
	590	3Ø	11	AC325T-7.5	9.38 x 7.86 x 7.40	AC335T-7.5	AC355T-7.5	11.75 x 10.26 x 8.35
15 (11 kW)	240/200	3Ø	42/48	AC322T-11	12.75 x 7.86 x 6.84	AC332T-11	AC352T-11	15.75 x 10.26 x 8.35
	480/400	3Ø	21/24	AC324T-11	11.25 x 7.86 x 6.84	AC334T-11	AC354T-11	13.75 x 10.26 x 8.35
	590	3Ø	17	AC325T-11	12.75 x 7.86 x 6.64	AC335T-11	AC355T-11	13.75 x 10.26 x 8.35
20 (15 kW)	240/200	3Ø	54/62	AC322T-15	12.75 x 10.26 x 7.74	AC342T-15	————	15.75 x 10.26 x 8.35
	480/400	3Ø	27/31	AC324T-15	12.75 x 7.86 x 6.84	AC334T-15	AC354T-15	15.75 x 10.26 x 8.35
	590	3Ø	22	AC325T-15	12.75 x 7.86 x 7.40	AC335T-15	AC355T-15	15.75 x 10.26 x 8.35
25 (18.5 kW)	240/200	3Ø	68/78	AC322T-18.5	15.75 x 10.26 x 8.35	————	————	————
	480/400	3Ø	34/39	AC324T-18.5	12.75 x 10.26 x 7.74	AC344T-18.5	————	15.75 x 10.26 x 8.35
	590	3Ø	27	AC325T-18.5	12.75 x 10.26 x 7.74	AC345T-18.5	————	15.75 x 10.26 x 8.35
30 (22 kW)	240/200	3Ø	80/92	AC322T-22	15.75 x 10.26 x 8.35	————	————	————
	480/400	3Ø	40/46	AC324T-22	12.75 x 10.26 x 7.74	AC344T-22	————	15.75 x 10.26 x 8.35
	590	3Ø	32	AC325T-22	12.75 x 10.26 x 8.25	AC345T-22	————	15.75 x 10.26 x 8.35
40 (30 kW)	480/400	3Ø	52/60	AC324T-30	15.75 x 10.26 x 8.35	————	————	————
	590	3Ø	41	AC325T-30	15.75 x 10.26 x 8.35	————	————	————
50 (37 kW)	480/400	3Ø	65/75	AC324T-37	19.75 x 10.26 x 8.55	————	————	————
	590	3Ø	52	AC325T-37	19.75 x 10.26 x 8.55	————	————	————
60 (45 kW)	480/400	3Ø	77/80	AC324T-45	19.75 x 10.26 x 8.55	————	————	————
	590	3Ø	62	AC325T-45	19.75 x 10.26 x 8.55	————	————	————

Note: Model numbers with a "3" as a second digit (AC33) are suitable for NEMA 4 and NEMA 12 applications. Models with a "4" as a second digit (AC34) are suitable for NEMA 12 applications.

Add "P" suffix for remote keyboard (This option can be combined with only one (1) of the three (3) options listed below when ordering).

Add "H" suffix for an additional Form C relay board.

Add "J" suffix for a dynamic braking board (for units 5 HP and below only). Brake resistors are purchased separately.

Add "K" suffix for a dynamic braking and Form C relay board (for units above 5 HP only). Brake resistors are purchased separately.

## Digital Controls

MODEL	AC LINE VOLTAGE	AC LINE POWER	ACCEPTABLE FEEDBACK SOURCES	ANALOG OUTPUT VOLTAGE RANGE	POWER SUPPLY VOLTAGE FOR FEEDBACK DEVICES	SPEED REGULATION	FEEDBACK FREQUENCY RANGE
DLC600	115 or 230 VAC $\pm 10\%$ 50/60 HZ, Single Phase	5.5 watts nominally	<ul style="list-style-type: none"> <li>•Hall Effect Sensor**</li> <li>•Electromagnetic Pickup</li> <li>•5 or 12 VDC NPN-type encoder or proximity switch**</li> <li>•Encoder**</li> </ul>	0 to +10 VDC	+5 VDC or +12 VDC @ 10 mA	0.05%	10 to 3000Hz*

\* System speed range may be limited by other factors, such as motor type, drive type, feedback resolution, etc.

\*\* NPN-type feedback devices should have a built-in pull-up resistor or have a pull-up resistor added externally.

F

### DIMENSIONS

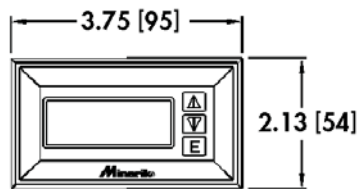
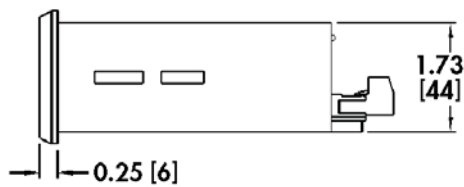

Depth: 5.38 [137]

All dimensions in inches [millimeters]

### FEATURES

- **Excellent Speed Regulation:** 0.05% speed regulation of set speed provides for tight control throughout a 200:1 speed range.
- **Pushbutton Programming:** Three front panel pushbuttons provide quick and easy programming.
- **4-Digit LED Display:** Red 0.5 inch (13 mm) wide digits for good visibility.
- **Programmable Decimal Point:** Makes specific application readouts easy.
- **Inhibit Terminal:** A low voltage, dry contact closure on the inhibit terminal will reduce the output to zero.
- **Selectable Feedback Devices:** Controls accept magnetic pickup, hall effect, inductive proximity sensor or encoder input.
- **+ 5 VDC or + 12 VDC (10 mA) Power Supply:** Provided to power feedback devices.

Minarik's DLC600 precisely controls your closed loop application speed. The DLC600's dual voltage capability allows it to replace Minarik's older DLC products. An encoder or proximity switch, hall effect sensor, or electromagnetic pickup can provide the necessary feedback. Any engineering units, from revolutions per minute, to widgets per day can be used to display and program the speed. The large 4-digit LED display allows you to easily see exactly what speed you are running. The analog output from the drive is isolated and can be used with almost all Minarik Drives. The PK24 Series (page 44) encoders can be used with a 507-XX-XXX (page 30) motor to complete your closed loop system. When it comes to low-cost closed loop control, the DLC600 is your solution.



DLC600

MODEL	AC LINE VOLTAGE	AC LINE POWER	ACCEPTABLE FEEDBACK SOURCES	FEEDBACK FREQUENCY RANGE	POWER SUPPLY VOLTAGE FOR FEEDBACK DEVICES
VT8-D230AC	115/230 VAC ±10% 50/60 Hz, Single Phase	5.5 watts nominally	<ul style="list-style-type: none"> <li>•5 or 12 VDC NPN-type encoder or proximity switch**</li> <li>•Hall effect sensor**</li> <li>•Electromagnetic Pickup</li> <li>•Encoder**</li> </ul>	0 - 20,000 Hz	+5 VDC or +12 VDC

\*\* NPN-type feedback devices should have a built in pull-up resistor or have a pull-up resistor added externally.

F

Minarik's VT8 Series is the choice when it comes to digital tachometers.

The VT8 Series provides a simple and accurate read-out for any rotating shaft that has an optical encoder, magnetic pickup, or anything else that can generate a frequency related to what you wish to measure.

There are four modes to choose from: tachometer mode for speed in any engineering unit, time in process for indicating the duration of an application, the inverse of speed (such as minutes per revolution), and basic totalizer for counting the frequency of the speed sensor.

The VT8 Series can be used with the PK24 Series (page 44) encoders and 507-XX-XXX (page 30) motors.

The VT8-D230AC replaces previous versions of the VT Series.



VT8-D230AC

### DIMENSIONS

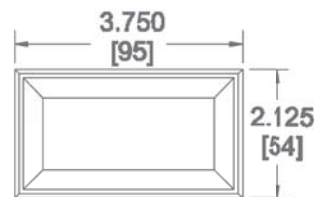
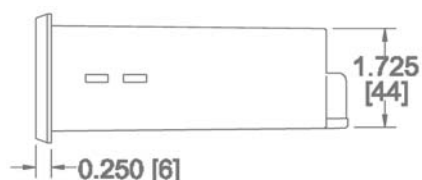

Depth: 4.53 [115]

All dimensions in inches [millimeters]

### FEATURES

- **Four Operating Modes:** Displays 1) speed of application or multiple of it 2) time in process indicating duration of application 3) the inverse speed (i.e., minutes per revolution) 4) number of counts received from feedback device.
- **Selectable Feedback Devices:** Accepts magnetic pickup, hall effect, inductive proximity sensor or encoder input.
- **+5 VDC (50mA) or +12 VDC (25mA) power supply:** Provided to power feedback device.
- **Wide Frequency Range:** Accepts 0 - 20,000 Hz from feedback device.
- **Easy to Read Display:** 4-digit LED display is 0.7" (17.5 mm).

## PK SERIES DIMENSIONS

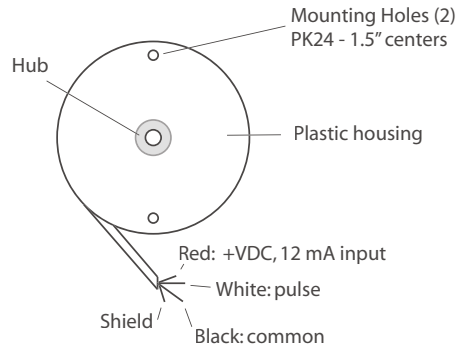
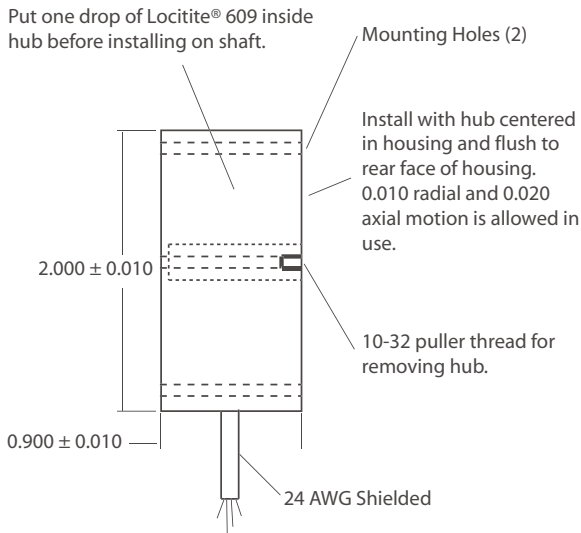

Note: All dimensions are in inches.  
Specification data subject to change without notice.

### SPECIFICATIONS

#### Electrical Input

Voltage	5 VDC	12 VDC
Current	12 mA	12 mA
Regulation	±10%	±10%

#### Electrical Output

Wave shape	Square wave nominal
Rise Time	Less than 10 Microseconds
Current	Sink 0.8 Milliamperes @ 0.4 Volts (NPN)
Pulses per revolution	2 to 64 (specify)

#### Mechanical

Shaft speed	20000 RPM maximum
Rotation	Either direction
Hub bore	0.187" PK24
Housing	Delrin (black)
Cable	3-conductor 24 AWG shielded (with drain)
Weight	2 ounces

### PART NUMBER SYSTEM

## PK24-XX-YYV

XX = Pulses Per Revolution (PPR): 30, 60

YY = Input Voltage (volts DC): 5, 12  
(Other voltages may be available. Consult Factory)

Example: PK24-30-5V means 30 PPR  
and requires a 5 VDC power supply

The PK24 Series encoders easily mount on the back of the 507-XX-XXX (page 30) motors. These encoders output a single channel square wave to provide more accurate speed indication and regulation when used with digital accessories. Their hollow shaft design allows for easy installation without tedious alignment procedures. The accuracy and ease of installation make the PK24 Series the ideal choice for your encoder feedback. The PK24 Series also works great with DLC600 (pg 42) and VT8-D230AC (pg 43)

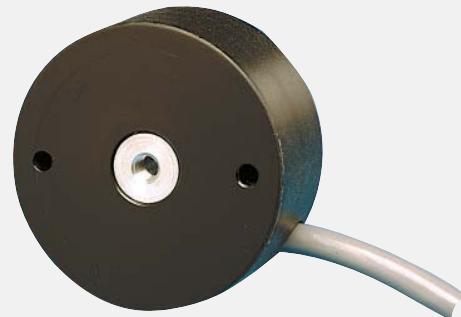

PK24 Series

### PCM4 Isolation Card (Open Chassis)

The PCM4 card is a compact and cost-effective solution for process control applications. Powered by 115 or 230 VAC, the PCM4 uses Burr Brown® Technology to isolate and condition incoming DC voltage signals from process controllers, motors, transducers, micro-processors or any signal. Typically, the output of the PCM4 connects to the input of a motor drive; hence, incompatible devices safely couple to yield a higher level of automation. Integrating this isolation card allows drives to follow any non-isolated external voltage or current analog process control signal.

Dip-switch selectable, the PCM4 can follow any input voltage signal, grounded or ungrounded, from -250 to +250 VDC, and any input current signal from 1 to 50 mA. In response to the input, the PCM4 outputs an isolated bipolar signal from -12 to +12 VDC @ 10 mA, 0.01% linearity yields precise results. High resolution multi-turn pots lets users scale the output to within millivolts of the input or any desired proportion within the range of the output. Users may elect to control devices in manual mode using normal potentiometer operation rather than from an external signal input.

The most common use for the PCM4 is to take an unisolated voltage signal from a PLC and isolate the signal and feed it into the drive. The PCM4 can also take a 4-20 mA signal and convert it into an isolated voltage signal for the drive to follow. The PCM4 also works great when accepting a motor armature voltage and scaling isolating it into a drive in a leader-follower system.



PCM4

### 200-0386A Limit Switch Logic Board (Open Chassis)

Comparable to a mini-PLC, the 200-0386A logic board provides compact intelligence and a high degree of automation when combined with a regenerative drive in four-quadrant applications. Switching logic board modules interface regenerative variable-speed drives with pushbuttons, limit switches, foot switches, or programmable controls to produce a low-cost system. The logic module accepts commands from dry contact mechanical closures, current-sinking open-collectors, and TTL logic devices.

After wiring and selecting the dip-switch configuration, the 200-0386A operates in one of nine modes, including automatic cycling, single cycle, half cycle, jog and more. The cycle applications are ideal for applications with limit switches. No programming is required!

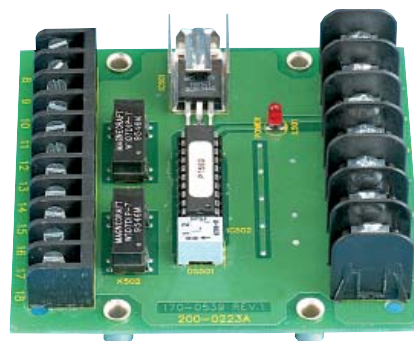

200-0386A

### SPEED DIALS AND KNOBS

STOCK NO.	DESCRIPTION	TECHNICAL DATA	MODEL USAGE
110-0038	Rectangle Dial Plate	1.75" W x 1.5" H w/0.375" Hole	All chassis drives
140-0009	Knob	1" OD w/0.25" Hole	All chassis drives

### HEAT SINKS

STOCK NO.	DESCRIPTION	TECHNICAL DATA	MODEL USAGE
223-0159	Heat Sink	4.40" x 3.00" x 0.70" aluminum	MM chassis controls
223-0174	Heat Sink	7.78" x 6.00" x 0.89" aluminum	NEMA 1 cased controls
223-0235	Heat Sink	9.20" x 6.90" x 1.00" aluminum	RG500 Series chassis controls
223-0271	Heat Sink	9.78" x 6.90" x 1.00" aluminum	XL controls

### INHIBIT PLUGS

STOCK NO.	DESCRIPTION	TECHNICAL DATA	MODEL USAGE
201-0024	Inhibit plug	18"	All drives with inhibit terminal
201-0079	Inhibit plug	36"	All drives with inhibit terminal

### SERIAL CABLES

STOCK NO.	DESCRIPTION	TECHNICAL DATA	MODEL USAGE
134-0046	Serial Cable	DB9 male to female	DC500N-4Q

### BRAKE RESISTORS

STOCK NO.	DESCRIPTION	TECHNICAL DATA	MODEL USAGE
032-0060	Brake Resistor	10 $\Omega$ 40W (fast braking)	1 HP and less
032-0062	Brake Resistor	20 $\Omega$ 40W (medium/fast braking)	2 HP and less
032-0076	Brake Resistor	40 $\Omega$ 40W (medium braking)	2 HP and less
035-0007	Left-side bracket	Mounting vertically	032-0060, 032-0062, 032-0076
035-0008	Right-side bracket	Mounting vertically	032-0060, 032-0062, 032-0076



## KITS AND COVERS

STOCK NO.	DESCRIPTION	TECHNICAL DATA	MODEL USAGE
155-0075	Clear NEMA4 cover	Polysilicone	VT8
201-0191	Bezel and lens	Polycarbonate, red	DLC600
202-0014	Mounting kit	2 brackets, 4 screws	DLC600, VT8-D230AC
220-0048	Bezel and lens	Polycarbonate, red	VT8-115/230
220-0049	Blank bezel and lens	Polycarbonate, red	VT8-115/230
220-0051	Bezel and lens	Polycarbonate, red	DLC300/400

F

## EMI/RFI LINE FILTERS

STOCK NO.	DESCRIPTION	TECHNICAL DATA	MODEL USAGE
6EP1	Reduces control noise	Meets VDE-A, FCC-B	XL3025
6VDK1	Reduces control noise	Meets FCC-A, FCC-B, VDE-A	MM's and RG's to 1/4 HP
6VSK1	Reduces control noise	Meets FCC-A	XL3025
6VV1	Reduces incoming noise	Meets EN55011, EN50082-1, EN60204-1	MM's and PCM's to 1/4 HP
10EP1	Reduces control noise	Meets FCC-A	XL's to 1 HP
15ET1	Reduces control noise	Meets FCC-A, FCC-B	XL's to 2 HP
20VDK1	Reduces control noise	Meets FCC-A, FCC-B, VDE-A	MM's and RG's 1/4 HP and up
20VV1	Reduces incoming noise	Meets EN55011, EN50082-1, EN60204-1	MM's and PCM's 1/4 HP and up
5VR1	Reduces incoming noise	Meets EN55011, EN50082-1, EN60204-1	RG's up to 1/4 HP
20VR1	Reduces incoming noise	Meets EN55011, EN50082-1, EN60204-1	RG's 1/4 HP and up

## CE FILTERS

STOCK NO.	DESCRIPTION	TECHNICAL DATA	MODEL USAGE
CE4MM	Reduces control noise	Meets EN55011, EN50082-1, EN60204-1	4 Amp, DC output CE filters for MM Series
CE20MM	Reduces control noise	Meets EN55011, EN50082-1, EN60204-1	20 Amp, DC output CE filters for MM Series
CE4RG	Reduces control noise	Meets EN55011, EN50082-1, EN60204-1	4 Amp, DC output CE filters for RG Series
CE20RG	Reduces control noise	Meets EN55011, EN50082-1, EN60204-1	20 Amp, DC output CE filters for RG Series
CE24PWM	Reduces incoming noise	Meets EN55011, EN50082-1, EN60204-1	24 Amp, AC input CE filters for PWM Series
CE04XL	Reduces incoming noise	Meets EN55014, EN50082-1, EN60204-1	4 Amp, AC input CE filters for XL Series
CE15XL	Reduces incoming noise	Meets EN55014, EN50082-1, EN60204-1	15 Amp, AC input CE filters for XL Series

## DYNAMIC BRAKING

STOCK NO.	DESCRIPTION	TECHNICAL DATA	MODEL USAGE
840-100	Dynamic braking resistor module	1/4 - 1/2 HP, 208 to 230 VAC motor voltage	ACM100 & AC200 SERIES
840-101	Dynamic braking resistor module	1 - 1.5 HP, 208 to 230 VAC motor voltage	ACM100 & AC200 SERIES
840-102	Dynamic braking resistor module	2 - 3 HP, 208 to 230 VAC motor voltage	ACM100 & AC200 SERIES
840-103	Dynamic braking resistor module	5 HP, 208 to 230 VAC motor voltage	ACM100 & AC200 SERIES
840-104	Dynamic braking resistor module	7.5 HP, 208 to 230 VAC motor voltage	AC200 SERIES
840-105	Dynamic braking resistor module	10 HP, 208 to 230 VAC motor voltage	AC200 SERIES
840-106	Dynamic braking resistor module	1/4 - 1/2 HP, 400 to 480 VAC motor voltage	ACM100 & AC200 SERIES
840-107	Dynamic braking resistor module	1 - 1.5 HP, 400 to 480 VAC motor voltage	ACM100 & AC200 SERIES
840-108	Dynamic braking resistor module	2 - 3 HP, 400 to 480 VAC motor voltage	ACM100 & AC200 SERIES
840-109	Dynamic braking resistor module	5 HP, 400 to 480 VAC motor voltage	ACM100 & AC200 SERIES
840-110	Dynamic braking resistor module	7.5 HP, 400 to 480 VAC motor voltage	AC200 SERIES
840-111	Dynamic braking resistor module	10 HP, 400 to 480 VAC motor voltage	AC200 SERIES
840-112	Dynamic braking resistor module	1 - 1.5 HP, 480 to 590 VAC motor voltage	ACM100 & AC200 SERIES
840-113	Dynamic braking resistor module	2 - 3 HP, 480 to 590 VAC motor voltage	ACM100 & AC200 SERIES
840-114	Dynamic braking resistor module	5 HP, 480 to 590 VAC motor voltage	ACM100 & AC200 SERIES
840-115	Dynamic braking resistor module	7.5 HP, 480 to 590 VAC motor voltage	AC200 SERIES
840-116	Dynamic braking resistor module	10 HP, 480 to 590 VAC motor voltage	AC200 SERIES
840-117	Dynamic braking module*	15 - 25 HP, 208 to 230 VAC motor voltage	AC200 SERIES
840-118	Dynamic braking module*	15 - 25 HP, 400 to 480 VAC motor voltage	AC200 SERIES
840-119	Dynamic braking module*	15 - 25 HP, 480 to 590 VAC motor voltage	AC200 SERIES
841-030**	Dynamic braking kit * (field installation)	1/2 - 3 HP @ 200/240 VAC, 1 - 3 HP @ 400/480 VAC & 1 - 5 HP @ 480/590 VAC	AC300 SERIES
841-031**	Dynamic braking kit * (field installation)	5 HP @ 200/240 VAC and 5 HP @ 400/480 VAC	AC300 SERIES
841-032**	Dynamic braking & Form C relay kit*	7.5 - 30 HP @ 200/240 VAC, 10 - 60 HP @ 400/480 VAC & 10-60 HP @ 480/590 VAC	AC300 SERIES
841-033**	Dynamic braking & Form C relay kit*	7.5 HP @ 400/480 VAC & 7.5 HP @ 480/590 VAC	AC300 SERIES
841-100	Dynamic braking resistors	1.5 HP @ 200/240 VAC & 1 HP @ 480/590 VAC	AC300 SERIES
841-101	Dynamic braking resistors	1 - 1.5 HP @ 200/240 VAC, 1 HP @ 400/480 VAC & 2 HP @ 480/590 VAC	AC300 SERIES
841-102	Dynamic braking resistors	2 HP @ 200/240 VAC, 2 HP @ 400/480 VAC	AC300 SERIES
841-103	Dynamic braking resistors	3 HP @ 480/590 VAC	AC300 SERIES
841-104	Dynamic braking resistors	3 HP @ 200/240 VAC, 3 HP @ 400/480 VAC & 5 HP @ 480/590 VAC	AC300 SERIES
841-105	Dynamic braking resistors	5 HP @ 200/240 VAC & 5 HP @ 400/480 VAC	AC300 SERIES
841-106	Dynamic braking resistors	7.5 - 10 HP @ 200/240 VAC & 7.5 - 10 HP @ 400/480 VAC	AC300 SERIES
841-107	Dynamic braking resistors	7.5 - 10 HP @ 480/590 VAC	AC300 SERIES
841-108	Dynamic braking resistors	15 - 20 HP @ 200/240 VAC & 15 - 20 HP @ 400/480 VAC	AC200, 300 SERIES
841-109	Dynamic braking resistors	15 - 20 HP @ 480/590 VAC	AC200, 300 SERIES
841-110	Dynamic braking resistors	25 HP @ 200/240 VAC & 25 - 30 HP @ 400/480 VAC	AC200, 300 SERIES
841-111	Dynamic braking resistors	25 - 30 HP @ 480/590 VAC	AC200, 300 SERIES
841-112	Dynamic braking resistors	40 HP @ 400/480 VAC	AC300 SERIES
841-113	Dynamic braking resistors	40 HP @ 480/590 VAC	AC300 SERIES
841-114	Dynamic braking resistors	50 - 60 HP @ 400/480 VAC	AC300 SERIES
841-115	Dynamic braking resistors	50 - 60 HP @ 480/590 VAC	AC300 SERIES

\* The "Dynamic Braking Resistors" listed above need to be ordered separately with these options.

\*\* It is recommended when ordering a new drive that these options be installed at the factory. Refer to the suffix information on the bottom of page 41 for ordering information.

### REMOTE KEYPAD OPTIONS

STOCK NO.	DESCRIPTION	TECHNICAL DATA	MODEL USAGE
840-004	Remote keypad w/ gasket	8 foot connecting cable, NEMA 4X rated	AC200 SERIES
840-010	Remote keypad w/ gasket	8 foot connecting cable, NEMA 4X rated	ACM100 SERIES
841-006**	Remote keypad kit (field installation)	10 foot cable and NEMA 4 remote keypad	AC300 NEMA 1 models only

F

### EPM OPTIONS

STOCK NO.	DESCRIPTION	TECHNICAL DATA	MODEL USAGE
840-005	EPM programmer	4.13 H x 6.00 W, battery operated	ACM100 & AC200 SERIES
840-006	EPM modules bulk pack	10 electronic programming modules	ACM100 & AC200 SERIES

### HIGH FREQUENCY OUTPUT

STOCK NO.	DESCRIPTION	TECHNICAL DATA	MODEL USAGE
"V" Suffix	High frequency output option	Up to 1000 Hz output to motor	AC200 SERIES

\*\* It is recommended when ordering a new drive that these options be installed at the factory.



## Low Voltage Drive Comparisons

Model Numbers	2007 List Price	Power In / Power Out						Standard Features										Approvals		LEDs			Packaging			
		Input Voltage (VAC) 50/60 Hertz	Input Voltage (VDC)	Output Voltage Range (VDC) <sup>3</sup>	Max Continuous Current (ADC)	Max Continuous Current with Additional Heatsink (ADC)	Peak Output Current 1 Minute (ADC)	IR Compensation	Current Limit	Regen Current Limit	Max Speed	Min Speed	Accel	Decel	Combined Acc/Dec	Four Quadrant Reversing	Regen Brake to Stop	Coast to Stop	Microprocessor Based (Custom Programming Available)	UL (Recognized or Listed)	CE	Power LED	Diagnostic LED	Current Limit LED	Temp Range (°C)	NEMA Enclosure <sup>4</sup>
DC1.5-12	\$70		8-16	0-15	1	1.5		✓			✓							✓							10 - 40	U
DC1.5-24	\$70		16-32	0-31	1	1.5		✓			✓							✓							10 - 40	U
DC16-12/24	\$207		10-32	0-30	16	25	✓	✓		✓	✓	✓	✓		✓	✓	✓	✓	✓	✓	✓	✓	✓	✓	10 - 40	U
DC30-12/24-4Q	\$160		8-32	0-28	15	30	✓	✓		✓	✓	✓	✓		✓	✓	✓	✓	✓	✓	✓	✓	✓	✓	10-40	U
DC60-12/24	\$222		10-32	0-32	60		✓	✓		✓	✓	✓	✓		✓	✓	✓	✓	✓	✓	✓	✓	✓	✓	10 - 40	U
DC60-36/48	\$222		32-50	0-48	60		✓	✓		✓	✓	✓	✓		✓	✓	✓	✓	✓	✓	✓	✓	✓	✓	10 - 40	U
DC240-12/24-4Q	\$443		10-30	0-30	100	240	✓	✓		✓	✓	✓	✓		✓	✓	✓	✓	✓	✓	✓	✓	✓	✓	10 - 40	U
DC250-36/48-4Q	\$443		20-62	0-62	120	250	✓	✓		✓	✓	✓	✓		✓	✓	✓	✓	✓	✓	✓	✓	✓	✓	10 - 40	U
DC500N-4Q-36/48	\$1,759		36-48	0-48	200	500	✓	✓		✓	✓	✓	✓		✓	✓	✓	✓	✓	✓	✓	✓	✓	✓	10 - 40	1
LV02-24AC	\$128	8-24	10-36	0-22	2		✓	✓		✓							✓								10 - 40	U
LV02-24DC	\$128		10-36	0-22	2		✓	✓		✓							✓								10 - 40	U

NEMA Enclosures<sup>4</sup>  
 U = Chassis  
 1 = NEMA 1

✓<sup>1</sup>: Programmed by RS232  
 ✓<sup>2</sup>: Requires a Super motor  
 X<sup>3</sup>: Output voltage is never greater than input voltage



AC Drive Comparisons

Model Numbers	2007 List Price	Power In/Out					Standard Features												Approvals		LEDs and Fusing				Package	NEMA Enclosure <sup>3</sup>
		Input Voltage Single Phase	Nominal Output Voltage	Maximum Continuous Output Current (Amps)	Max Horsepower	Max Speed Pot	Min Speed Pot	Separate Acc/Dec Pots	Slip Compensation	Boost	Torque/Current Limit	Adjustable Carrier Frequency	Voltage Doubler	Enable Switch	Isolated Front End	DC Injection Braking	Reversing	UL (Recognized or Listed)	CE	Torque LED	Power LED	Fault LED	Line Fuses	Temp Range (°C)		
TA10-D <sup>1</sup>	\$157	115 or 230 VAC	0-115 / 0-230	10	1 / 2	✓	✓																		10-55	U
VFD02-115AC	\$157	115 VAC	0-115 V	2.4	1/4	✓	✓	✓	✓	✓	✓	✓	✓	✓	✓	✓	✓	✓	✓	✓	✓	✓	✓	✓	10-40	U
VFD02-230AC	\$157	230 VAC	0-230 V <sup>2</sup>	2.4	1/2	✓	✓	✓	✓	✓	✓	✓	✓	✓	✓	✓	✓	✓	✓	✓	✓	✓	✓	✓	10-40	U
VFD02-D230AC	\$190	115 or 230 VAC	0-230 V <sup>2</sup>	2.4	1/2	✓	✓	✓	✓	✓	✓	✓	✓	✓	✓	✓	✓	✓	✓	✓	✓	✓	✓	✓	10-40	U
VFD04-115VAC	\$196	115 VAC	0-115 V	4	1/2	✓	✓	✓	✓	✓	✓	✓	✓	✓	✓	✓	✓	✓	✓	✓	✓	✓	✓	✓	10-40	U
VFD04-230AC	\$202	230 VAC	0-230 V <sup>2</sup>	4	1	✓	✓	✓	✓	✓	✓	✓	✓	✓	✓	✓	✓	✓	✓	✓	✓	✓	✓	✓	10-40	U
VFD04-D230AC	\$245	115 or 230 VAC	0-230 V <sup>2</sup>	4	1	✓	✓	✓	✓	✓	✓	✓	✓	✓	✓	✓	✓	✓	✓	✓	✓	✓	✓	✓	10-40	U
200-0422 (Added to VFD01-VFD04)	\$46																✓								10-40	U
VFD05-D230-PCM	\$292	115 or 230 VAC	0-230 V <sup>2</sup>	5	1.5	✓	✓	✓	✓	✓	✓	✓	✓	✓	✓	✓	✓	✓	✓	✓	✓	✓	✓	✓	10-40	U
VFDA4X04-D230-PCM	\$449	115 or 230 VAC	0-230 V <sup>2</sup>	4	1	✓	✓	✓	✓	✓	✓	✓	✓	✓	✓	✓	✓	✓	✓	✓	✓	✓	✓	✓	10-40	A4X
VFDFA4X04-D230-PCM	\$486	115 or 230 VAC	0-230 V <sup>2</sup>	4	1	✓	✓	✓	✓	✓	✓	✓	✓	✓	✓	✓	✓	✓	✓	✓	✓	✓	✓	✓	10-40	F4X
VFDPA4X04-D230-PCM	\$346	115 or 230 VAC	0-230 V <sup>2</sup>	4	1	✓	✓	✓	✓	✓	✓	✓	✓	✓	✓	✓	✓	✓	✓	✓	✓	✓	✓	✓	10-40	P4X
VFDSA4X05-D230-PCM	\$504	115 or 230 VAC	0-230 V <sup>2</sup>	5	1.5	✓	✓	✓	✓	✓	✓	✓	✓	✓	✓	✓	✓	✓	✓	✓	✓	✓	✓	✓	10-40	S4X

<sup>1</sup>Single Phase Motors Only  
<sup>2</sup>230 VAC Motor Only  
<sup>3</sup>PE = Pending

NEMA Enclosures<sup>3</sup>  
 U = Chassis  
 A4X = NEMA 4X (Aluminum)  
 F4X = NEMA 4X (Food Grade)  
 P4X = NEMA 4X (Plexig)  
 S4X = NEMA 4X (Steel)

## Dimensional Drawings

**G**

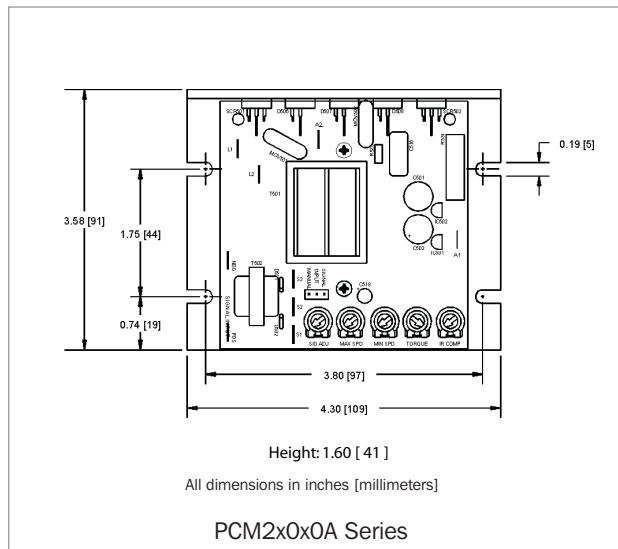
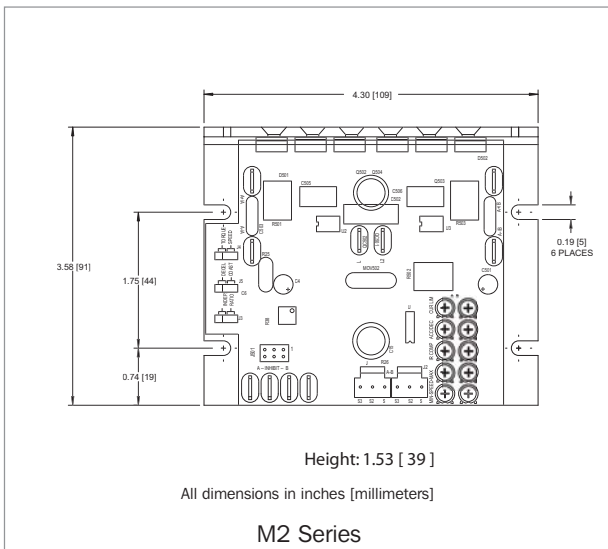
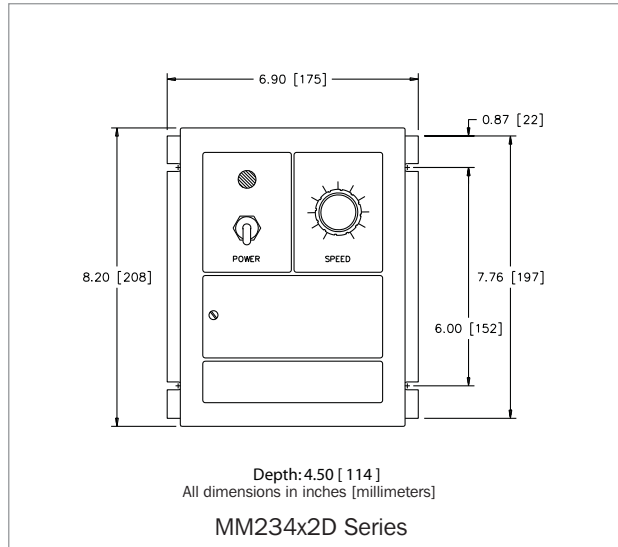
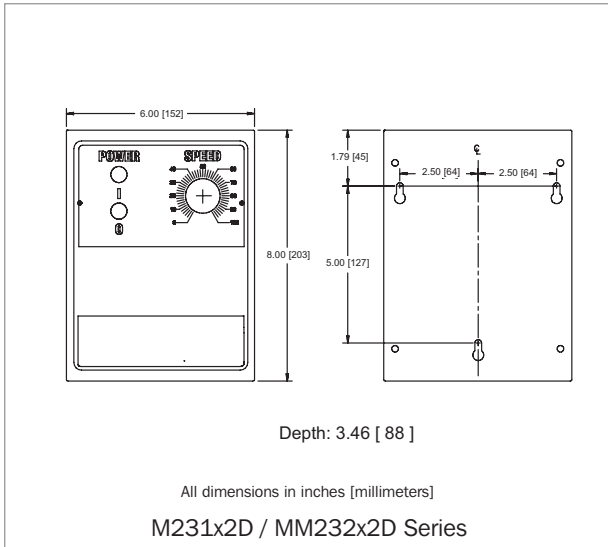
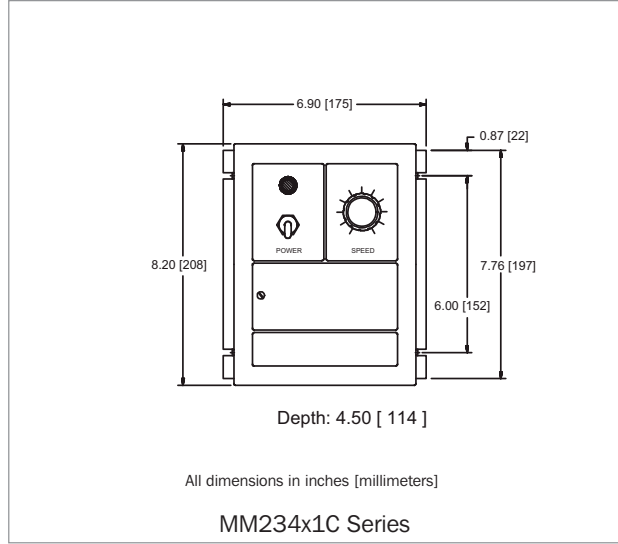
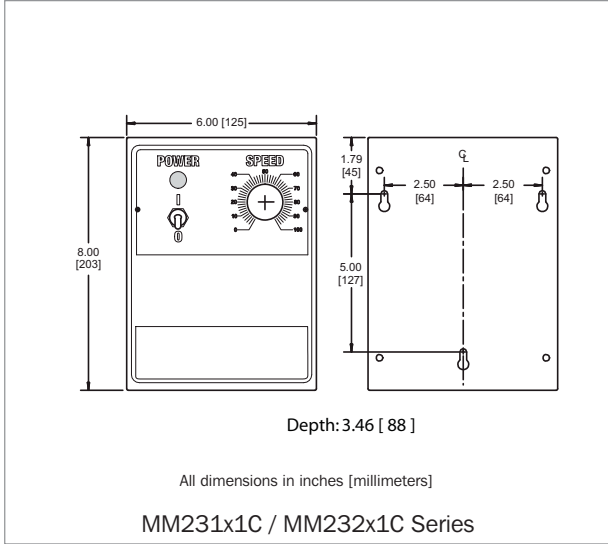



## Dimensional Drawings

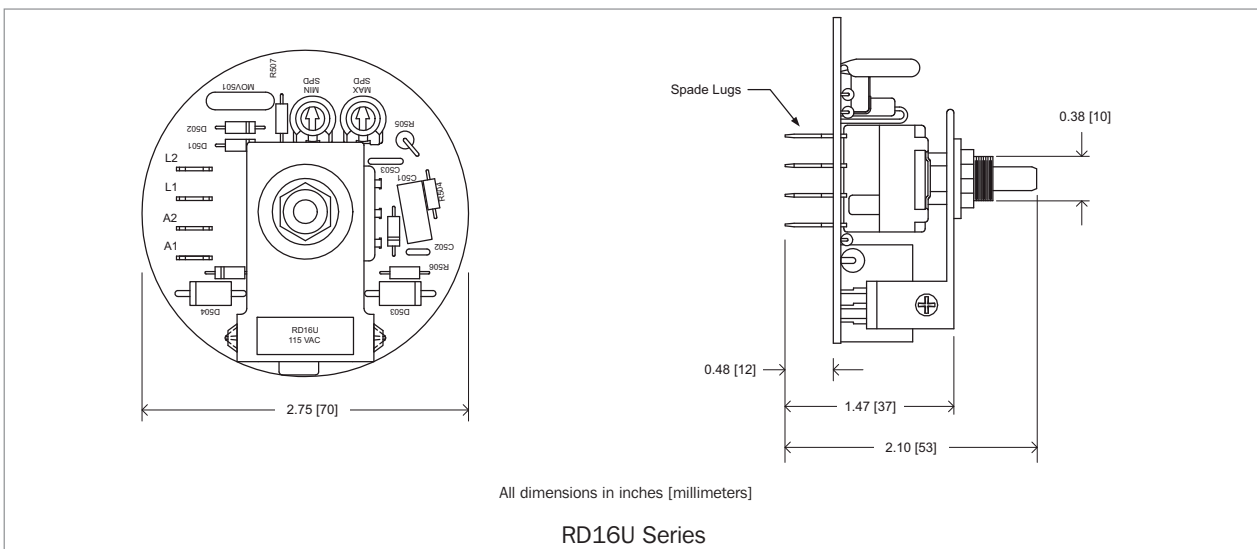
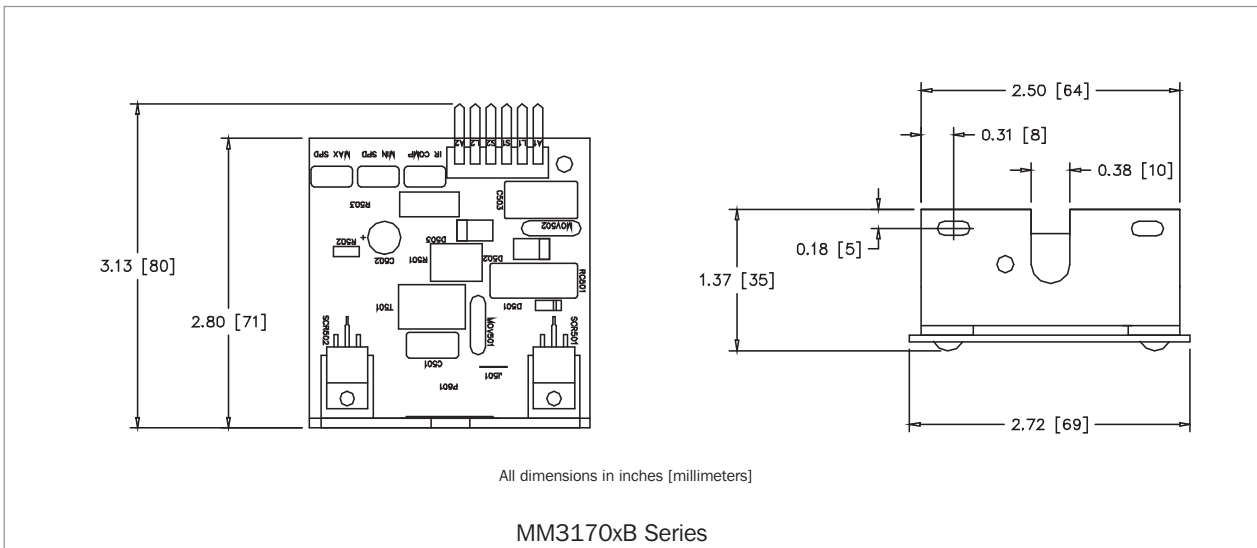
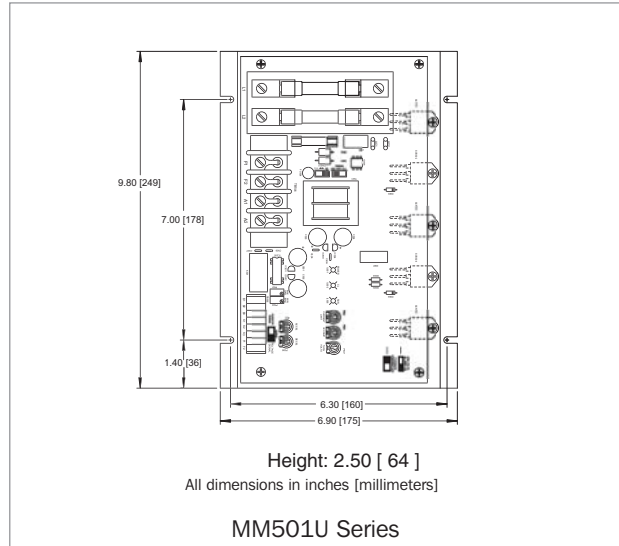
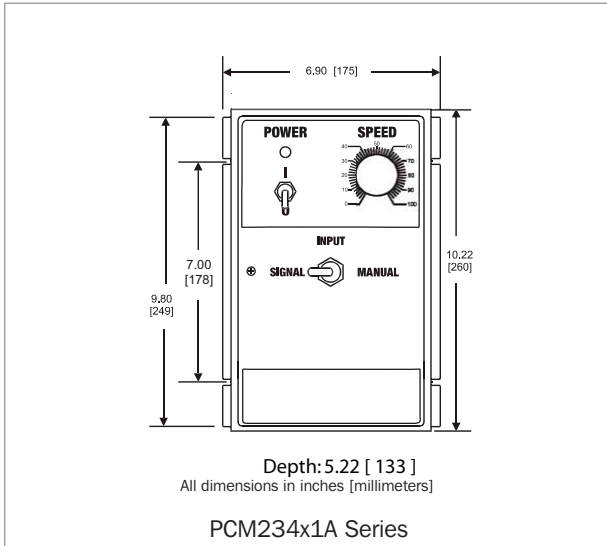

**G**

## Dimensional Drawings

G

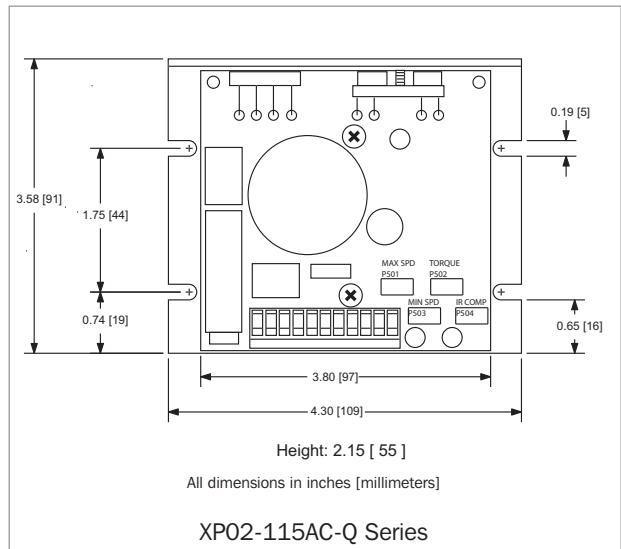
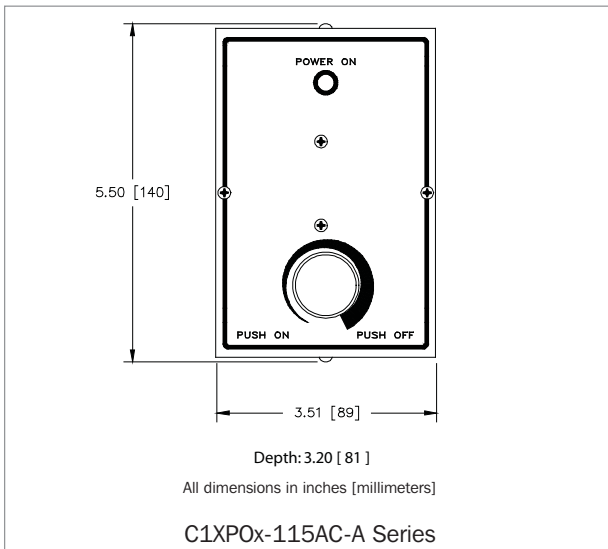
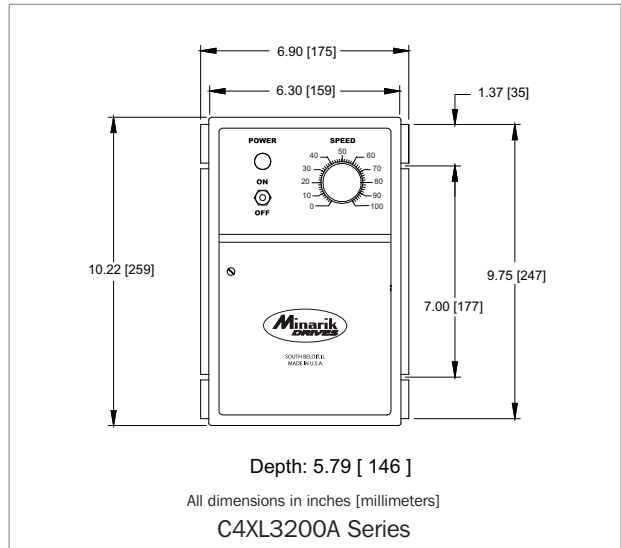
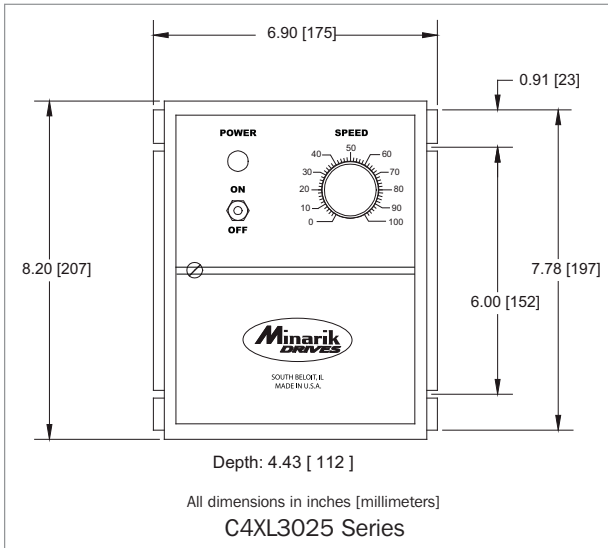
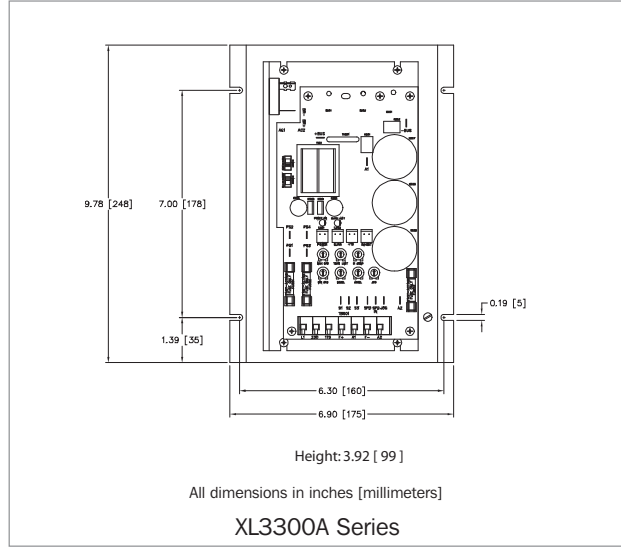
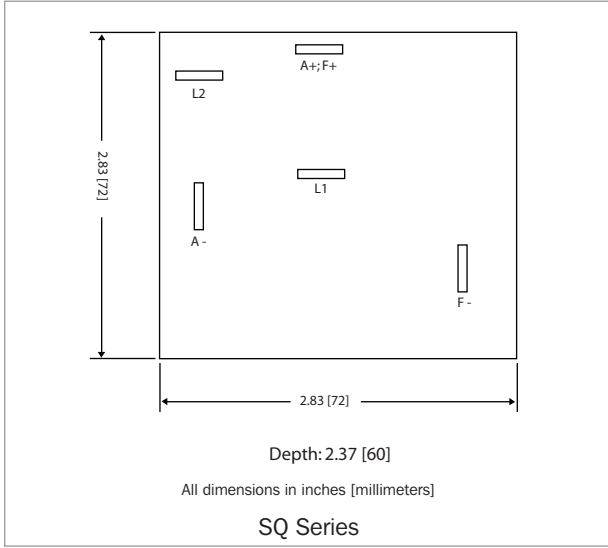

## Dimensional Drawings

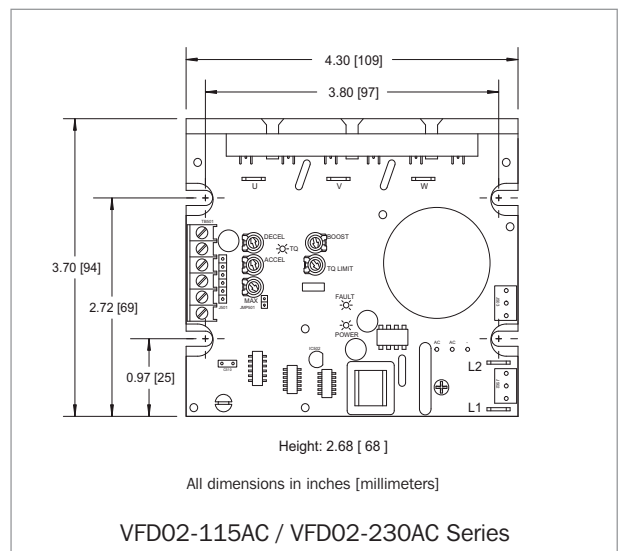
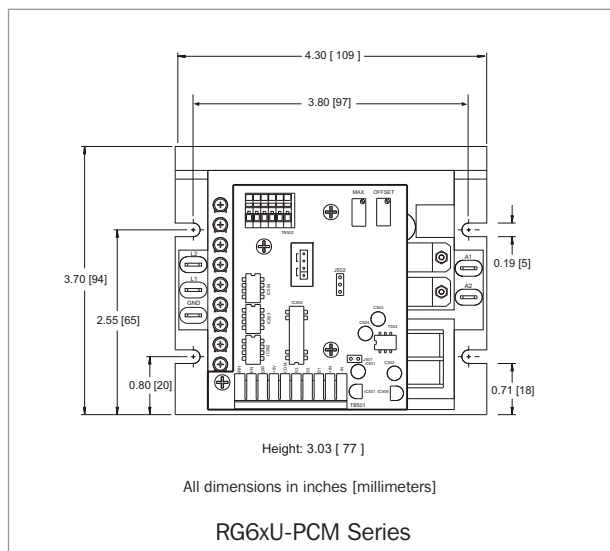
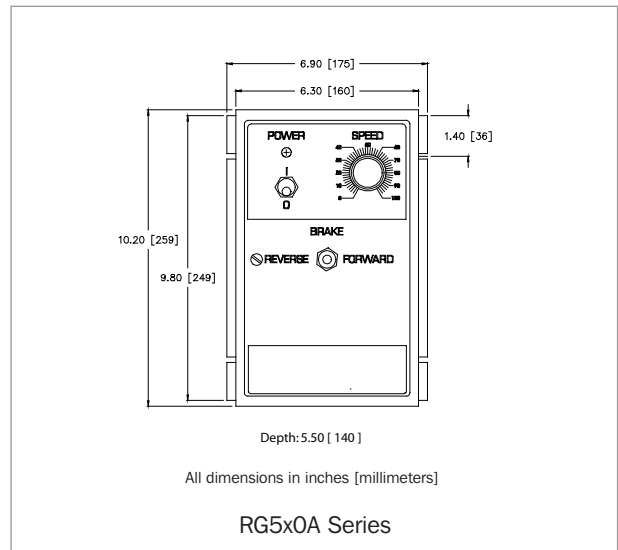
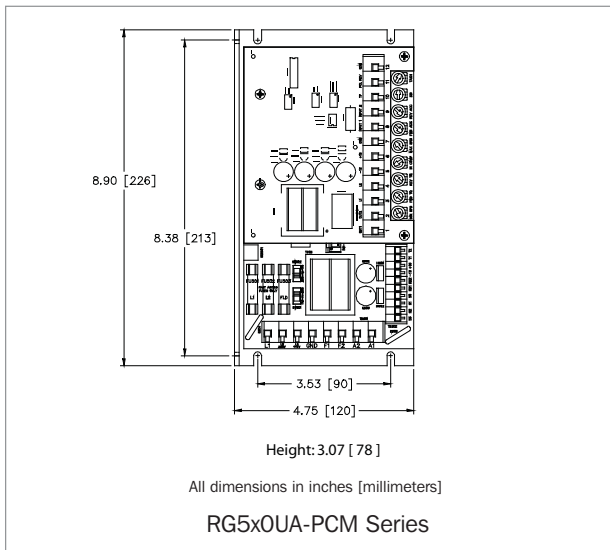
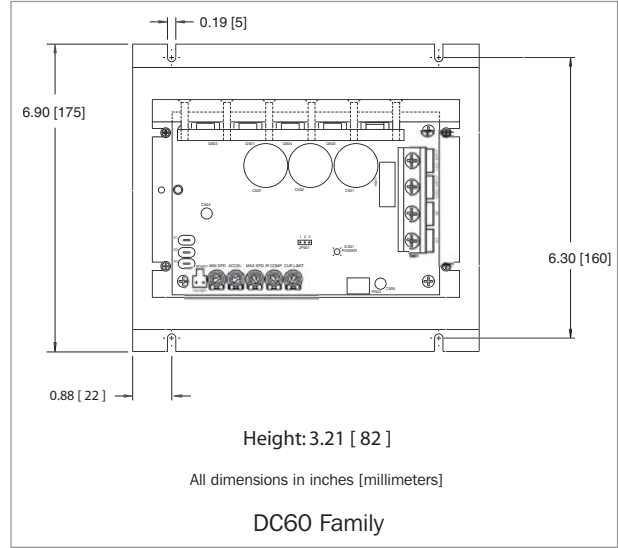
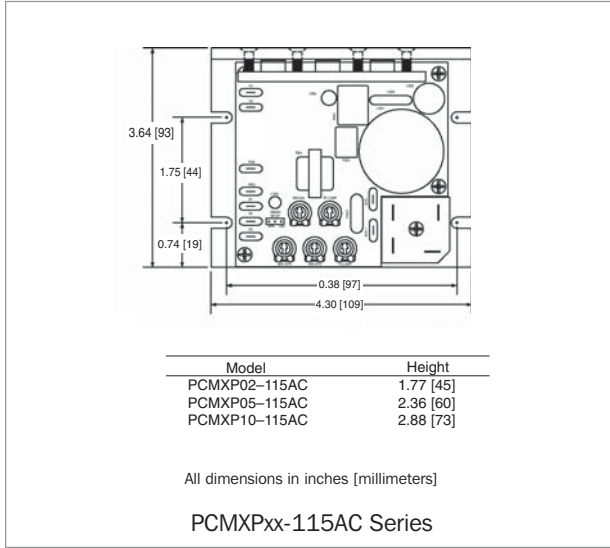

G

## Dimensional Drawings

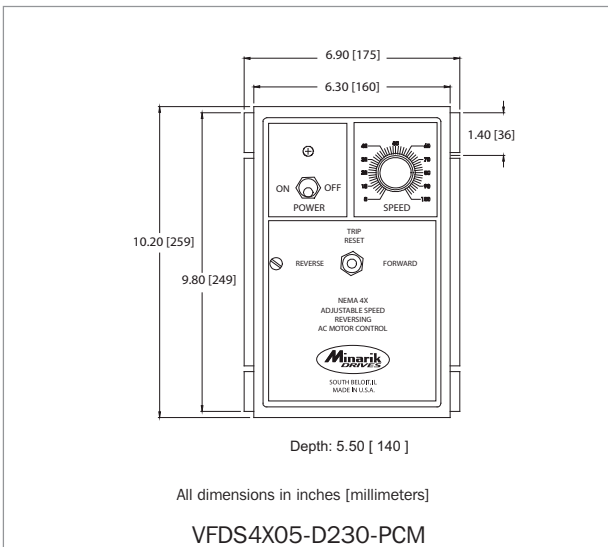
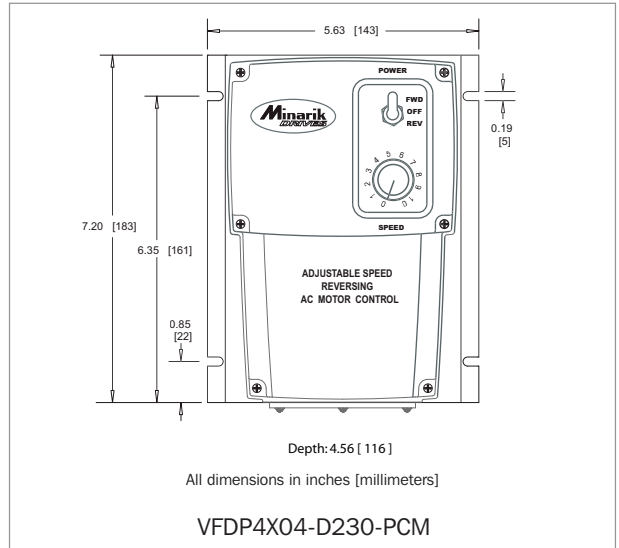
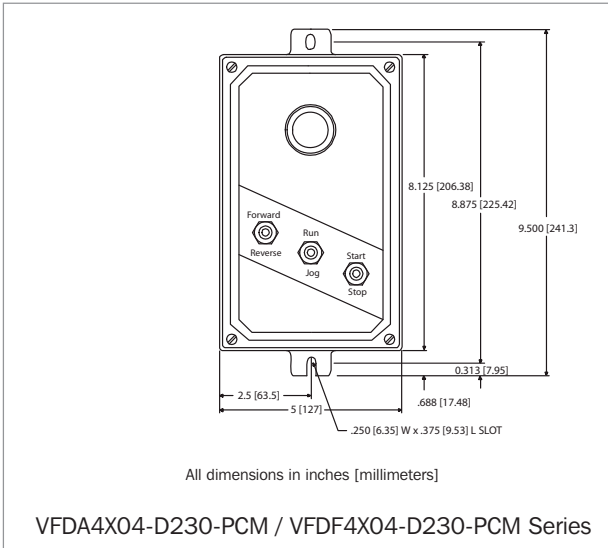
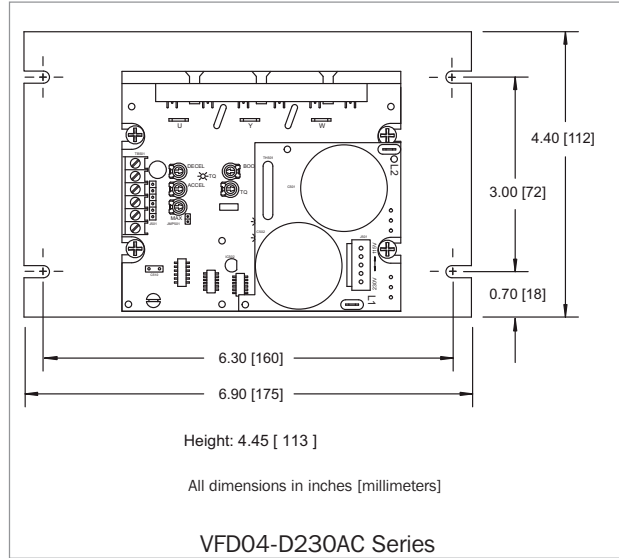
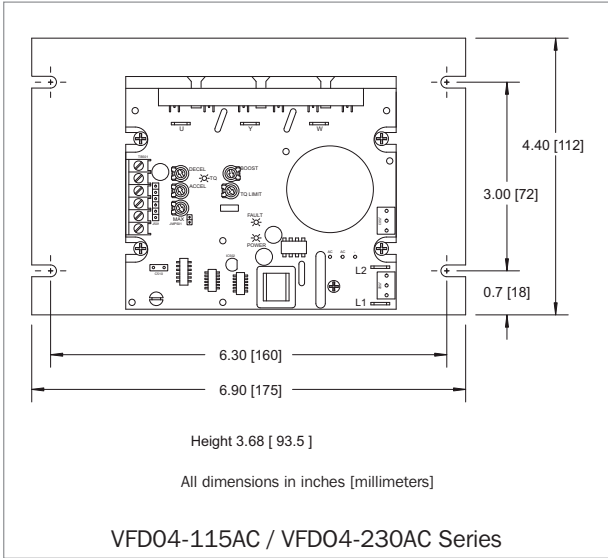

G

# Wiring Diagrams

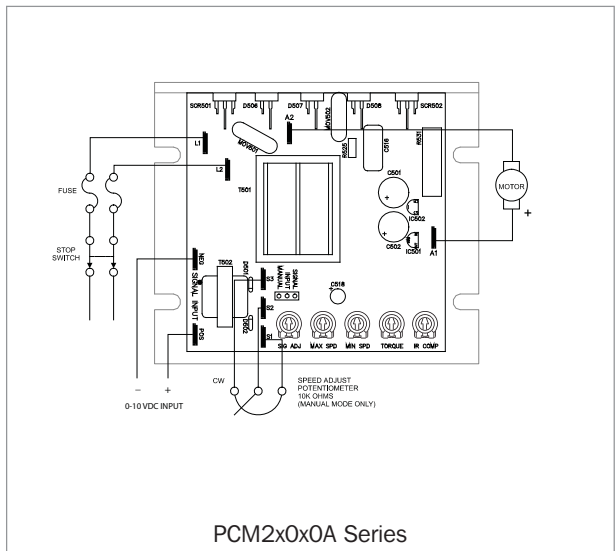
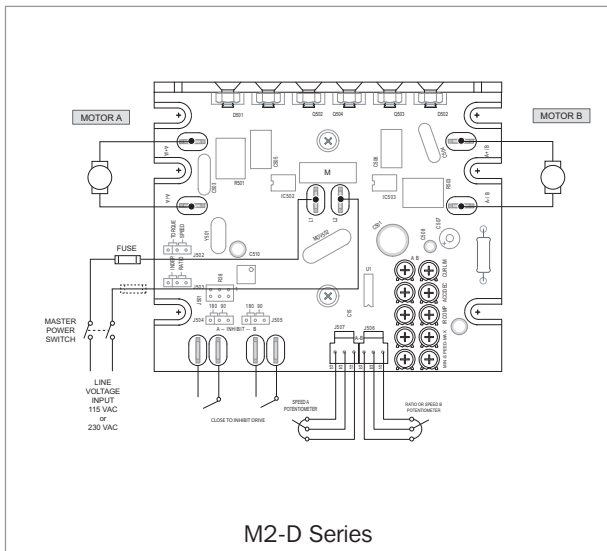
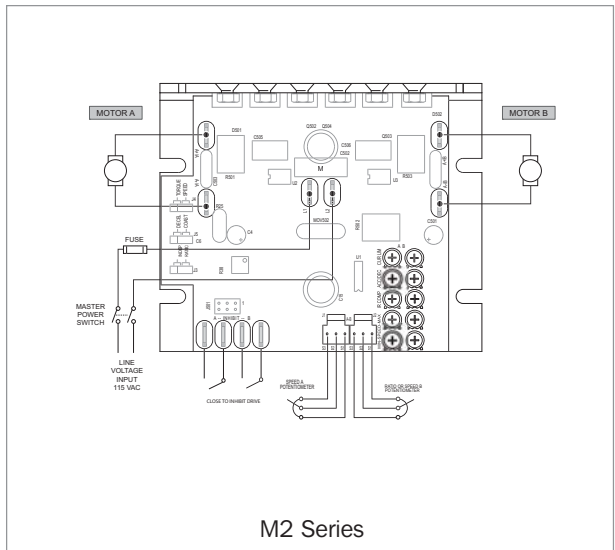
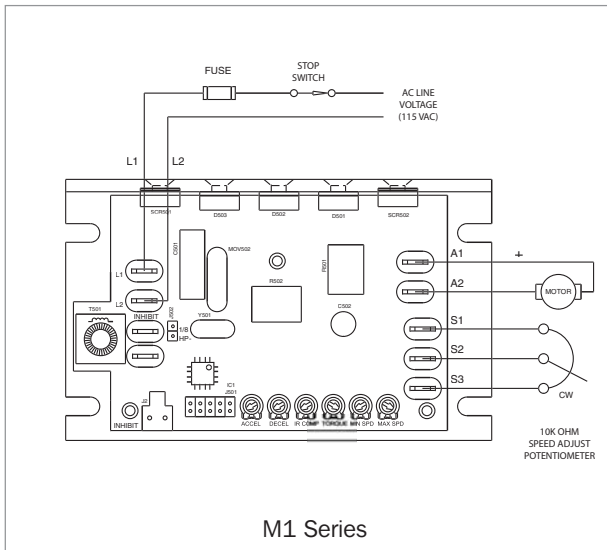
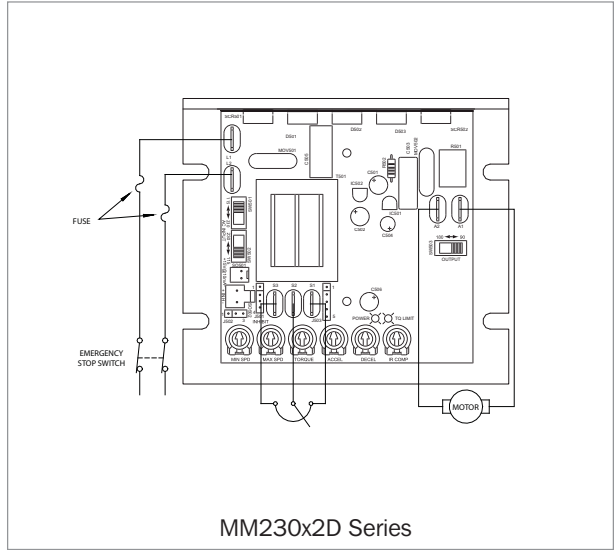
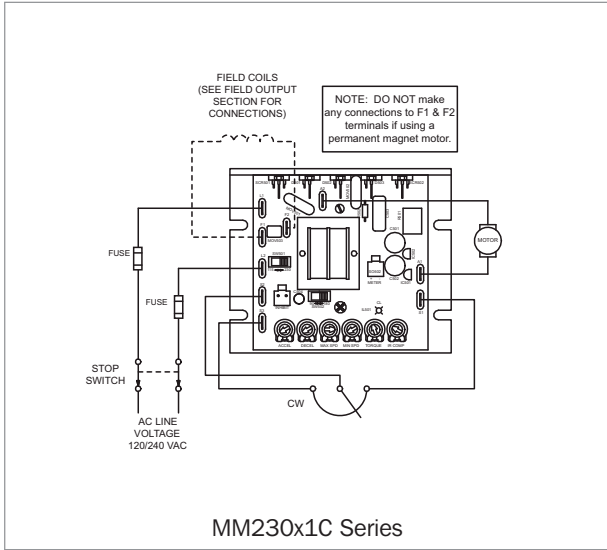

**G**

# Wiring Diagrams

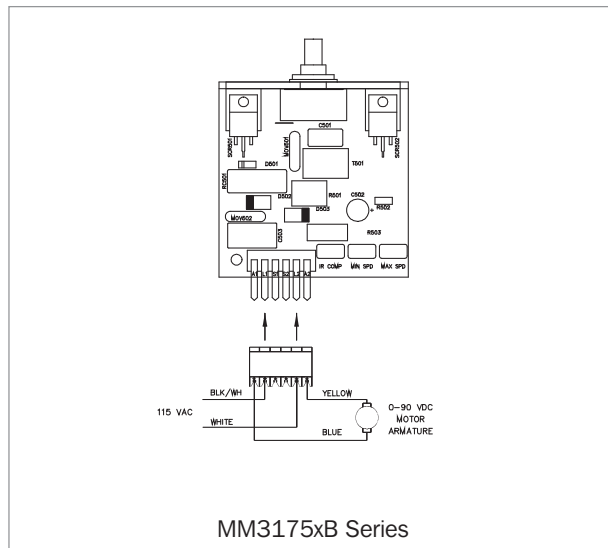
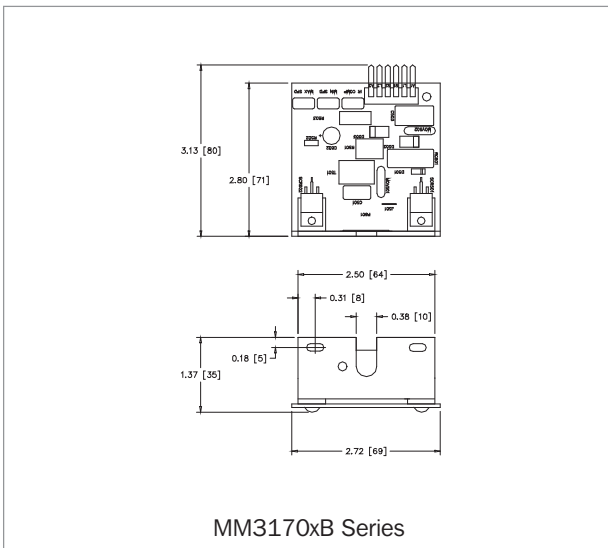
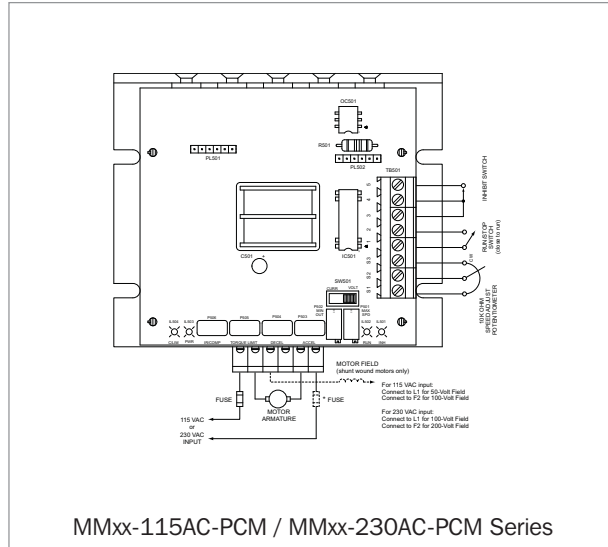
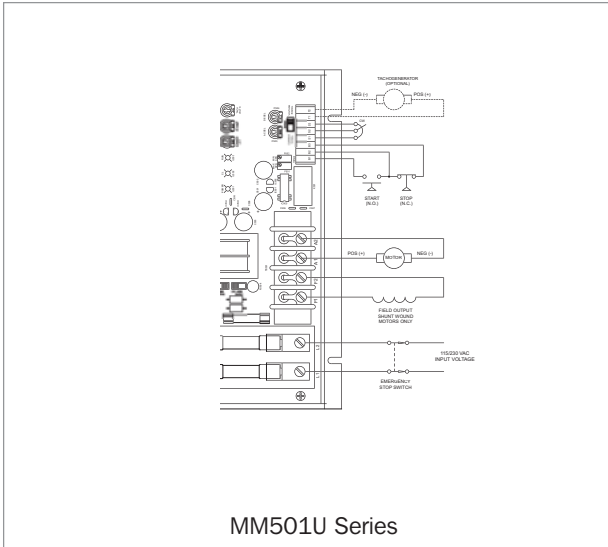
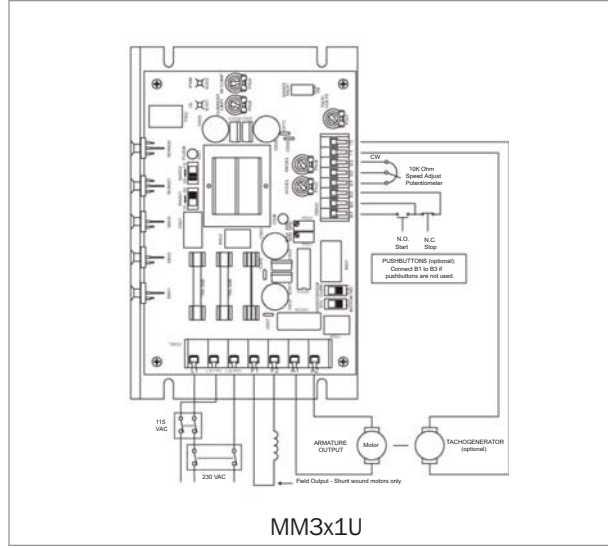
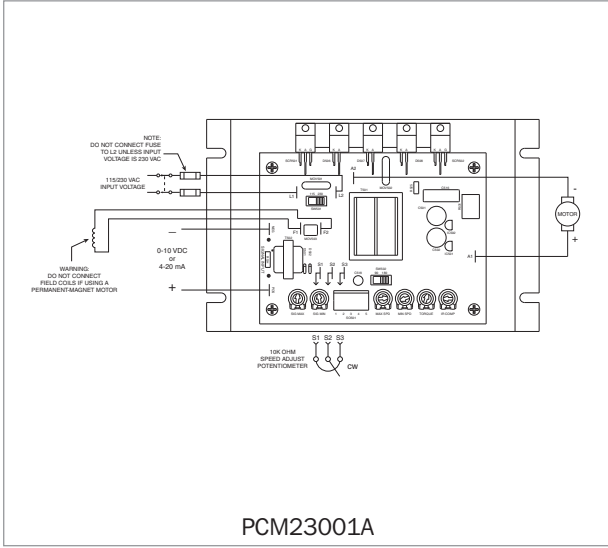

G

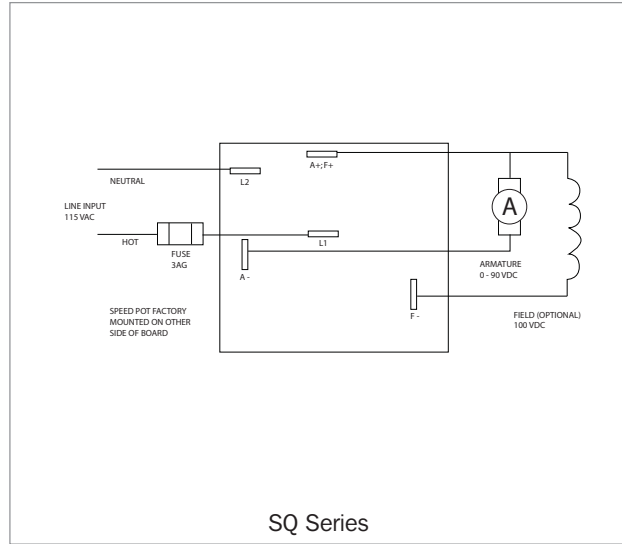
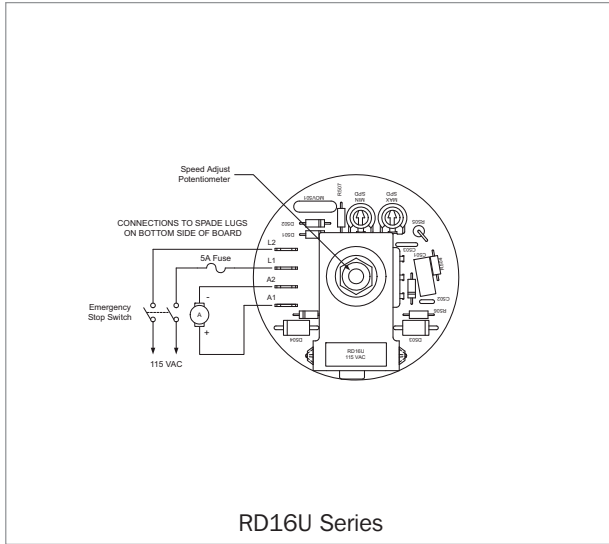

G

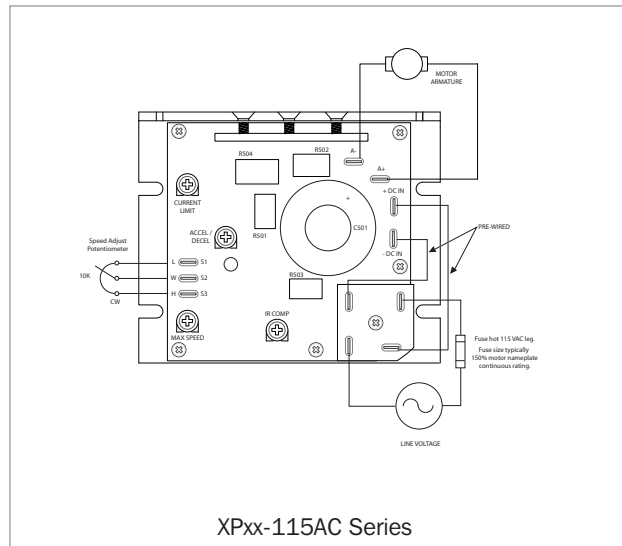
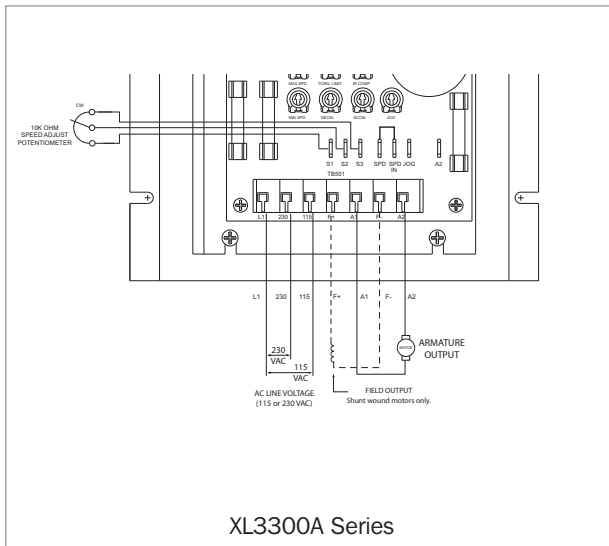
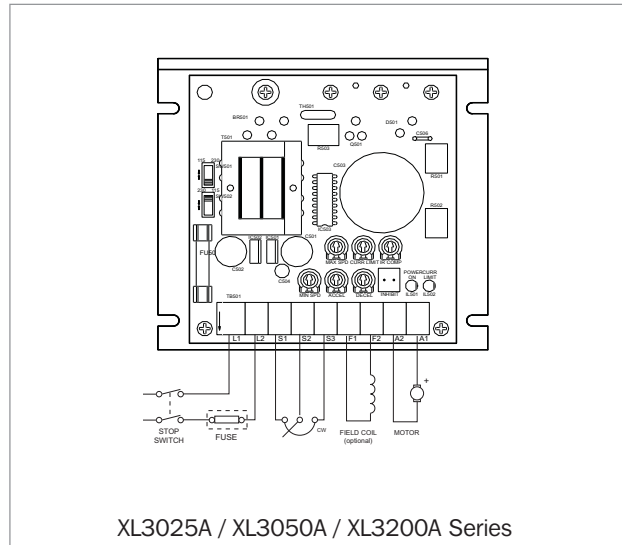
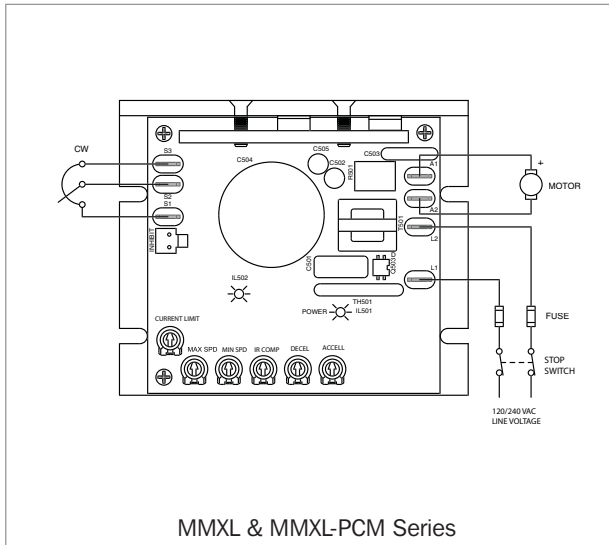

G

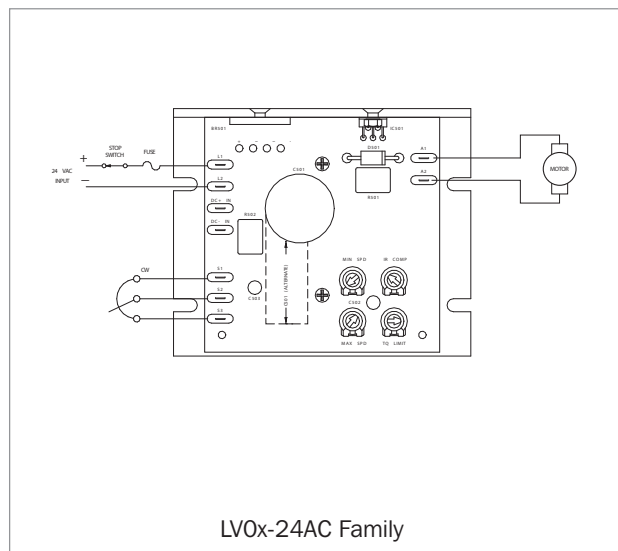
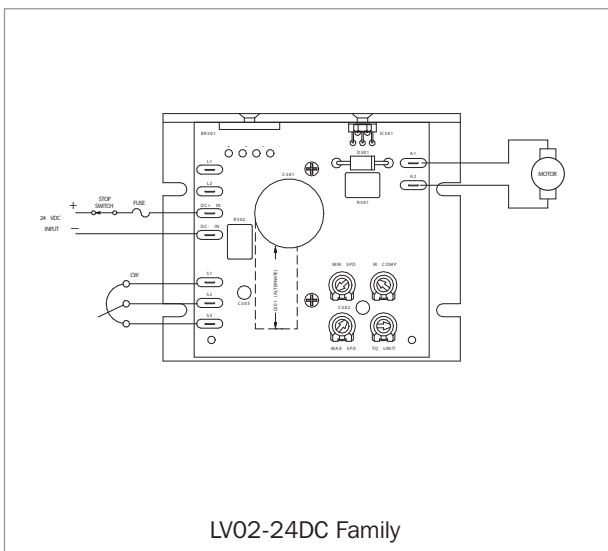
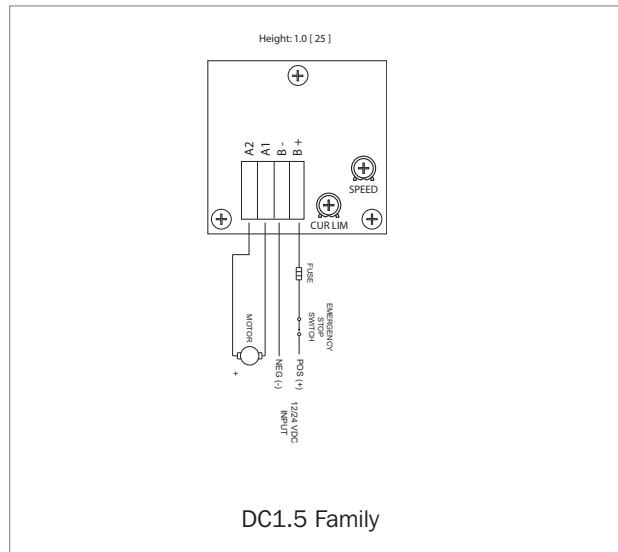
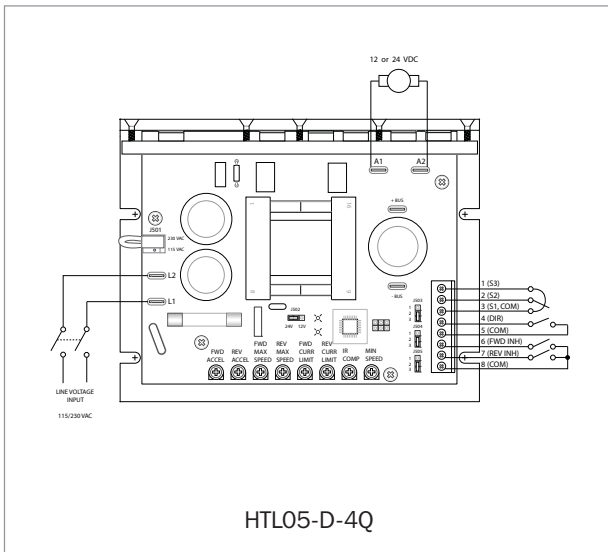
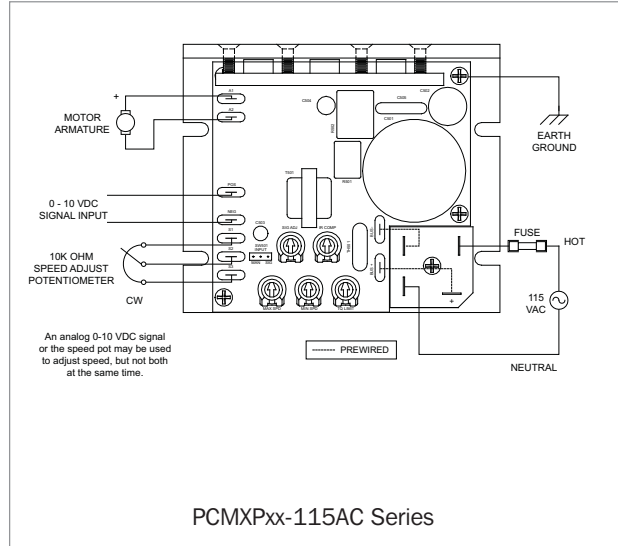
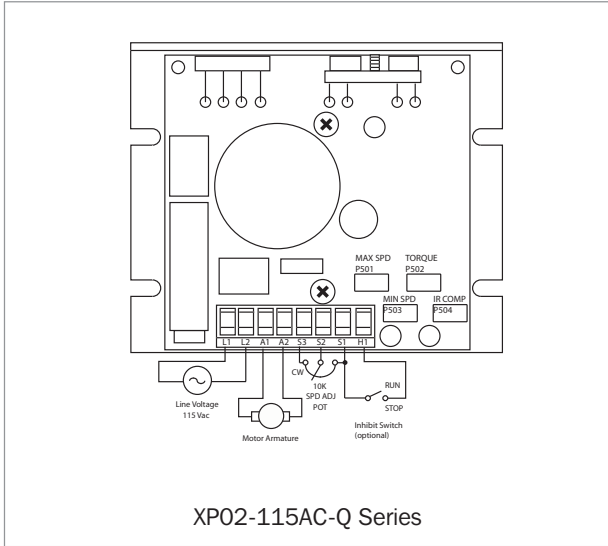



# Wiring Diagrams

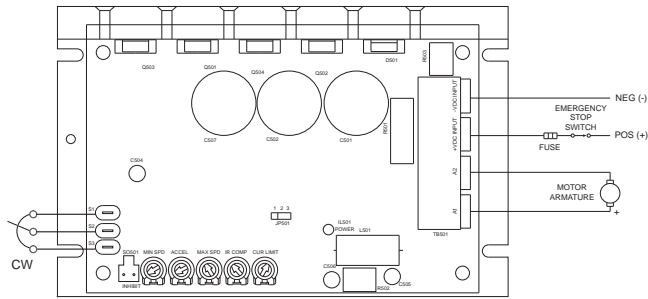

DC16 / DC60 Family

G

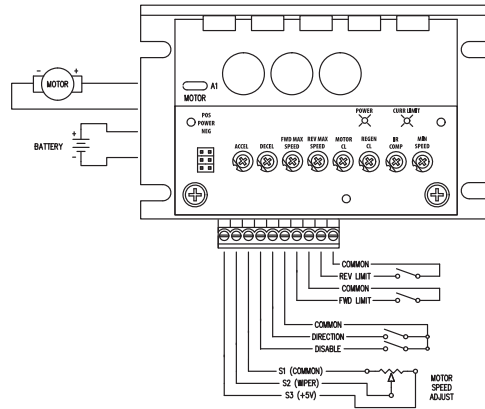

DC30-12/24-4Q Family

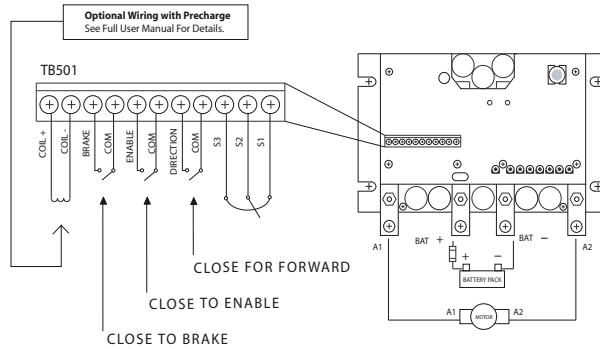

DC250 / DC240 Family

G

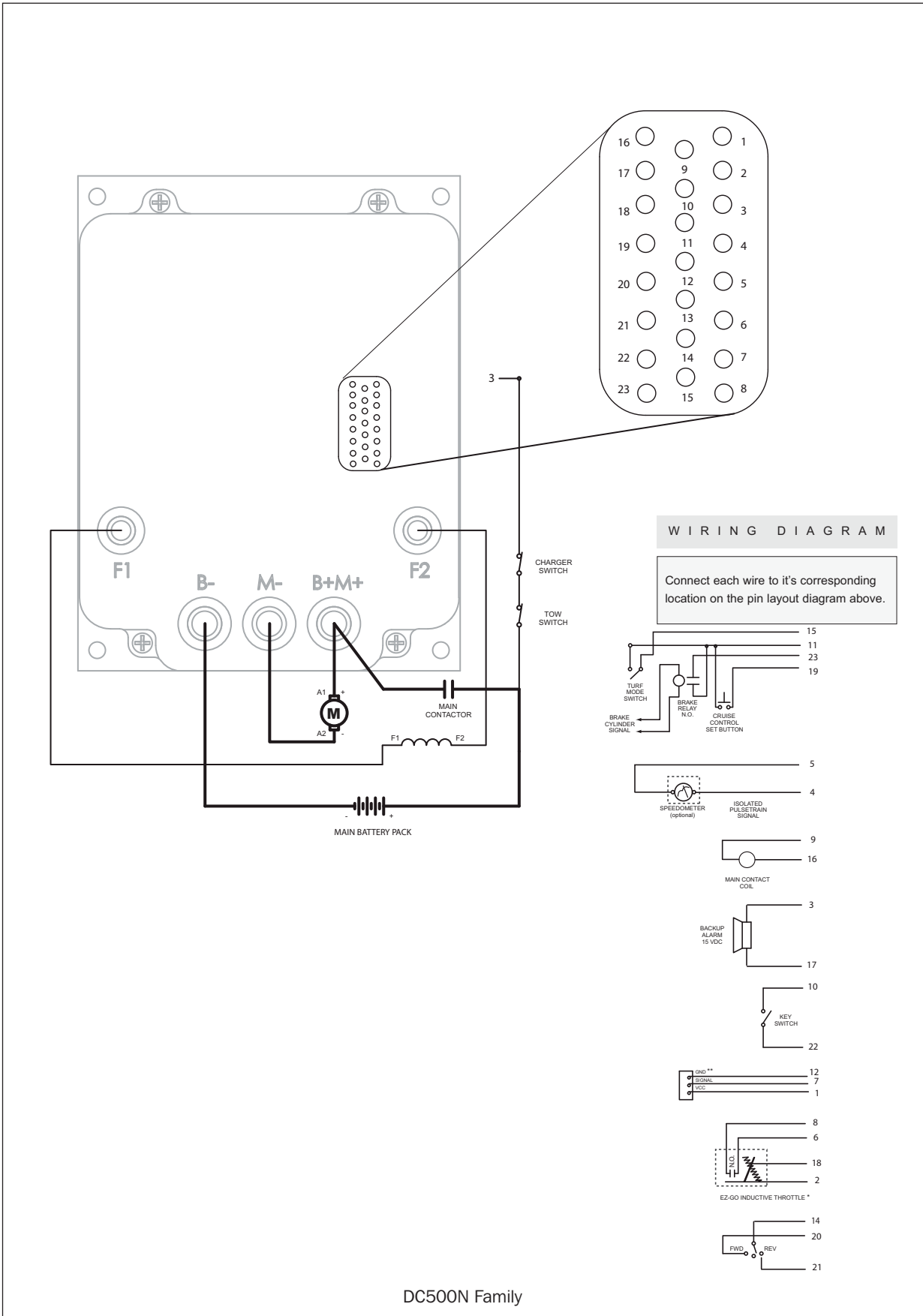

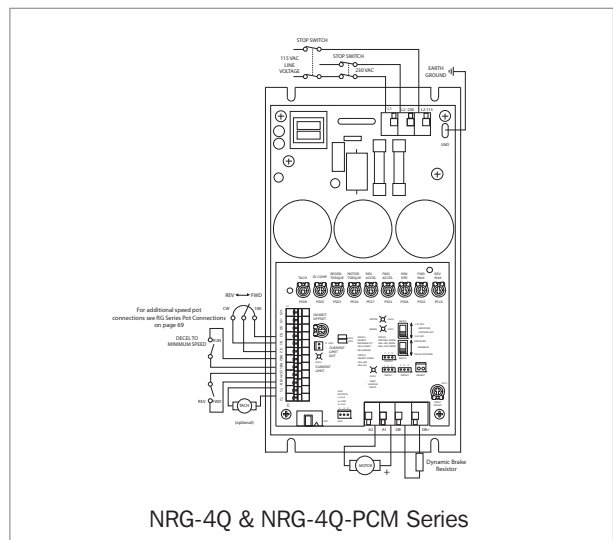
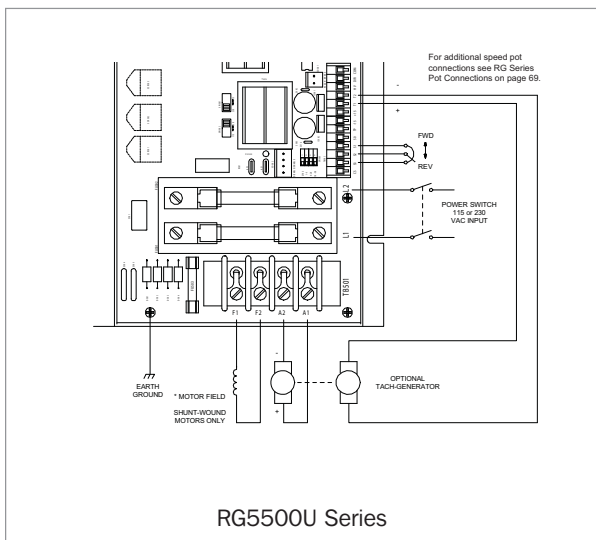
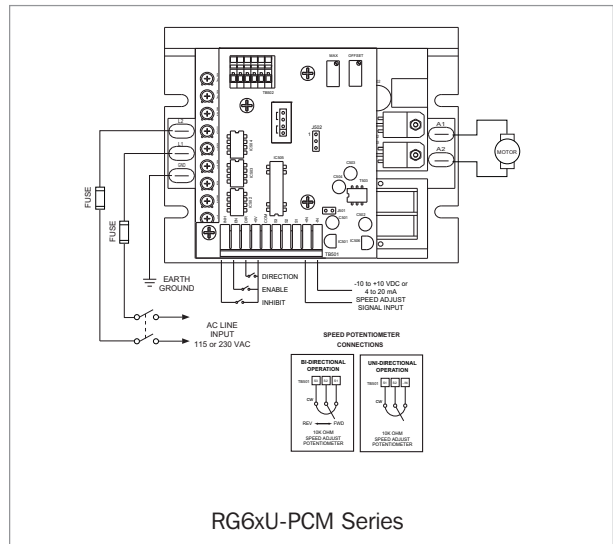
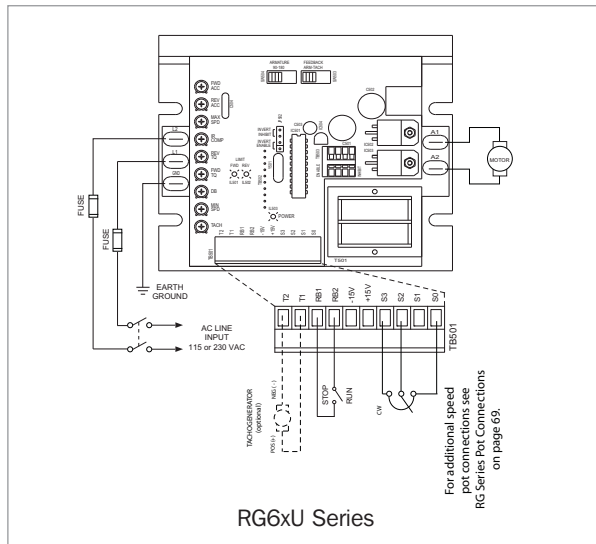
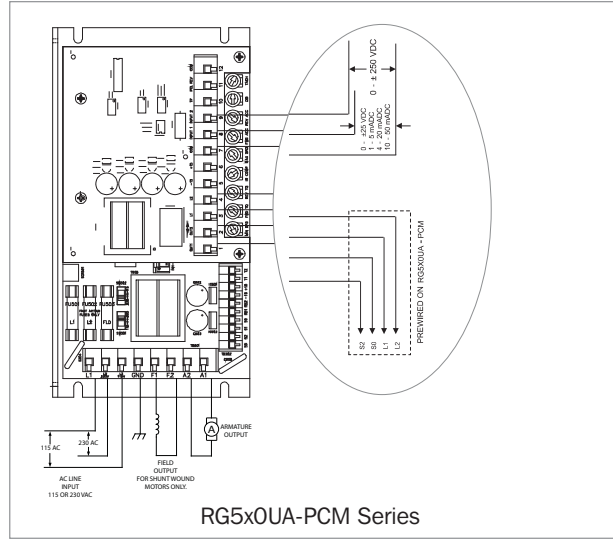
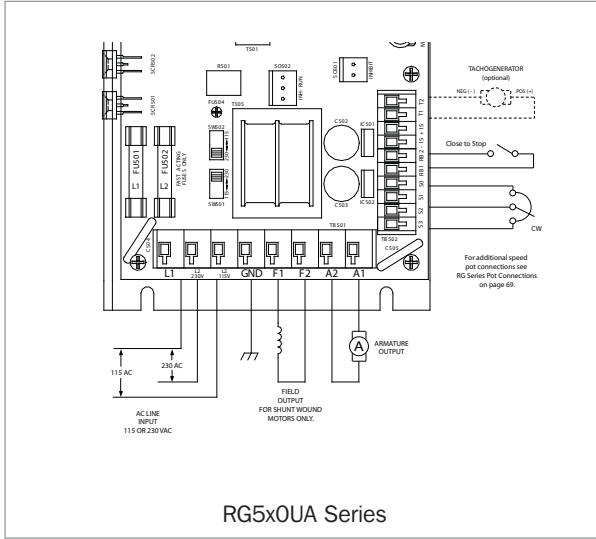

G

## Wiring Diagrams

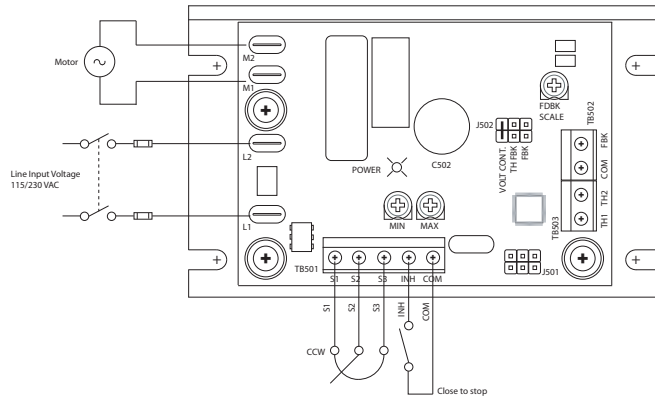

TA10-D Series

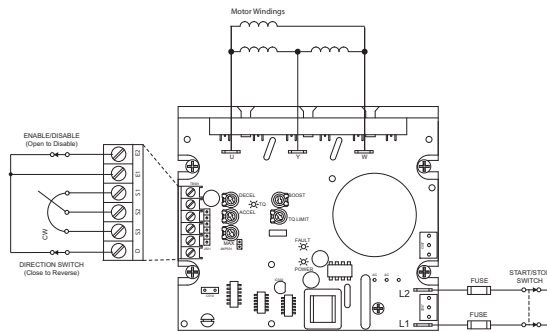

VFD0x-115AC / VFD0x-230AC Series

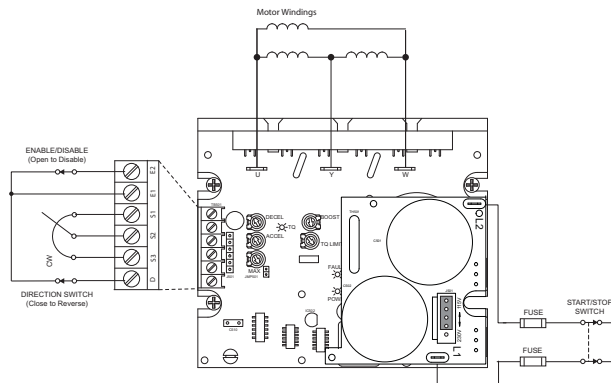

VFD0x-D230AC Series

# Wiring Diagrams

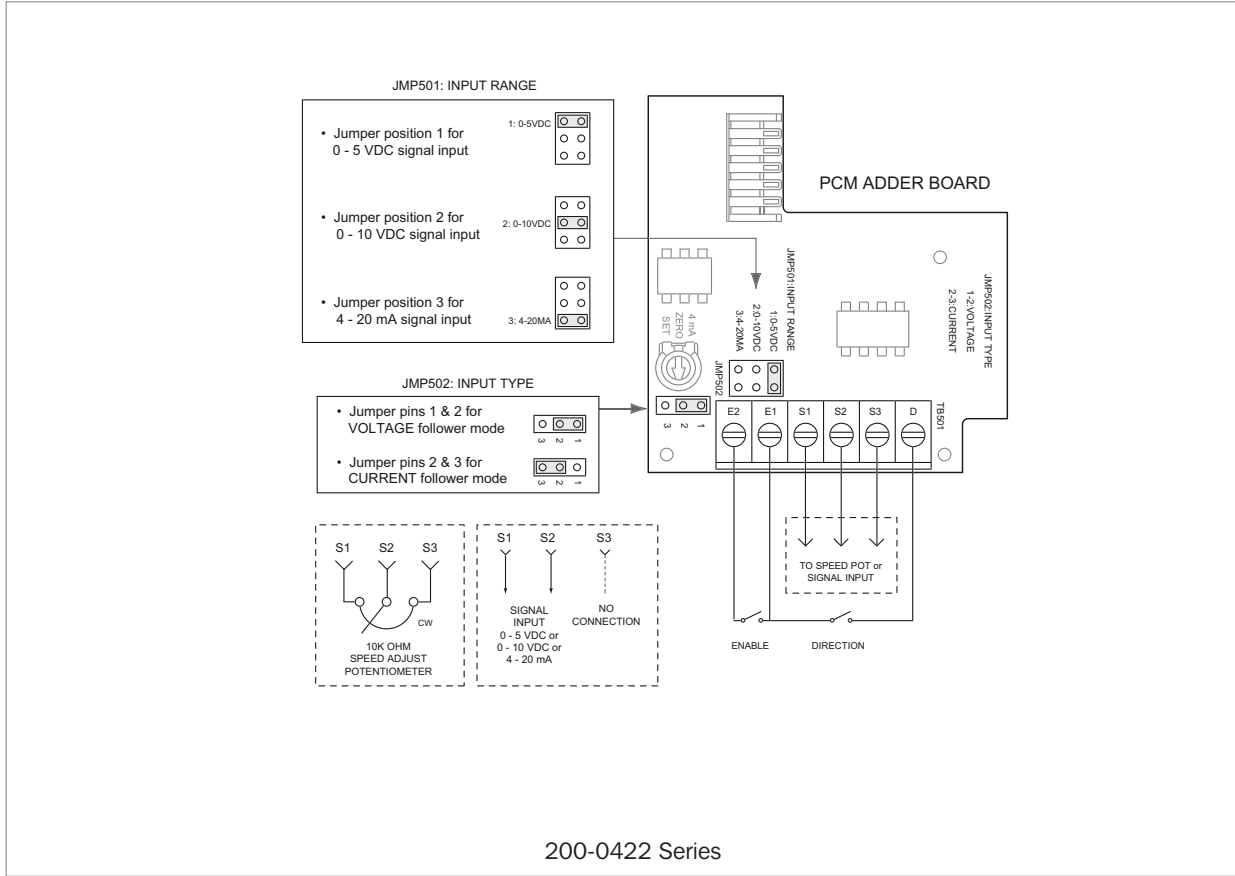

G

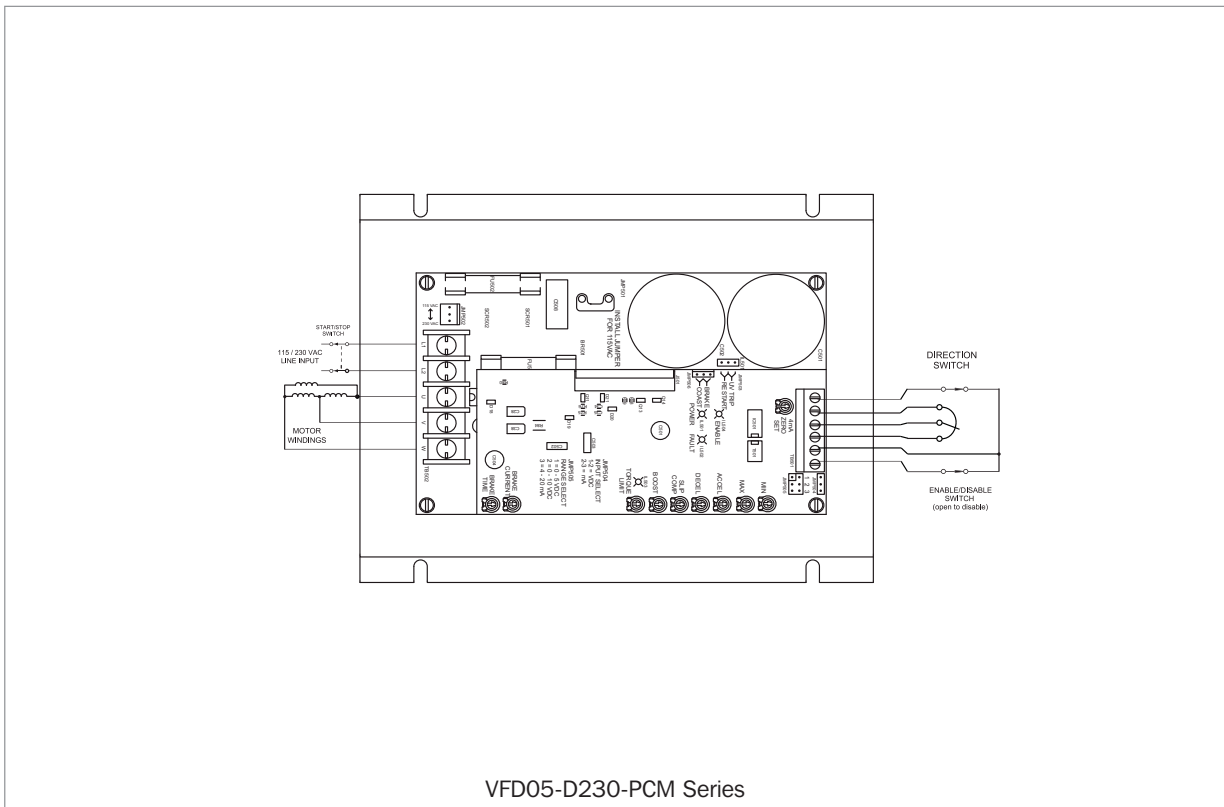

# SINGLE QUADRANT WIRING OPTIONS

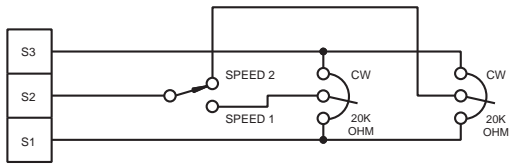

Independent Adjustable Speeds

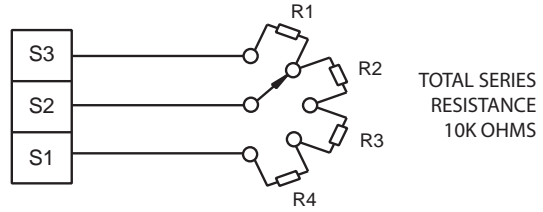

Multiple Fixed Speeds

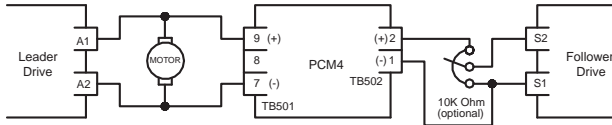

Leader-Follower Application

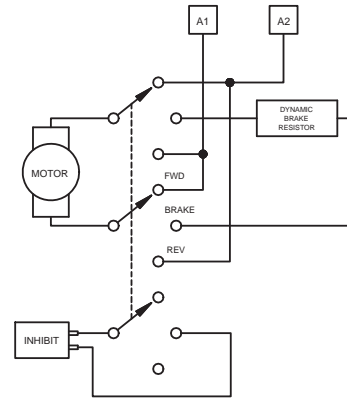

Reversing Circuit Connection

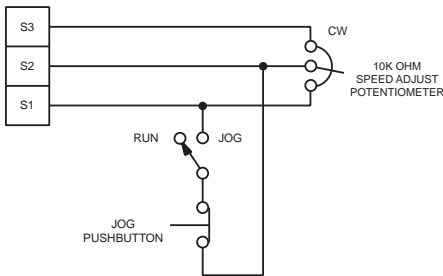

RUN/JOG Option #1

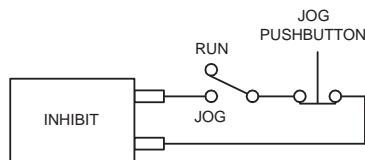

RUN/JOG Option #2

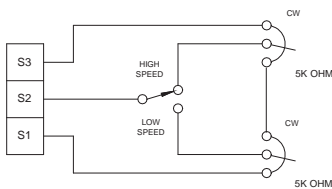

Adjustable Fixed Speeds Using Potentiometers in Series

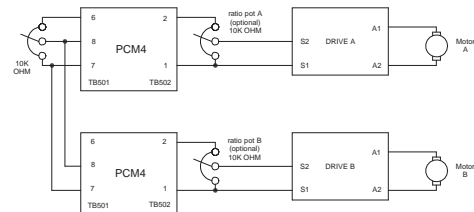

Single Speed Potentiometer Control of Multiple Drives

## SINGLE QUADRANT WIRING OPTIONS

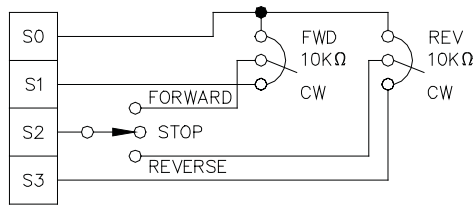

Independent Forward and Reverse Speeds with a Forward-Stop-Reverse Switch

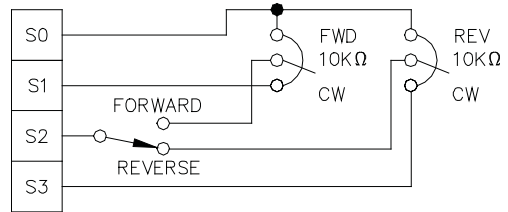

Independent Forward and Reverse Speeds

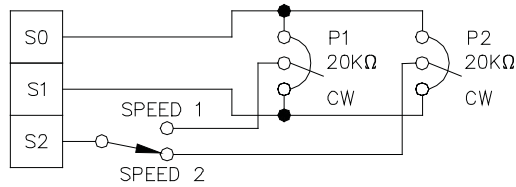

Independent Adjustable Speeds (Forward Direction)

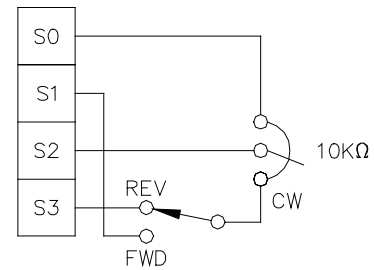

Forward-Reverse Switch

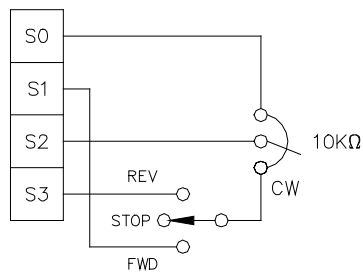

Forward-Stop-Reverse Switch

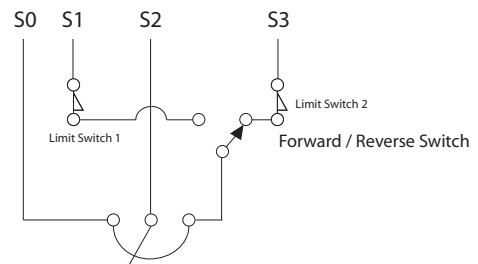

Forward / Reverse Switch with end of travel limit switches

The motors use three phases of alternating current supplied to the stator to provide the speed and torque necessary for your motion control needs. These currents rise and fall in polarity much like an ocean wave. The waves circulate around the stator core at a frequency determined by the user and a drive such as our variable frequency AC Induction VFD-PCM Series. The rotor of the AC motor consists of multiple current paths (coils) integrated throughout an iron core. This rotor construction is typically known as a squirrel cage design. Reaction between stator and rotor coils result by transformer action across the stator/rotor air gap. The induction motor is essentially a transformer with a rotating secondary. The force that exists between primary and secondary coils in a transformer appears as useful torque in an induction motor. The rotor is pushed into rotation by the ensuing stator wave. The frequency of the waves establishes the maximum speed but it does not provide the torque necessary to run at that speed. The voltage and resulting current provide the actual power to do the work.

G

$$\text{RPM} = (120 \times \text{Hz}) / \text{Poles}$$

The stator field rotates at a speed determined by the frequency and number of poles. The rotor always turns at a lower speed than the stator fields; if the rotor turned at a synchronous speed, there would be no change in flux linkage, no induced current, and no torque. The small difference in speed that produces flux cutting and motor action is called the slip.

Our VFD-PCM Series accepts either 115 VAC or 230 VAC input and provides respective 3 phase output for these motors. The PWM output gives us a high dynamic response for high performance use, a very wide speed range and smooth motor control through zero speed. The frequency range can be varied from 0 to 120 Hz with constant torque available up to 60 Hz, and constant horsepower available above 60 Hz. The drive features solid-state reversing with adjustable acceleration and deceleration. They also feature adjustable current limit, line starting and stopping,

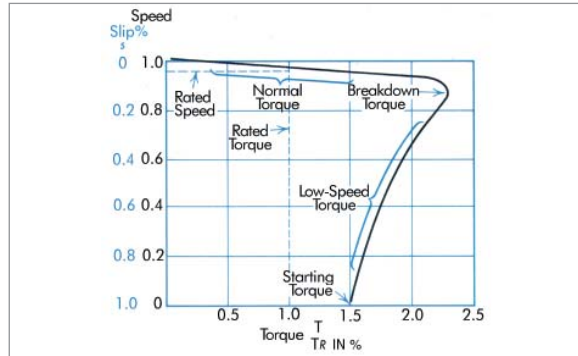
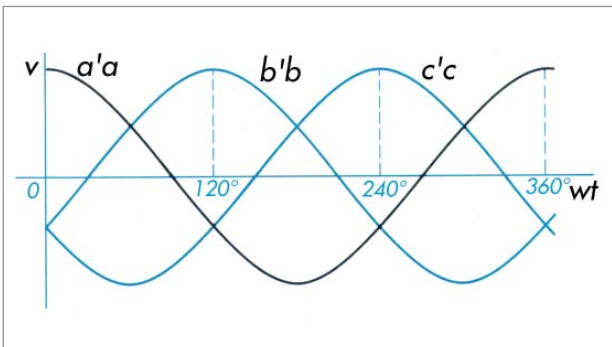

min. and max. speed control, slip compensation, acceleration, torque boosting control, and many more features. Standard models are available to power induction motors up to 1.5 HP.

The key advantages of this motor design vs. the permanent magnet brush or permanent magnet BLDC motor line is simplicity, reliability, and durability. Positional feedback and high energy rare earth magnets are not necessary with this type of machine. Users may take advantage of standard power lines and wall outlets offering 115 VAC or 230 VAC. The complexity of these past machines did not come from the motor, but the control of that motor. Minarik has developed the ideal economical drive solution to this dilemma with the aforementioned VFD-PCM drive. This drive gives you complete control of three phase induction motors.

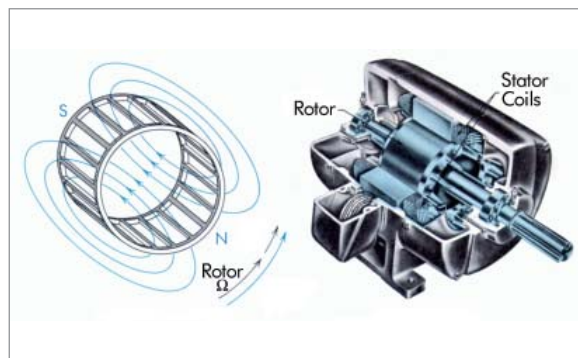



Regenerative drives have the ability to turn the mechanical energy required to brake a DC brushed motor back into electrical energy. They do this by electrically reversing or braking DC brushed motors at a user-defined rate. Therefore, there are no mechanical relays or resistors to wire or wear out. By being able to control torque in the opposite direction of speed, Regenerative drives can control overhauling loads caused by gravity or inertia. Minarik Regenerative drives run on either SCR or PWM technology, giving you more options to choose from. Any application that requires reversing, braking, or the control of overhauling loads should use a Regenerative drive.

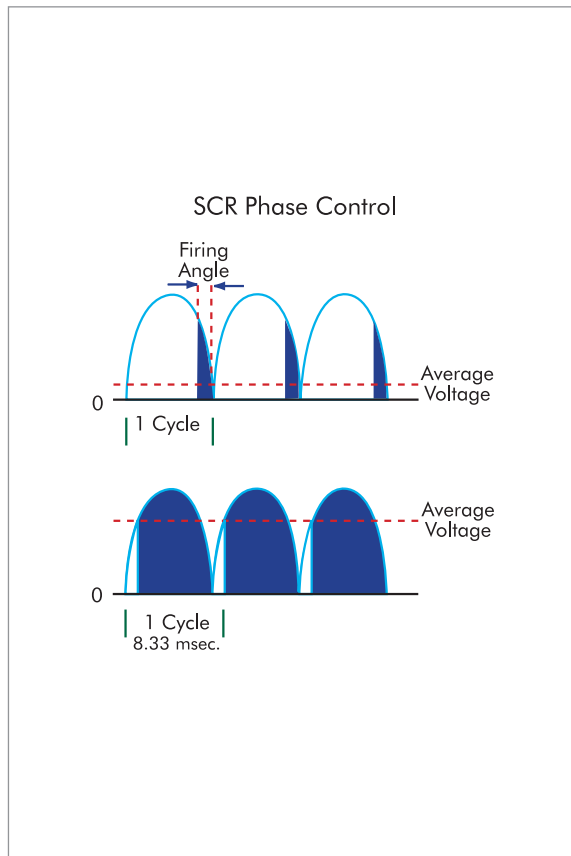

Silicon Controlled Rectified (SCR) drives are excellent for your everyday DC brushed applications. They have been very popular and are low cost. Typically, SCR drives have 60:1 speed ranges and form factors of 1.37 at base.

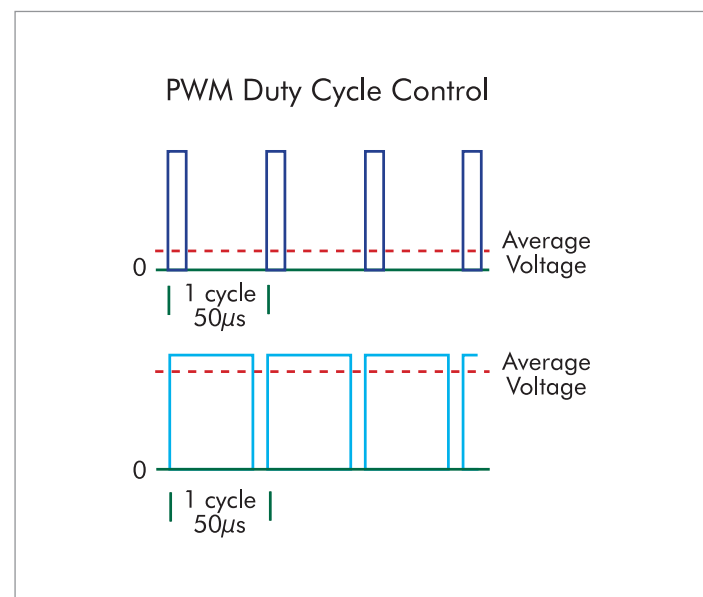
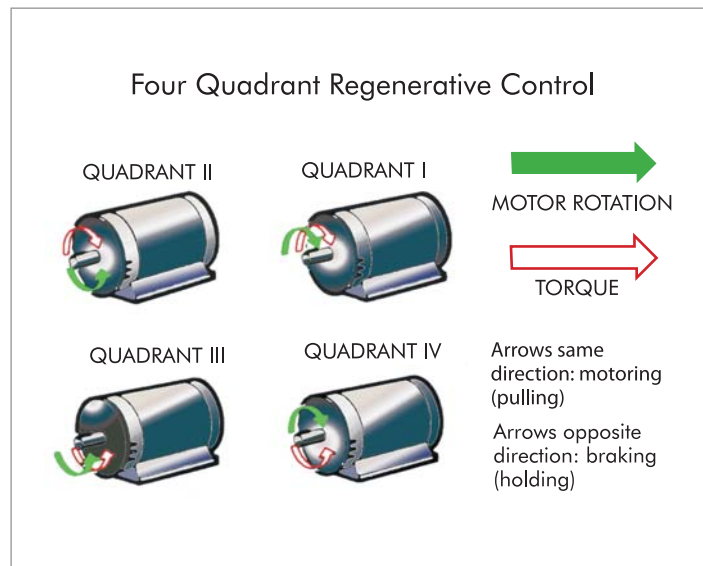

Pulse Width Modulated (PWM) drives perform well in similar applications as SCR drives with several more advantages. PWM drives add more flexibility to applications by being able to run on either AC or DC voltage. Their power devices switch at a rate over 120 times faster than SCR power devices thus producing "cleaner" DC voltages. A "clean" voltage means your motor will run cooler and quieter over a wider speed range (100:1 compared to 60:1 of SCR drives). A cooler brushed DC motor will require longer maintenance periods between replacing the brushes. The higher switching frequency is above the audible range, so there is no hum from the motor. The wider speed range allows you to run the motor slower while maintaining control. Applications requiring cool, quiet, lower maintenance operation are perfect for PWM drives.

Speed range is usually defined as the ratio of maximum system speed to the minimum system speed. For example, if the maximum speed is 1,750 RPM, and the speed range is 100:1, the minimum speed will be 17.5 RPM. Using DC motors and drives as an example, let's analyze the three speed ranges listed below.

- 1) Motor speed range
- 2) Drive speed range
- 3) System speed range

### G

## 1. Motor Speed Range

This is generally published as the fastest a motor can run trouble-free divided by the slowest it will run before it begins to "cog" (or "step"). Cogging occurs due to static friction in the motor, inefficiencies in a pre-mounted gearbox and/or spacing between the commutator slots of a DC brush motor. The fewer the number of slots, the sooner (or higher speed) the motor will "step".

Fan-cooled motors rely on the fan to stay below the maximum temperature of the motors. Often, a minimum fan speed is necessary, thus narrowing the motor speed range. Many motors can run at 1 1/2 to 2 times their rated speed. Their potential speed range may be artificially high.

## 2. Drive Speed Range

This is generally published as the maximum output voltage of the drive divided by the minimum output voltage of the drive. However, it should be published as the maximum output from the drive (where it can properly regulate motor speed), divided by the minimum output (when it can properly regulate motor speed).

The drive regulates motor speed by changing its output voltage in response to the motor load. More voltage will be applied when a motor begins to slow due to increased loading. Once the drive exceeds the maximum output voltage limit, it cannot output any additional voltage. At this point, the drive surpasses the speed range and fails to regulate properly.

The same concept holds true at minimum speed. The drive may be capable of running a motor, with "cogging," at 1 RPM. However, if the motor stalls when loaded, the drive speed range cannot be used at the lower end since the drive allowed the motor to stall.

## 3. System Speed Range

Those who specify a system, or end-users, are usually only concerned with the most important specification, the system speed range. However, the system speed range is a difficult specification to obtain from a catalog. Normal listings show motor speed range and drive speed range only; rarely will you find system speed range listed. We determine the system speed range by dividing the motor's speed at the maximum drive output voltage (with proper regulations) by the motor's minimum speed (before "cogging"). We combine only the motor and drive parameters that limit the system speed range. The maximum drive output is used because it is well below the maximum speed of the motor. The minimum speed of the motor is used because it is well above the minimum output of the drive (usually 2 to 3 volts are required to overcome the "dead zone" point of a motor).

Many things may affect the actual system speed range. Difficulties can arise when defining the minimum and maximum system speeds. For example, perhaps the bench tests and burn in were unidirectional. The way the brushes seat on the commutator could affect speed range in one direction. Ambient moisture might affect air gap fluxes of the commutator. Temperature changes in ambient air and/or the motor will affect magnetic field strength, thus affecting system speed range as well.

The most often overlooked culprit in narrowing the system speed range is the form factor of the drive output. The form factor from a drive worsens as motor speed reduces (lower output voltage) unless Minarik PWM drives are used. This is a major concern when specifying motors, and deserves its own explanation (see form factor discussion on pg. 78).

Consult Minarik's factory engineers for assistance in selecting a motor and drive that will meet your system's speed range requirements. Typically, Minarik specifies SCR drives for a 60 to 1 speed range and DC brush PWM drives are either 80 or 100 to 1 speed range.

## REGULATION

We define the speed regulation of a DC brush-type motor as the drive's ability to hold a desired set speed as the load seen by the motor changes. Speed Regulation is measured as a percentage of base speed, not set speed. For example, a 1% regulation on a 1750 RPM motor means the speed may fluctuate  $\pm 17.5$  RPM from no load to full load.

Once the motor sees a load in excess of its rating, the drive may go into "current limit" to protect the motor. Until then, we want the drive to regulate speed. The amount of regulation required depends on the application; users set its value by calibrating the IR COMP trimpot on the drive.

Applications requiring tight regulation might be:

- Cut-to-length
- Leader-follower (involving multiple axes)
- Winding applications
- Printing, marking, labeling, and gluing (requires a high level of accuracy)

Applications where precise speed regulation may not be as critical:

- High-speed braking and reversing applications (like index tables, palletizers, strapping, cranes, hoists, lifts)
- Applications where simply moving from point A to point B is sufficient
- Applications where an operator uses visual feedback (eyesight) to make speed adjustments

## CURRENT LIMIT

Motors can handle currents in excess of their rated values for short periods of time. However, if operation outside of rated values occurs for an excessive duration of time, armature and brush life reduce, and eventually permanent motor damage will occur. Minarik drives generally possess a current limit (or torque limit) trimpot adjustment that allows users to limit the amount of current drawn by a motor. Consequently, users can limit the torque delivered to the load from a motor.

**Note:** This adjustment is designed to limit steady state overloads and may not limit very fast changing (impulse) type loads.

G

## EFFICIENCY

Efficiency is usually described as  $\eta = (\text{power output} \div \text{power input}) \times 100\%$ .

System efficiency corresponds inversely with power consumption from the power company. Higher system efficiencies consume less electricity than lower system efficiencies. They also correspond, though not linearly, with system life. Primarily, we are concerned with the efficiencies of the motor, drive and system.

When a device cannot convert all of the input power into work, the excess energy is wasted as heat and sometimes, noise. Usually, one must know the efficiency of the motor and drive only for a calculation of heat dissipation; for example, when sizing an enclosure for a drive. Another example might be the sizing of a cooling fan for a non-ventilated motor. The greatest contributing factor to motor and system efficiency is form factor. The graph below describes typical system efficiencies using Minarik drives.

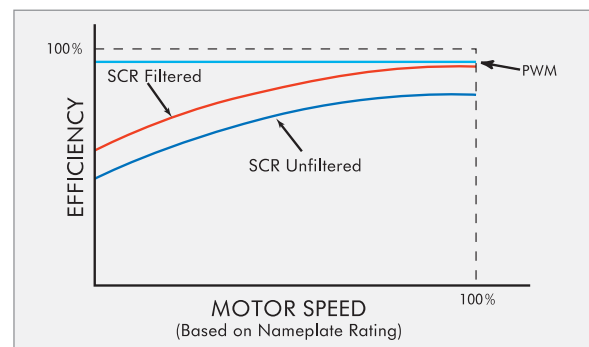

### DEADBAND

Some Minarik regenerative drives contain the deadband feature for applications requiring the ability to adjust the time that elapses between current reversals. Adjustments to the deadband trimpot will alter the degree to which a motor resists changes in shaft position at zero speed. It performs this function by applying a small AC voltage to the motor armature.

G

### MINIMUM (MIN) & MAXIMUM (MAX) SPEED

These application specific settings are present on most drives as a convenience to users. The minimum speed trimpot (MIN Speed) allows one to adjust output voltage to the motor when the reference to the drive is at a minimum. The reference may be 0 volts input with a 0-10 VDC signal, or with the main speed potentiometer turned fully counter clockwise. If the application requires the motor to continue rotating, even with a zero reference input, rotate the MIN speed trimpot clockwise to the desired minimum speed. The minimum speed is important in applications such as conveyor ovens, where stopping the motor could damage the product in the machine.

The maximum speed setting (MAX Speed) determines the fastest motor speed allowable when the main speed pot (or reference voltage) is at 100%. With this adjustment, we can overspeed the motor slightly, or we can limit the speed below the motor's maximum speed rating. The MAX speed trimpot is especially useful when we cannot obtain the exact motor for our desired speed. Simply use one that can go faster, and reduce the maximum speed setting during calibration.

### ADJUSTABLE ACCELERATION & DECELERATION

These settings are often referred to as soft start and soft stop. They are useful in applications that require the motor to ramp up to set speed, and ramp down to a slower speed; a filling machine conveyor is a good example. Here we don't want liquid in the containers to spill because of abrupt changes in speed. These trimpots are also useful in applications using an undersized motor due to space constraints (centrifuges for example). A very slow acceleration helps to avoid going into current limit as the motor accelerates to set speed.

Turning the acceleration or deceleration trimpot clockwise will lengthen the time it takes for the speed change to occur.

Single quadrant drives can not stop the motor any faster than a coast. If quick stopping is needed then use a regenerative drive.

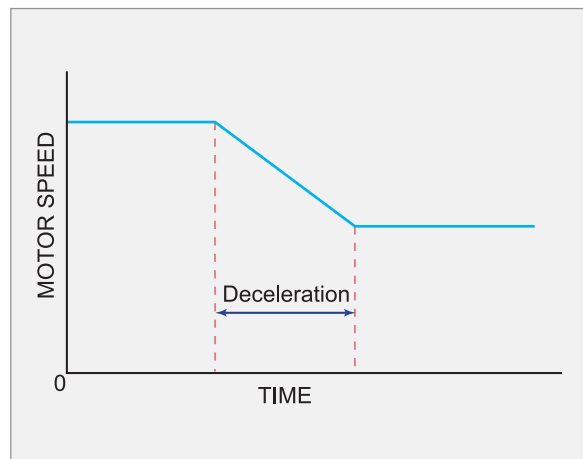
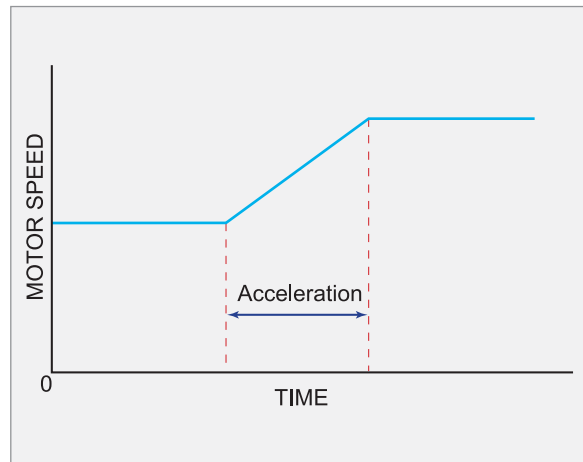

## DYNAMIC BRAKING

Minarik always recommends regenerative drives when applications require fast, contactorless braking and reversing. Even when reversing is not fast or frequent, regenerative drives may still be the most long term economical solution. However, certain situations may call for another method known as dynamic braking and reversing. This method uses a relay or switch rated for motor current, and a properly sized resistor. The brake resistor converts the energy of the load into thermal energy in the brake resistor. A smaller Ohm rating of the resistor means faster stopping. Minarik recommends starting with a 40 Ohm, 40 Watt resistor. It is always recommended that the armature be disconnected only when the drive's output voltage is zero.

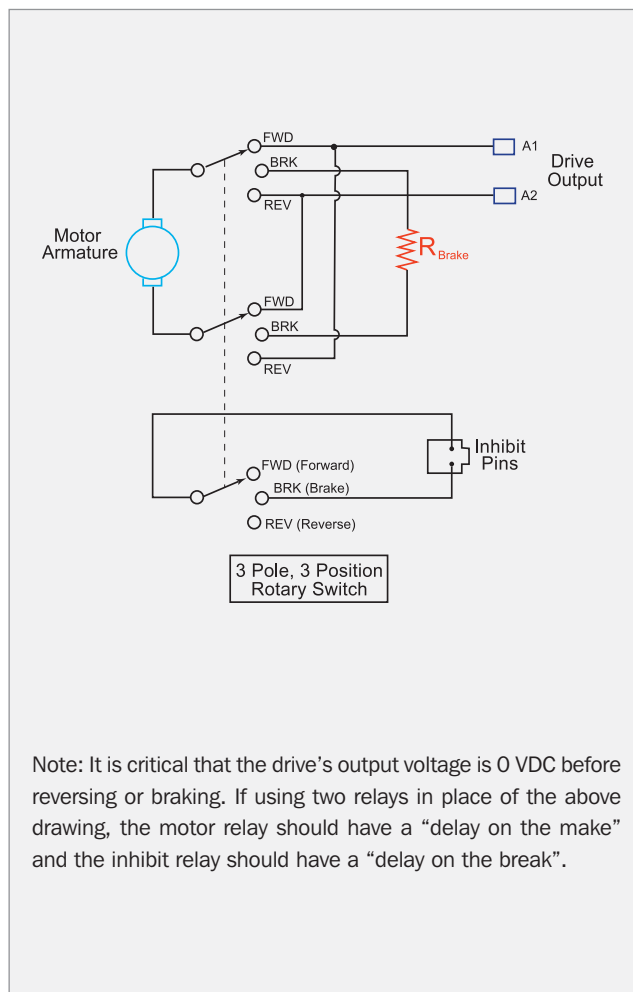

## INHIBIT

Depending on the application, users may want to ramp their motor down slowly (decelerate), while others may need to stop more quickly. For rapid or frequent motor stopping capability, most applications require regenerative drives. However, typical Minarik drives contain inhibit circuitry. Inhibiting a drive causes the output voltage to fall to zero or to a level determined by the minimum speed trimpot.

Inhibiting occurs by closing a switch on most drives, and opening a switch on others. Inhibiting single-quadrant drives simply reduces the drive output to zero (or a calibrated minimum voltage) which allows the motor and its load to coast. The drive applies no braking torque, rather the system friction provides the retarding forces. Inhibit bypasses the decel setting for "coast-to-stop". Opening the inhibit switch allows the motor to accelerate smoothly to its set speed.

In four-quadrant (regenerative) drives, shorting the inhibit terminals will regeneratively brake the motor. It bypasses both the minimum speed and the deceleration settings for rapid braking determined by the torque trimpot setting. Depending on the drive wiring scheme, users can regeneratively brake a motor (following the deceleration setting) to a stop, decelerate the motor to minimum speed, or coast the motor to a stop (without removing power) by shorting the INHIBIT-RUN terminals.

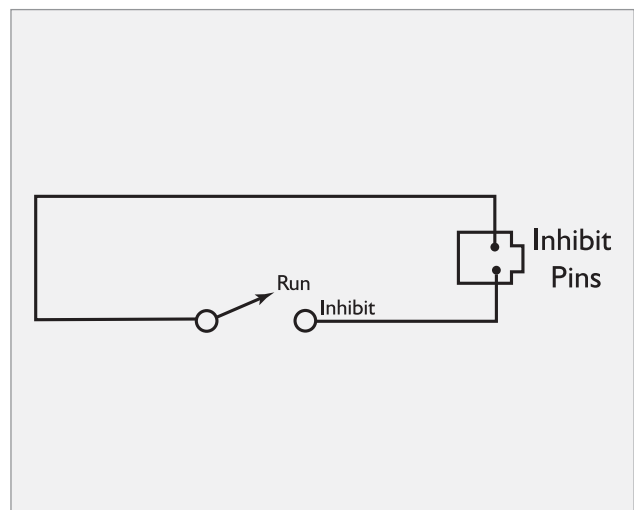

**ISOLATION**

Motor windings are simply coils of wire separated by insulating material. Only the base and outside of the motor is touching “earth ground.” The drives use one of the wires coming from these motor coils as “common”. Common is the point in the control circuit from which all other internal voltages are referenced. This part of the motor coil is the drive’s zero reference.

Common and earth ground are at a high voltage potential from each other, typically equal to the line voltage. If we plugged a drive into a 115 VAC line socket, and measured the voltage from the drive’s common to earth ground, we would see about 115 VAC. We say the drive floats above ground since these two points have a very large potential difference.

Often control signals from an external source (such as a PLC or transducer) are referenced to earth ground. If we set a grounded 0-10 VDC analog signal to 0 VDC, and measure from that point to earth ground, we would see “0 VDC”. An attempt to connect this source directly into the drive would result in catastrophic failure of the signal source and/or the drive. Therefore, we must use a device that provides good electrical isolation between these two points. An isolation device takes the incoming voltage from the signal source, and makes an “image” of this voltage, but isolated, for the drive to use as the reference. The output voltage is isolated from the ground and safe to wire to the drive.

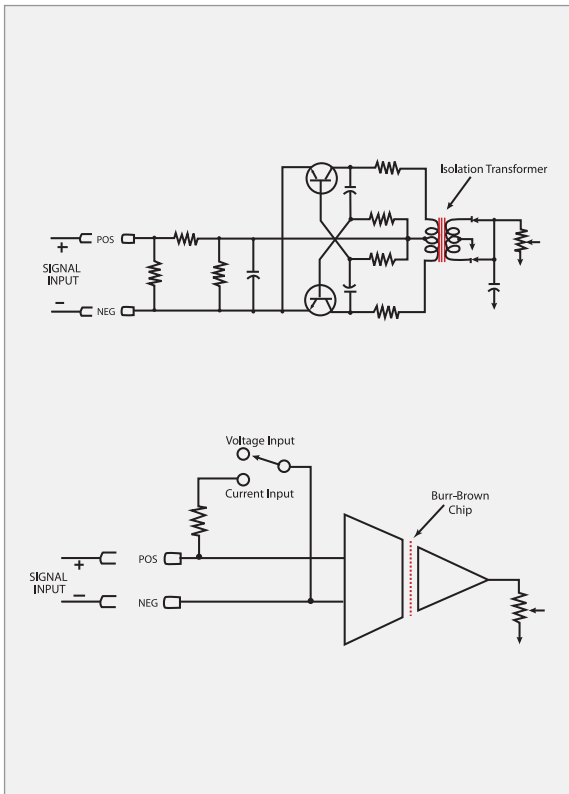

There are two basic methods of isolation used by Minarik:

**1. ISOLATION TRANSFORMERS**

Minarik uses a simple push-pull transistor pair to transform an external DC signal into square-wave AC. Since transformers can only transmit AC, the DC signal from the remote source must be “sampled” into AC. Then, the signal goes through a 1:1 isolation transformer; subsequently, a bridge rectifier converts it back into DC. This method is 2 to 3 times more linear than an opto-coupled device, but voltage drops still exist across the transistors and diode bridge. Our PCM20000 and PCMPX drives use this method.

**2. BURR-BROWN ISO CHIP**

This is Minarik’s most reliable method of isolation. The Integrated Circuit (IC) uses a uniquely isolated op-amp, with feedback for excellent linearity. It is 300 times more linear than the opto-coupler and has better isolation than the other devices. More complex, the Burr-Brown IC requires support circuitry to run. Minarik provides separate isolation modules to use with any motor drive, or with isolation directly integrated into a drive. Minarik’s PCM4 isolation module, PCM adder card, RG5500U, MM300, and MM-PCM among many other drives use this method.

## SIZING AN ENCLOSURE

There are numerous issues to consider when sizing an enclosure for a drive: motor nameplate rating, type of material, style and appearance, environment, and internal volume of the drive. Two things affect the internal volume; first, the amount of depth for safe clearance of components mounted inside of the enclosure; second, the amount of volume necessary to dissipate the heat generated by the drive. We either dissipate heat through a heatsinking device (similar to an aluminum back plane), or by letting it flow out to the “ambient” air. If there is sufficient aluminum in the enclosure’s back plane, then the internal volume may be smaller.

However, if using a plastic or steel enclosure, where little or no back-plane exists to dissipate heat from the drive, then you will need to use forced air ventilation, or a larger volume inside the enclosure to dissipate the heat into the “ambient” air.

Most enclosure manufacturers use computers to quickly answer your questions and recommend the correct size enclosure for your drive.

### DEPTH

All Minarik’s SCR drives require at least 1” of clearance at the top point of the drive. Filtered PWM drives (due to bus capacitors) require at least 2” clearance from the top. When mounting anything into the lid, remember to make accommodations in the depth behind the lid for components like switches and potentiometers.

### HEAT DISSIPATION

Unfiltered SCR drives are typically 96% efficient, while filtered PWM drives are typically 94% efficient. We calculate the heat dissipation by multiplying the power output to the motor measured in watts (1 HP motor at full load = 746 watts) by the inefficiency of the drive (0.04 for SCR drives or 0.06 for PWM drives).

## ENCLOSURE STANDARDS

for non-hazardous locations

Standard NEMA (IEC)*	Indoors	Outdoors	Accidental bodily contact	Falling dirt	Dust, lint, fibers (non-volatile)	Windblown dust	Falling liquid, light splash	Indirect hosedown & heavy splash	Rain, snow & sleet	Oil or coolant seepage	Oil or coolant spray & splash	Corrosion Resistant
NEMA 1 (IP10)	x		x	x								
NEMA 3 (IP54)	x	x	x	x	x		x			x	x	
NEMA 4 (IP56)	x	x	x	x	x	x	x	x	x			
NEMA 4X (IP56)	x	x	x	x	x	x	x	x	x			x
NEMA 12 (IP52)	x		x	x	x		x					
NEMA 13 (IP54)	x		x	x	x		x			x	x	

\*The IEC equivalents listed in this column are approximate. NEMA types meet or exceed the test requirements for the associated IEC classifications.

1st DIGIT	Protection against foreign objects	2nd DIGIT	Portection against moisture
0	Not protected	0	Not protected
1	Protected against objects > 50 mm	1	Protected against dipping water
2	Protected against objects > 12 mm	2	Protected against dripping water when tilted up to 15N
3	Protected against objects > 2.5 mm	3	Protected against spraying water
4	Protected against objects > 1.0 mm	4	Protected against splashing water
5	Dust protected	5	Protected against water jets
6	Dust tight	6	Protected against heavy seas
	-----	7	Protection against the effects of immersion
	-----	8	Protection against submersion

**FORM FACTOR**

Form factor is a figure that indicates how much the current departs from pure DC. Mathematically, form factor is the quotient of RMS current and average (AVG) current:

$$\frac{\text{RMS Current (AC)}}{\text{AVG Current (DC)}}$$

G

Unity form factor represents pure DC. Values greater than one indicate increasing departure from pure DC. The practical effects of larger form factor input into a motor include increased heating, decreased brush life, and diminished motor and system efficiency. The form factor rating of a motor defines the maximum form factor for which the stated motor ratings apply. The output form factor of the drive should never exceed the form factor rating of the motor.

An unfiltered SCR drive output is not a fully rectified sine wave at maximum speed. Form factors of approximately 1.37 are typical for an unfiltered SCR drive operating at full speed. At lower speeds, the form factor of the armature output increases. The published form factor rating of an SCR drive indicates only its best (lowest) form factor value.

The form factor of PWM drives does not exceed 1.05, nor does it deteriorate as speed reduces. The form factor rating of PWM drives is valid over the entire speed range, which accounts for the larger speed range of PWM drives. The low form factor can be a substantial system advantage over SCR drives in terms of efficiency of operation and lower maintenance costs.

**CALIBRATION REVIEW**

The following section reviews calibration of most single quadrant drives. Four quadrant drives use similar calibration techniques, but for two directions.

**MIN SPD**

The MIN SPD setting determines the motor speed when the speed adjust potentiometer is turned full CCW. It is factory set to zero speed.

Use the following procedure to set MIN SPD:

1. Set the speed adjust potentiometer full CCW.
2. Adjust the MIN SPD trimpot until the motor has stopped (for zero speed setting), or is running at the desired minimum speed.

**MAX SPD**

The MAX SPD setting determines the motor speed when the speed adjust potentiometer is turned full CW. It is factory set for maximum rated voltage.

Use the following procedure to set MAX SPD:

1. Set the speed adjust potentiometer full CW.
2. Adjust the MAX SPD trimpot until the motor is running at the desired maximum speed.

**TORQUE (CURRENT LIMIT)**

The TORQUE setting determines the maximum torque for accelerating and driving the motor.

Use the following procedure to set TORQUE:

1. With power disconnected from the drive, connect a DC ammeter in series with the armature.
2. Set the TORQUE trimpot to minimum (full CCW)
3. Set the speed adjust potentiometer to maximum speed (full CW).
4. Carefully lock the motor armature. Be sure that the motor is firmly mounted.
5. Apply line power. The motor should be stopped.
6. Slowly adjust the TORQUE trimpot CW slowly until



## CALIBRATION REVIEW

the armature current is 150% of motor rated armature current.

7. Turn the speed adjust potentiometer CCW until the motor stops.
8. Remove the line power.
9. Remove the stall from the motor.
10. Remove the ammeter in series with the motor armature if it is no longer needed.

### IR COMP

The IR COMP trimpot setting determines the degree to which motor speed is held constant as the motor load changes.

Use the following procedure to recalibrate the IR COMP setting:

1. Turn the IR COMP trimpot to full CCW.
2. Set the speed adjust potentiometer until the motor runs at midspeed without load (for example, 900 RPM for an 1800 RPM motor). A hand held tachometer may be used to measure motor speed.
3. Load the motor armature to its full load armature current rating. The motor should slow down.
4. While keeping the load on the motor, rotate the IR COMP trimpot CW until the motor runs at the speed measured in step 2. If the motor does not maintain set speed as the load changes, gradually rotate the IR COMP trimpot CW. If the motor oscillates (over compensation), the IR COMP trimpot may be set too high (CW). Turn the IR COMP trimpot CCW to stabilize the motor speed.
5. Unload the motor.

### ACCEL

The ACCEL setting determines the time the motor takes to ramp to a higher speed. See User Manual for approximate acceleration times. ACCEL is factory set for the fastest acceleration time (full CCW).

Use the following procedure to set acceleration time:

## CALIBRATION REVIEW

1. Set the speed adjust potentiometer full CCW. The motor should run at a minimum speed.
2. Turn the speed adjust potentiometer to full CW and measure the time it takes for the motor to go from minimum to maximum speed.
3. If the time measured in step 2 is not the desired acceleration time, turn the ACCEL trimpot CW for a slower acceleration time, or CCW for a faster acceleration time. Repeat steps 1 through 3 until acceleration time is correct.





### DECEL

The DECEL setting determines the time the motor takes to ramp to a lower speed. See User Manual for approximate deceleration times. DECEL is factory set for the fastest deceleration time (full CCW).





Use the following procedure to set the deceleration time:

1. Set the speed adjust potentiometer full CW. The motor should run at maximum speed.
2. Turn the speed adjust potentiometer to full CCW and measure the time it takes the motor to go from maximum to minimum speed.
3. If the time measured in step 2 is not the desired deceleration time, turn the DECEL trimpot CW for a slower deceleration time, or CCW for a faster deceleration time. Repeat steps 1 through 3 until the deceleration time is correct.

## Agency Approvals

PART NUMBER	PAGE #	UL RECOGNIZED 	UL LISTED 	CSA 	CE 
MM23011C	4	Y	Y	Y	Y
MM23111C	4	Y	Y	Y	Y
MM23211C	4	Y	Y	Y	Y
MM23411C	4	Y	Y	Y	Y
MM23001C	4	Y	Y	Y	Y
MM23101C	4	Y	Y	Y	Y
MM23201C	4	Y	Y	Y	Y
MM23401C	4	Y	Y	Y	Y
MM23012D	5	Y	Y	Y	Y
MM23112D	5	Y	Y	Y	Y
MM23212D	5	Y	Y	Y	Y
MM23412D	5	Y	Y	Y	Y
MM23002D	5	Y	Y	Y	Y
MM23102D	5	Y	Y	Y	Y
MM23202D	5	Y	Y	Y	Y
MM23402D	5	Y	Y	Y	Y
M1	6	Y	Y	-	-
M2	7	Y	Y	-	-
M2-D	7	Y	Y	-	-
PCM21010A	8	Y	-	Y	Y
PCM23411A	8	-	-	-	Y
PCM21000A	8	Y	-	Y	Y
PCM22000A	8	Y	-	Y	Y
PCM23001A	8	Y	-	Y	Y
PCM23401A	8	Y	-	Y	Y
MM311U	9	Y	Y	Y	Y
MM301U	9	Y	Y	Y	Y
MM501U	9	Y	Y	-	-
MM03-115AC-PCM	10	Y	Y	-	Y
MM03-230AC-PCM	10	Y	Y	-	Y
MM10-115AC-PCM	10	Y	Y	-	Y
MM10-230AC-PCM	10	Y	Y	-	Y
MM31701B	11	-	-	-	-
MM31751B	11	-	-	-	-
MM31700B	11	-	-	-	-
MM31750B	11	-	-	-	-
RD16U	11	-	-	-	-
SQ16U	11	-	-	-	-
SQ216U	11	-	-	-	-
MC10	12	Y	Y	-	-
MC10-PCM	12	Y	Y	-	-
MC10-R	12	Y	Y	-	-
MMXL02-D240AC	13	Y	-	Y	Y
MMXL02-D240AC-PCM	13	Y	-	Y	Y
MMXL05-D240AC	13	Y	-	Y	Y
MMXL05-D240AC-PCM	13	Y	-	Y	Y
MMXL10-D240AC	13	Y	-	Y	Y
MMXL10-D240AC-PCM	13	Y	-	Y	Y
XL3025A	14	Y	-	Y	Y
C4XL3025	14	-	-	-	Y
XL3050A	14	Y	-	-	Y
XL3200A	14	Y	-	Y	Y
C4XL3200A	14	-	-	-	Y
XL3300A	14	-	-	-	Y
C1XP01-115AC-A	15	Y	-	Y	Y
XP02-115AC	15	Y	-	Y	-
XP02-115AC-Q	15	-	-	Y	-
PCMXP02-115AC	15	Y	-	Y	-
C1XP03-115AC-A	15	Y	-	Y	Y
XP05-115AC	15	Y	-	Y	-
PCMXP05-115AC	15	Y	-	Y	-

Y = YES, - = NO, P = PENDING

PART NUMBER	PAGE #	UL RECOGNIZED 	CUL LISTED 	CSA 	CE 
XP10-115AC	15	Y	-	Y	-
PCMP10-115AC	15	Y	-	Y	-
HTL05-D-4Q	16	Y	Y	-	-
DC1.5-12	17	-	-	-	-
DC1.5-24	17	-	-	-	-
LV01-24AC	18	Y	Y	-	Y
LV02-24AC	18	Y	Y	-	Y
LV02-24DC	18	Y	Y	-	Y
DC16-12/24	19	Y	Y	-	-
DC30-12/24-4Q	20	-	-	-	-
DC60-12/24	19	Y	Y	-	-
DC60-36/48	19	Y	Y	-	-
DC250-12/24-4Q	21	-	-	-	-
DC240-36/48-4Q	21	-	-	-	-
DC500N-4Q-36/48	22	-	-	-	-
RG510UA	23	Y	Y	Y	Y
RG510UA-PCM	23	Y	Y	Y	Y
RG510A	23	Y	Y	Y	Y
RG500UA	23	Y	Y	Y	Y
RG500UA-PCM	23	Y	Y	Y	Y
RG500A	23	Y	Y	Y	Y
RG511A	24	Y	Y	Y	Y
RG501A	24	Y	Y	-	-
RG61U	25	Y	Y	-	-
RG61U-PCM	25	Y	Y	-	-
RG60U	25	Y	Y	-	-
RG60U-PCM	25	Y	Y	-	-
RG5500U	26	Y	Y	-	-
NRG02-D240AC-4Q	27	Y	Y	-	Y
NRG02-D240AC-4Q-PCM	27	Y	Y	-	Y
NRG05-D240AC-4Q	27	Y	Y	-	Y
NRG05-D240AC-4Q-PCM	27	Y	Y	-	Y
NRG10-115AC-4Q	27	Y	Y	-	Y
NRG10-115AC-4Q-PCM	27	Y	Y	-	Y
TA10-D	34	P	P	-	-
VFD02-115AC	35	Y	Y	-	-
VFD02-230AC	35	Y	Y	-	-
VFD02-D230AC	35	Y	Y	-	-
VFD04-115AC	35	Y	Y	-	-
VFD04-230AC	35	Y	Y	-	-
VFD04-D230AC	35	Y	Y	-	-
VFDA4X04-D230-PCM	36	Y	Y	-	-
VDF4X04-D230-PCM	36	Y	Y	-	-
VDFP4X04-D230-PCM	36	Y	Y	-	-
VFD05-D230-PCM	36	Y	Y	-	-
VFDS4X05-D230-PCM	36	Y	Y	-	-
ACM100 SERIES	37	Y	Y	-	-
AC200 SERIES	38	Y	Y	-	-
AC300 SERIES	40	Y	Y	-	-
DLC600	42	Y	-	-	Y
VT8-D230AC	43	Y	-	Y	Y
PCM4	45	Y	-	Y	Y
200-0386A	45	-	-	-	-

Y = YES, - = NO, P = PENDING

**Acceleration/Deceleration** The time rate of change in velocity; acceleration refers to an increase in velocity, while deceleration refers to a decrease in velocity. Generally expressed as radians/sec/sec. Board-mounted trimmer potentiometers let users adjust the time it takes for the motor to reach set speed.

**Actuator** A device that converts various forms of energy, when given an input, to rotating or linear mechanical motion such as a motor.

**Air-Gap** The area between the rotating and stationary members of an electric motor.

**Alternating Current (AC)** Electrical current flow, usually generated by the utilities at 60 Hz, which continuously reverses direction in the middle of its cycle. Mathematically, it follows a sine wave; it travels from zero, then reaches a maximum in one direction, decreases to zero, then reverses to reach a maximum in the opposite direction.

**Ambient Temperature** The temperature of the medium, usually air, around a device such as a motor or drive.

**Ampere (AMP)** The standard unit of electrical current, or rate of electron flow. A closed-loop electrical circuit with one volt of potential difference across one Ohm of resistance causes one ampere of current to flow.

**Armature** The armature is the rotating member of an electric motor. In brush-type DC motors, it consists of the main current carrying windings (conductors). The commutator switches the power supply to the armature windings to generate a magnetic field.

**Back-Emf** Also known as counter emf (cemf), it is the voltage produced across motor windings, due to the winding turns being cut by a magnetic field, during rotation of the motor. The back-emf is directly proportional to rotor velocity and opposite in polarity to the applied voltage. This static voltage arises from the generator action in a motor, even if the motor windings are not energized.

**Backlash** In a mechanical system, backlash is the relative motion between two devices, connected by a coupler, gear, screw, etc.

**Bridge Rectifier** A section of the DC drive that converts the AC power supply into a DC source.

**Brushes** The current conducting material, usually carbon or graphite, which rests directly on the commutator of brush-type DC motor. They transmit current from the power supply to the armature.

**Capacitor** A device which holds electrical charge for a period of time, prevents the flow of direct current and allows the flow of alternating current. These components serve as filters in DC drives to provide a “cleaner” DC signal to the motor.

**Chassis** Open construction of a drive for mounting within a customer's existing enclosure or control console.

**Choke** A filter device consisting of an inductor and a resistor. Although more expensive than a typical RC filter, they exhibit better performance.

**Closed-loop** A system that uses feedback information to regulate the output response. The output feeds back to a controller for comparison to the input command; any difference results in a corresponding change in the input command. Thus, the accuracy increases.

**Cogging** Cogging refers to shaft rotation occurring in jerks or increments rather than smooth continuous motion. The non-uniform (“jerky”) rotation results from the armature's propensity to certain discrete angular positions. The interaction of the armature coils entering and leaving magnetic fields, produced by the field coils or permanent magnets, causes speed changes. The armature tends to speed up and slow down as it cuts through the fields during rotation. Cogging is very apparent at low speeds, and determines a motor's speed range.

**Commutator** A device mounted on the armature shaft and consisting of a number of wedge shaped copper segments arranged around the shaft. These segments are insulated from the shaft and from each other. The motor brushes ride on the periphery of the commutator, and electrically connect and switch the armature coils to the power source.

**Conductor** Any material, such as copper or aluminum, which offers little resistance to the flow of electric current.

**Current Limit (Torque Limit)** This feature permits the operator to adjust the maximum current the motor can draw. This, in effect, limits the maximum torque the motor will produce.

**Dynamic Braking** A way of quickly stopping a motor by disconnecting the power source. The rotating motor then becomes a generator. When connected to a resistor, the energy of rotation is then dissipated as heat in the resistor.

**Duty Cycle** The ratio of operating time versus total cycle time of a motor. A motor has a continuous duty rating if it continues to operate for an indefinite amount of time and its normal operating temperature remains within the temperature limits of its insulation system. A motor has an intermittent duty rating if it never reaches a steady temperature, but is allowed to cool between operations.

**Enclosure** A description of the motor or drive housing. The selected enclosure depends on the application's environment and heat generated by the device.

**Encoder** A feedback device that translated mechanical motion into an electronic signal or combination of signals (pulses).

**Field** Motor field windings provide the magnetic field, located in the stator of DC shunt-wound motor, which interacts with the armature field to produce torque. PM motors use magnets, instead of windings, to produce the stator field.

**Filter** An electrical device used to suppress electrical noise, or to improve the DC output to a DC motor.

**Flyback Diode** This is a super fast recovery diode that snubs current and voltage spikes as a result of the fast transients that occur when IGBT, and MOSFETS are turned on and off quickly.

**Form Factor** Form factor indicates how much AC component resides in the DC output from DC drives. Represented mathematically as the ratio of a signal's root-mean square current value to its average current value. Any form factor value greater than one means that some of the current produces heat instead of torque.

**Four-quadrant** This term refers to a drive's ability to control the velocity and torque of a motor in either direction of rotation. The direction of torque can be in the opposite direction of the velocity for applications requiring braking or deceleration. Single-quadrant drives, on the other hand, only produce torque and velocity in the same direction of rotation.

**Frequency** Frequency refers to how often a complete cycle occurs in a unit of time. Frequency is usually measured in cycles per second, or Hertz, where 1 cycle/second equals 1 Hz. The standard AC power supply in the USA is 60 Hz, while 50 Hz remains common in many other countries of the world.

**Friction** The resistance to motion between surfaces.

**Fuse** A device connected to an electrical circuit designed to melt and open the circuit in the event of excess current flow.

**Gearhead** A mechanical device that converts speed and torque to values required by the application. Output torque increases, and output speed decreases proportionally to the gear ratio.

**Generator** A machine that converts mechanical energy into electric energy.

**Hall Effect Sensor** These feedback devices, commonly used in brushless motors, provide information for the amplifier to electronically commutate the motor. The sensors generate commutation signals by sensing the position of a magnetized wheel on the rotor.

**Horsepower** The rate at which work is performed. It equals the speed multiplied by torque, and a constant, depending on the units selected.

**Inductance** A property of an electric circuit that represents its ability to resist changes in current flow.

**Inertia** A function of the mass and shape of an object. The inertia represents the property of an object that resists a change in motion. An object's inertia increases directly with an increase in the object's mass; also, increasing inertia loads require more force to accelerate and decelerate them.

**Inverter (Variable Frequency Drives)** AC drive that varies the frequency and voltage applied to an AC motor to vary motor speed.

**IR Compensation** It varies the amount of voltage to the armature in response to current (load) changes. It is adjustable via a board mounted trimmer potentiometer.

**Isolated Gate Bipolar Transistor (IGBT)** A power transistor with a gate similar to the base of BJT. The difference is that the gate is electrically insulated from the collector-emitter circuit. This allows high voltages and currents to be conducted.

**Jogging** This feature provides a means of momentarily moving the motor at a different speed (normally slower) from the normal operating speed. Operators access this function using a separate control input.

**Load** A term used to describe work required from a motor to drive equipment attached to the shaft. Usually defined in units of horsepower, or torque at a certain speed.

**MOSFET** A Metal-Oxide-Semiconductor-Field-Effect-Transistor is similar to standard field-effect transistors. MOSFETs can be a N or P type. They will or will not conduct from source to drain unless a voltage is applied to the gate of the MOSFET. They have turn-on and turn-off capability, as well as fast reaction times.

**NEMA** The acronym stands for the National Electrical Manufacturers Association. The agency provides specification standards for motors and drives.

**Noise (EMI/RFI)** Electrical disturbances that interfere with proper transmission of electrical signals. Noise can have adverse effects on the system performance.

**Non-volatile Memory** A memory storage system that maintains information during the loss of power.

**Ohm** Unit of electrical resistance of a circuit in which a potential difference of one volt produces a current of one ampere.

**Open-Collector** An output signal, provided by a transistor, where the "open-collector output" acts like a switch closure to ground when activated.

**Open-Loop** A system that does not use feedback information to regulate performance.

**Phase Lock Loop (PLL)** Used for error correction, PLL refers to an external digital controller that monitors digital feedback proportional to velocity. It compares that to a known number of counts that should be seen within a specified time frame, and calculates error based on its feedback. Minarik uses Phase Lock Loop on digital front-ends such as the DLC Series.

**PLC** A programmable logic controller (PLC) uses programmed logic instructions to control banks of inputs and outputs which interface timed switch actuation to external electro-mechanical devices.

**Plugging** A method to provide quick stopping or reversing of a motor by applying partial or full reverse voltage on the motor terminals during operation. Not recommended for DC systems since the life of the motor and drive reduces, while permanent damage may result.

**Poles** The magnetic poles in an electric motor that result from connection and placement of the windings in the motor. Besides poles created by electricity, permanent magnets mounted in specific areas are poles with a constant orientation.

**Potentiometer (Pot)** A passive device (variable resistor) used to vary voltage between a minimum and maximum level. The standard speed pot is a 300° or single-turn. Operators control the speed of a motor from the potentiometer connected to a drive. Also, board-mounted trimmer pots allow users to make calibrations.

**Proportional-Integral-Derivative** The act of recognizing a velocity or position error in a system, and applying correction (or voltage change) to the system amplifier, thereby changing the motor's speed or altering position. PID refers to a group of gain parameters that tune or optimize the response of a closed-loop system.

**1. Proportional:** This feedback loop compares error and adds an equal amount of reference beyond the original. For example: with a 20% error, the loop applies 20% more than the original reference.

**2. Integral:** This loop examines the average error over a number of samples, and makes the correction associated with it. For example: with a 20% error reading in one window and 10% error in another, the integral loop may apply 15% error correction in the third window based on average of previous readings.

**3. Derivative:** This loop reads instantaneous change in error, as opposed to the error itself. It analyzes how an error differs from a previous error and adjusts accordingly. PID combines all three loops resulting in an extremely accurate form of digital error correction. Each loop checks and balances the other to assure the right amount of error correction. Lead-Lag is similar to PI in correcting error through known error and average error. The difference is that this can over or under compensate, based on a trend or assumption of what is assumed will occur in the next error. The error correction can lead or lag the actual error.

**Rated Values** The rated value of a parameter (voltage, temp, etc.) is the maximum value that the parameter can reach in an electric device operating continuously without undue degradation, loss of its basic properties, or safety hazards.

**Regenerative** Regenerative drives, often used interchangeably with four quadrant drives, applies to the regeneration of energy from the motor and drive, back to the power source. A motor generates when the load forces the motor to go faster than the drive has set. Four quadrant drives can prevent motors from over speeding. A four quadrant drive is regenerative when it puts the generated energy back into the source, like a battery or the AC line. Also, the energy could be dumped across a dynamic brake resistor or a dump resistor, as is the case in a non-regenerative, four quadrant drive.

**Relay** These electronic components control other devices in a circuit. A set of contacts, the switching mechanism, open or close when the relay's magnetic coil becomes energized.

**Resistance** The opposition to current flow through a conductor in a closed circuit.

**Rotor** The rotating assembly of a motor. Usually includes a shaft, fan and rotor core.

**Silicon Controlled Rectifier (SCR)** Also known as a thyristor, a SCR is basically a diode with an extra junction tied to a third leg, known as the gate between the cathode and anode. SCRs prevent current flow in either direction until the gate receives a voltage signal. After receiving this trigger signal, the SCR then becomes a diode. It remains on, regardless of what happens at the gate, until the zero crossing, at which point current ceases to flow.

**Servo** A system consisting of an amplifier, actuator, and feedback element. Servos tend to control one or combination of the following variables: position, velocity and torque.

**Speed Regulation** Defined as the deviation in motor speed from No Load to Full Load; usually expressed as a percentage of base speed. Feedback devices, like a tachometer or digital closed loop control, provide increased regulation.

**Stator** The stationary part of a motor. A PM DC motor holds its magnets in the stator.

**Surge Suppressors** These devices, like a metal oxide varistor (MOV), suppress voltage transients that can occur on the AC line.

**Tachometer Feedback** A tachometer (tach) generates a voltage proportional to speed. Tachs provide a closed-loop system with excellent speed regulation.

**Torque** A rotational force equal to an equivalent linear force applied at a right angle to a radius of  $r$ .

**Torque-to-Inertia Ratio** The rated motor torque divided by its rotor inertia. Helps determine a motor's ability to accelerate loads.

**Transformer** A passive device that raises or lowers AC voltage by induction.

**TTL (Transistor-Transistor Logic)** A popular family of integrated circuit devices that operate from logic level voltages, 5 to 12 VDC.

**Voltage** Voltage is electric pressure. A volt is a unit of electromotive force which causes 1 Amp of current to flow through a 1 Ohm resistor.

**Watts** The power required to maintain one ampere of current at a pressure of one volt when the two components are in phase with each other. A unit of horsepower is equal to 746 watts.

Cross Reference

G

OLD MODELS	NEW MODELS	FOOT-NOTES
AC75	No longer available	#1
AC100	No longer available	#1
AC200	No longer available	#1
BC90	No longer available	#1
BC90UD4	MM23001C	
BC290	MM23101C	
BC290UD4	MM23001C	
BC2110UD4	MM501U	
BC2150UD4	MM501U	
BCT198UD4	No longer available	#1
BCT2150UD4	No longer available	#1
C80U	MM23001C	#1
C85U	MM23001C	
C280U	MM23001C	
C285U	MM23001C	
DLC120	DLC600	#5
DLC240	DLC600	#5
DLC300	DLC600	#5
DLC300-SPEC.0404	DLC600	#5
DLC400	DLC600	#5
DLC400-SPEC.0404	DLC600	#5
DLC500	DLC600	#5
E10U	No longer available	#1
E15U	MM31610A	#5
E16U	MM31610A	#5
E50U	MM23001C	#5
E51U	MM23001C	#5
E250U	MM23001C	#5
E251U	MM23001C	#5
FDC30	No longer available	#1
M3U	XP01-115AC-SL	
M3UD2	XP01-115AC-SL	
M6	MM21151C	
M6UD1	XL3025A	
M6UD2	XL3025A	
M6UD3	XL3025A	
M6UD4	XL3025A	
M14	MM21151C	
M14UD1	XL3025A	
M14UD2	XL3025A	
M14UD3	XL3025A	
M14UD4	XL3025A	
M26UD1	XL3025A	
M26UD2	XL2035A	
M26UD3	XL3025A	
M26UD4	XL3025A	
M35	MM23101C	
M60	MM23101C	
M90	MM23101C	
M230	MM23101C	
M250	MM23101C	
M260	MM23101C	
M290	MM23101C	
MB653U	RD16U	
MM50	MM23111C	#2
MM50U	MM311U	#2
MM51	MM23111C	#2
MM51U	MM311U	#2
MM100	MM23401C	#5
MM100U	MM301U	#5
MM101	MM23401C	#5
MM101U	MM301U	#5
MM200	MM23401C	#5

OLD MODELS	NEW MODELS	FOOT-NOTES
MM201	MM23401C	#5
MM201U	MM301U	#3, #5
MM2111A	MM23111C	#5
MM21211A	MM23211C	#5
MM23001C-H	MM23001C-Q	#5
MM23101A	MM23101C	#5
MM23201A	MM23201C	#5
MM23401A	MM23401C	#5
MM23411A	MM23411C	#5
MM23021A	XL3300A or MM501U	#5
MM31002A	MM23001C	#5
MM31700A	MM31700B	#5
MM31701A	MM31701B	#5
MM31750A	MM31750B	#5
MM31751A	MM31751B	#5
MMR50	MM21211A or RG510A	#2
MMR51	MM21211A or RG510A	#2
MMR100	RG500A	#5
MMR101	RG500A	#5
MMR200	RG500A	#5
MMR201	RG500A	#5
MMR35	MM23201C	
MMR60	MM23201C	
MMR90	MM23201C	
MMR230	MM23201C	
MMR250	MM23201C	
MMR260	MM23201C	
MMR290	MM23201C	
MR6	MM21251C	
MR14	MM21251C	
N80	MM23401C	
N280	MM23401C	
NR80	RG500A	
NR280	RG500A	
PCM1	PCM4	
PCM2	PCM4	
PCS1	PCM4	
PCS2	PCM4	
PK3	PK15 OR PK17	
PK4	PK16	
RC115	No longer available	#1
RC230	No longer available	#1
RG50	RG510A	#2
RG50U	RG51UA or RG500UA	
RG51U	RG51UA or RG500UA	
RG101UC	RG101UD	#5
RG201UC	RG201UD	#5
RG100UA	RG100UC or RG500UA	
RG100UB	RG100UC or RG500UA	
RG101UA	RG101UD	#5
RG101UB	RG101UD	#5
RG102UA	No longer available	#1
RG200UA	RG200UC OR RG500UA	
RG200UB	RG200UC OR RG500UA	
RG201UA	RG201UD	#5
RG201UB	RG210UD	#5
RG202UA	No longer available	#1
RG300A	RG500A	#5
RG300UA-PCM	RG500UA-PCM	#5
RG310UA	RG510UA	#5
RG310UA-PCM	RG510UA-PCM	#5
RG400A	RG500A	#5
RG400UA	RG500UA	#5

OLD MODELS	NEW MODELS	FOOT-NOTES
RG400UA-PCM	RG500UA-PCM	#5
RG300UA	RG500UA	
SH12	SL15	
SH12FB	SL15	
SH14	SL15	
SH32	MM21251C	
SH32FB	MM21251C	
SH33	MM21251C	
SH52	MM21251C	
SH52FB	MM21251C	
SH53	MM21251C	
SH63	MM21251C	
SH73	No longer available	#1
SH83	No longer available	#1
SH273	No longer available	#1
SH283	No longer available	#1
SH293	No longer available	#1
SL10U	XP01-115AC-SL	#5
SL14	SL15	
SL14P	No longer available	#1
SL15U	XP01-115AC-SL	#5
SL31UD1	XL3025A	
SL31UD2	XL3025A	
SL31UD3	XL3025A	
SL31UD4	XL3025A	#5
SL32	MM21251C	#4, #5
SL51UD1	XL3025A	
SL51UD2	XL3025A	
SL51UD3	XL3025A	
SL51UD4	XL3025A	#5
SL52	MM21251C	#4, #5
SL58	MM21251C	
SL58U	XL3025A	
SL61	MM21151C	
SL61UD1	XL3025A	
SL61UD2	XL3025A	
SL61UD3	XL3025A	
SL61UD4	XL3025A	
SL63	MM21251C	
SLF38	MM21251C	
SLF38UD4	XL3025A	
SLF58	MM21251C	
SLF58UD4	XL3025A	
SLF61	MM21151C	
SLF63	MM21151C	
SLF67	MM21151C	
SLF68	MM21151C	
SLF68UD4	XL3025A	
SLF69	MM21151C	
SLF70	MM21251C	
SLF88	No longer available	#1
SLF88XF	No longer available	#1
SLF298	No longer available	#1
SLT18UD4	No longer available	#1
SLT38UD4	No longer available	#1

OLD MODELS	NEW MODELS	FOOT-NOTES
SLT58UD4	No longer available	#1
SLT68UD4	No longer available	#1
SLT78UD4	No longer available	#1
SLT298UD4	No longer available	#1
SSR21010A	RG500UA	
SSR21000A	RG500UA	
SSR22000A	RG500UA	
TA100P	TA101P	#5
TR9020U	No longer available	#1
VT2-115	VT8-D230AC	#5
VT3-230	VT8-D230AC	#5
VT6-115	VT8-D230AC	#5
VT6-230	VT8-D230AC	#5
W12	No longer available	#1
214	No longer available	#1
232	MM21251C	
W33	No longer available	#1
W52	MM21251C	
W53	No longer available	#1
W63	No longer available	#1
W63RM	No longer available	#1
W73	No longer available	#1
W83	No longer available	#1
W203	No longer available	#1
W273	No longer available	#1
W283	No longer available	#1
W293	No longer available	#1
WP10	No longer available	#1
WP11	No longer available	#1
WP12	No longer available	#1
WP15	No longer available	#1
WP20	No longer available	#1
WP21	No longer available	#1
WP24	No longer available	#1
WP25	No longer available	#1
WP32	No longer available	#1
WP50	No longer available	#1
WP51	No longer available	#1
WP52	No longer available	#1
WP54	No longer available	#1
WP55	No longer available	#1
WP6001	No longer available	#1
WP6011	WP6211	#5
WP6012	WP6212	#5
WP6020	No longer available	#1
WP6023	No longer available	#1
WP6040	No longer available	#1
WP6101	WP6201	#5
WP6111	WP6211	#5
WP6120	No longer available	#1
WP1233	No longer available	#1
WP1253LP	XL3025A	#2
XLT2300NF	XL3300A	#5
1253	No longer available	#1
1253LP	XL3025A	#2

G

- #1. No longer available; treat as a new application.
- #2. HP ratings slightly different. Example: MM51 is designed for 1/4 HP and less; MM23111C is designed for 1/8 HP and less.
- #3. Requires heat sink attached to the control for equivalent HP ratings.
- #4. For reversible application. If unidirectional, substitute MM21151C or C4XL3025.
- #5. Footprint is exact.

PART #	DESCRIPTION	PG	PART #	DESCRIPTION	PG
032-0060	Brake resistor	46	840-010	ACM100 remote keypad	49
032-0062	Brake resistor	46	840-100	ACM100/AC200 .25-.5HP DB;208/240	48
032-0076	Brake resistor	46	840-101	ACM100/AC200 1-1.5HP DB;208/240	48
035-0007	Left-side bracket	46	840-102	ACM100/AC200 2-3HP DB;208/240	48
035-0008	Right-side bracket	46	840-103	ACM100/AC200 5HP DB;208/240	48
10EP1	Reduces control noise	47	840-104	AC200 7.5HP DB;208/240	48
110-0038	Dial	46	840-105	AC200 10HP DB;208/240	48
134-0046	DB9 male/female serial cable	46	840-106	ACM100/200 .25-.5HPDB;400/480	48
140-0009	Knob	46	840-107	ACM100/200 1-1.5HP DB;400/480	48
155-0075	Clear NEMA 4 cover	47	840-108	ACM100/200 2-3HP DB;400/480	48
200-0386A	Limit switch logic board	45	840-109	ACM100/200 5HP DB;400/480	48
201-0024	Inhibit plug	46	840-110	AC200 7.5HP DB;400/480	48
201-0079	Inhibit plug	46	840-111	AC200 10HP DB;400/480	48
201-0191	Bevel and lens	47	840-112	ACM100/AC200 1-1.5HP DB;480/590	48
202-0014	Mounting kit	47	840-113	ACM100/AC200 2-3HP DB;480/590	48
20VDK1	Filter	47	840-114	ACM100/AC200 5HP DB;480/590	48
20VR1	Filter	47	840-115	AC200 7.5HP DB;480/590	48
20VV1	Filter	47	840-116	AC200 10HP DB;480/590	48
220-0048	Bezel and lens	47	840-117	AC200 15-25HP DB module	48
220-0049	Blank bezel and lens	47	840-118	AC200 15-25HP DB module	48
220-0051	Bezel and lens	47	840-119	AC200 15-25HP DB module	48
221-0991	Mounting Bracket	32	841-006	AC300 10' Remote keypad kit	49
221-0992	Mounting Bracket	32	841-030	AC300 DB Kits	48
221-0993	Mounting Bracket	32	841-031	AC300 DB Kits	48
223-0159	Heat Sink	46	841-032	AC300 DB & add'l Form C Relays	48
223-0174	Heat Sink	46	841-033	AC300 DB & add'l Form C Relays	48
223-0235	Heat Sink	46	841-100	AC300 .5HP DB res.	48
223-0271	Heat Sink	46	841-101	AC300 1-2HP DB res.	48
506-06-131	Non-g geared motor	28	841-102	AC300 2HP DB res.	48
506-07-027	Non-g geared motor	28	841-103	AC300 3HP DB res.	48
506-07-028	Non-g geared motor	28	841-104	AC300 3HP DB res.	48
506-07-029	Non-g geared motor	28	841-105	AC300 5HP DB res.	48
506-07-030	Non-g geared motor	28	841-106	AC300 7.5&10HP DB	48
506-07-038	Non-g geared motor	28	841-107	AC300 7.5&10HP DB	48
506-37-029	Non-g geared motor	38	841-108	AC300 15&20HP DB res	48
507-01-106	In-line Geared Motor	30	841-109	AC300 15&20HP DB res	48
507-01-108	In-line Geared Motor	30	841-110	AC300 25&30HP DB res	48
507-01-109	In-line Geared Motor	30	841-111	AC300 25&30HP DB res	48
507-01-127	In-line Geared Motor	30	841-112	AC300 40HP DB res.	48
507-01-129	In-line Geared Motor	30	841-113	AC300 40HP DB res.	48
507-01-130	In-line Geared Motor	30	841-114	AC300 50&60HP DB res	48
507-01-131	In-line Geared Motor	30	841-115	AC300 50&60HP DB res	48
510-09-002	In-line Geared Motor	30	AC211S-0.75	Isolated PWM AC IP20	39
510-09-021	In-line Geared Motor	30	AC211S-1.1	Isolated PWM AC IP20	39
510-09-029	In-line Geared Motor	30	AC212B-0.2	Isolated PWM AC IP20	39
510-09-031	In-line Geared Motor	30	AC212B-0.4	Isolated PWM AC IP20	39
510-09-032	In-line Geared Motor	30	AC212B-0.75	Isolated PWM AC IP20	39
510-09-035	In-line Geared Motor	30	AC212B-1.1	Isolated PWM AC IP20	39
510-09-037	In-line Geared Motor	30	AC212B-1.5	Isolated PWM AC IP20	39
510-09-041	In-line Geared Motor	30	AC212B-2.2	Isolated PWM AC IP20	39
510-09-043	In-line Geared Motor	30	AC212B-3.7	Isolated PWM AC IP20	39
510-18-002	In-line Geared Motor	30	AC212T-0.75	Isolated PWM AC IP20	39
510-18-021	In-line Geared Motor	30	AC212T-1.1	Isolated PWM AC IP20	39
510-18-023	In-line Geared Motor	30	AC212T-1.5	Isolated PWM AC IP20	39
510-18-027	In-line Geared Motor	30	AC212T-11	Isolated PWM AC IP20	39
5VR1	Filter	47	AC212T-15	Isolated PWM AC IP20	39
6EP1	Filter	47	AC212T-2.2	Isolated PWM AC IP20	39
6VDK1	Filter	47	AC212T-3.7	Isolated PWM AC IP20	39
6VSK1	Filter	47	AC212T-5.5	Isolated PWM AC IP20	39
6VV1	Filter	47	AC212T-7.5	Isolated PWM AC IP20	39
840-004	AC200 remote keypad	49	AC214T-0.4	Isolated PWM AC IP20	39
840-005	EPM Programmer	49	AC214T-0.75	Isolated PWM AC IP20	39
840-006	10 EPM Modules	49	AC214T-1.1	Isolated PWM AC IP20	39



PART #	DESCRIPTION	PG	PART #	DESCRIPTION	PG
AC214T-2.2	Isolated PWM AC IP20	39	AC331S-0.4	Isolated PWM AC NEMA 4 & 12	41
AC214T-3.7	Isolated PWM AC IP20	39	AC331S-0.75	Isolated PWM AC NEMA 4 & 12	41
AC214T-15	Isolated PWM AC IP20	39	AC331S-1.1	Isolated PWM AC NEMA 4 & 12	41
AC214T-18.5	Isolated PWM AC IP20	39	AC332S-0.4	Isolated PWM AC NEMA 4 & 12	41
AC214T-1.5	Isolated PWM AC IP20	39	AC332S-0.75	Isolated PWM AC NEMA 4 & 12	41
AC214T-11	Isolated PWM AC IP20	39	AC332S-1.1	Isolated PWM AC NEMA 4 & 12	41
AC214T-5.5	Isolated PWM AC IP20	39	AC332S-1.5	Isolated PWM AC NEMA 4 & 12	41
AC214T-7.5	Isolated PWM AC IP20	39	AC332S-2.2	Isolated PWM AC NEMA 4 & 12	41
AC215T-0.75	Isolated PWM AC IP20	39	AC332T-0.4	Isolated PWM AC NEMA 4 & 12	41
AC215T-1.5	Isolated PWM AC IP20	39	AC332T-0.75	Isolated PWM AC NEMA 4 & 12	41
AC215T-11	Isolated PWM AC IP20	39	AC332T-1.1	Isolated PWM AC NEMA 4 & 12	41
AC215T-15	Isolated PWM AC IP20	39	AC332T-1.5	Isolated PWM AC NEMA 4 & 12	41
AC215T-18.5	Isolated PWM AC IP20	39	AC332T-11	Isolated PWM AC NEMA 4 & 12	41
AC215T-2.2	Isolated PWM AC IP20	39	AC332T-2.2	Isolated PWM AC NEMA 4 & 12	41
AC215T-3.7	Isolated PWM AC IP20	39	AC332T-3.7	Isolated PWM AC NEMA 4 & 12	41
AC215T-5.5	Isolated PWM AC IP20	39	AC332T-5.5	Isolated PWM AC NEMA 4 & 12	41
AC215T-7.5	Isolated PWM AC IP20	39	AC332T-7.5	Isolated PWM AC NEMA 4 & 12	41
AC321S-0.2	Isolated PWM AC NEMA 1	41	AC334T-0.75	Isolated PWM AC NEMA 4 & 12	41
AC321S-0.4	Isolated PWM AC NEMA 1	41	AC334T-1.5	Isolated PWM AC NEMA 4 & 12	41
AC321S-0.75	Isolated PWM AC NEMA 1	41	AC334T-11	Isolated PWM AC NEMA 4 & 12	41
AC321S-1.1	Isolated PWM AC NEMA 1	41	AC334T-15	Isolated PWM AC NEMA 4 & 12	41
AC322S-0.4	Isolated PWM AC NEMA 1	41	AC334T-2.2	Isolated PWM AC NEMA 4 & 12	41
AC322S-0.75	Isolated PWM AC NEMA 1	41	AC334T-3.7	Isolated PWM AC NEMA 4 & 12	41
AC322S-1.1	Isolated PWM AC NEMA 1	41	AC334T-5.5	Isolated PWM AC NEMA 4 & 12	41
AC322S-1.5	Isolated PWM AC NEMA 1	41	AC335T-0.75	Isolated PWM AC NEMA 4 & 12	41
AC322S-2.2	Isolated PWM AC NEMA 1	41	AC335T-1.5	Isolated PWM AC NEMA 4 & 12	41
AC322T-0.4	Isolated PWM AC NEMA 1	41	AC335T-11	Isolated PWM AC NEMA 4 & 12	41
AC322T-0.75	Isolated PWM AC NEMA 1	41	AC335T-15	Isolated PWM AC NEMA 4 & 12	41
AC322T-1.1	Isolated PWM AC NEMA 1	41	AC335T-2.2	Isolated PWM AC NEMA 4 & 12	41
AC322T-1.5	Isolated PWM AC NEMA 1	41	AC335T-3.7	Isolated PWM AC NEMA 4 & 12	41
AC322T-11	Isolated PWM AC NEMA 1	41	AC335T-5.5	Isolated PWM AC NEMA 4 & 12	41
AC322T-15	Isolated PWM AC NEMA 1	41	AC342T-15	Isolated PWM AC NEMA 4 & 12	41
AC322T-18.5	Isolated PWM AC NEMA 1	41	AC344T-18.5	Isolated PWM AC NEMA 4 & 12	41
AC322T-2.2	Isolated PWM AC NEMA 1	41	AC344T-22	Isolated PWM AC NEMA 4 & 12	41
AC322T-22	Isolated PWM AC NEMA 1	41	AC345T-18.5	Isolated PWM AC NEMA 4 & 12	41
AC322T-3.7	Isolated PWM AC NEMA 1	41	AC345T-22	Isolated PWM AC NEMA 4 & 12	41
AC322T-5.5	Isolated PWM AC NEMA 1	41	AC351S-0.2	Isolated PWM AC NEMA 4X	41
AC322T-7.5	Isolated PWM AC NEMA 1	41	AC351S-0.4	Isolated PWM AC NEMA 4X	41
AC324T-0.75	Isolated PWM AC NEMA 1	41	AC351S-0.75	Isolated PWM AC NEMA 4X	41
AC324T-1.5	Isolated PWM AC NEMA 1	41	AC351S-1.1	Isolated PWM AC NEMA 4X	41
AC324T-11	Isolated PWM AC NEMA 1	41	AC352S-0.4	Isolated PWM AC NEMA 4X	41
AC324T-15	Isolated PWM AC NEMA 1	41	AC352S-0.75	Isolated PWM AC NEMA 4X	41
AC324T-18.5	Isolated PWM AC NEMA 1	41	AC352S-1.1	Isolated PWM AC NEMA 4X	41
AC324T-2.2	Isolated PWM AC NEMA 1	41	AC352S-1.5	Isolated PWM AC NEMA 4X	41
AC324T-22	Isolated PWM AC NEMA 1	41	AC352S-2.2	Isolated PWM AC NEMA 4X	41
AC324T-3.7	Isolated PWM AC NEMA 1	41	AC352T-0.4	Isolated PWM AC NEMA 4X	41
AC324T-30	Isolated PWM AC NEMA 1	41	AC352T-0.75	Isolated PWM AC NEMA 4X	41
AC324T-37	Isolated PWM AC NEMA 1	41	AC352T-1.1	Isolated PWM AC NEMA 4X	41
AC324T-45	Isolated PWM AC NEMA 1	41	AC352T-1.5	Isolated PWM AC NEMA 4X	41
AC324T-5.5	Isolated PWM AC NEMA 1	41	AC352T-11	Isolated PWM AC NEMA 4X	41
AC325T-0.75	Isolated PWM AC NEMA 1	41	AC352T-2.2	Isolated PWM AC NEMA 4X	41
AC325T-1.5	Isolated PWM AC NEMA 1	41	AC352T-3.7	Isolated PWM AC NEMA 4X	41
AC325T-11	Isolated PWM AC NEMA 1	41	AC352T-5.5	Isolated PWM AC NEMA 4X	41
AC325T-15	Isolated PWM AC NEMA 1	41	AC352T-7.5	Isolated PWM AC NEMA 4X	41
AC325T-18.5	Isolated PWM AC NEMA 1	41	AC354T-0.75	Isolated PWM AC NEMA 4X	41
AC325T-2.2	Isolated PWM AC NEMA 1	41	AC354T-1.5	Isolated PWM AC NEMA 4X	41
AC325T-22	Isolated PWM AC NEMA 1	41	AC354T-11	Isolated PWM AC NEMA 4X	41
AC325T-3.7	Isolated PWM AC NEMA 1	41	AC354T-15	Isolated PWM AC NEMA 4X	41
AC325T-30	Isolated PWM AC NEMA 1	41	AC354T-2.2	Isolated PWM AC NEMA 4X	41
AC325T-37	Isolated PWM AC NEMA 1	41	AC354T-3.7	Isolated PWM AC NEMA 4X	41
AC325T-45	Isolated PWM AC NEMA 1	41	AC354T-5.5	Isolated PWM AC NEMA 4X	41
AC325T-5.5	Isolated PWM AC NEMA 1	41	AC355T-0.75	Isolated PWM AC NEMA 4X	41
AC331S-0.2	Isolated PWM AC NEMA 4 & 12	41	AC355T-1.5	Isolated PWM AC NEMA 4X	41

PART #	DESCRIPTION	PG	PART #	DESCRIPTION	PG
AC355T-11	Isolated PWM AC NEMA 4X	41	MM23001C	SCR Open Chassis	4
AC355T-15	Isolated PWM AC NEMA 4X	41	MM23002D	SCR Open Chassis	5
AC355T-2.2	Isolated PWM AC NEMA 4X	41	MM23011C	SCR Open Chassis	4
AC355T-3.7	Isolated PWM AC NEMA 4X	41	MM23012D	SCR Open Chassis	5
AC355T-5.5	Isolated PWM AC NEMA 4X	41	MM23101C	SCR NEMA 1 Enclosure	4
ACM110S-0.25	PWM AC IP20	37	MM23102D	SCR NEMA 1 Enclosure	5
ACM110S-0.4	PWM AC IP20	37	MM23111C	SCR NEMA 1 Enclosure	4
ACM110S-0.75	PWM AC IP20	37	MM23112D	SCR NEMA 1 Enclosure	5
ACM110S-1.1	PWM AC IP20	37	MM23201C	SCR NEMA 1 Enclosure	4
ACM112S-0.25	PWM AC IP20	37	MM23202D	SCR NEMA 1 Enclosure	5
ACM112S-0.4	PWM AC IP20	37	MM23212D	SCR NEMA 1 Enclosure	5
ACM112S-0.55	PWM AC IP20	37	MM23401C	SCR NEMA 4X Enclosure	4
ACM112S-0.75	PWM AC IP20	37	MM23402D	SCR NEMA 4X Enclosure	5
ACM112S-1.1	PWM AC IP20	37	MM23411C	SCR NEMA 4X Enclosure	4
ACM112S-1.5	PWM AC IP20	37	MM23412D	SCR NEMA 4X Enclosure	5
ACM112S-2.2	PWM AC IP20	37	MM301U	SCR Isolated Open Chassis	9
ACM112T-0.4	PWM AC IP20	37	MM311U	SCR Isolated Open Chassis	9
ACM112T-0.75	PWM AC IP20	37	MM31700B	SCR Open Chassis	11
ACM112T-1.1	PWM AC IP20	37	MM31701B	SCR Open Chassis	11
ACM112T-1.5	PWM AC IP20	37	MM31750B	SCR Open Chassis	11
ACM112T-2.2	PWM AC IP20	37	MM31751B	SCR Open Chassis	11
ACM112T-3.7	PWM AC IP20	37	MM501U	SCR Isolated Open Chassis	9
ACM114T-0.4	PWM AC IP20	37	MMXL02-D240AC	PWM DC Open Chassis	13
ACM114T-0.75	PWM AC IP20	37	MMXL02-D240AC-PCM	PWM Isolated DC Open Chassis	13
ACM114T-1.1	PWM AC IP20	37	MMXL05-D240AC	PWM DC Open Chassis	13
ACM114T-1.5	PWM AC IP20	37	MMXL05-D240AC-PCM	PWM Isolated DC Open Chassis	13
ACM114T-2.2	PWM AC IP20	37	MMXL10-D240AC	PWM DC Open Chassis	13
ACM114T-3.7	PWM AC IP20	37	MMXL10-D240AC-PCM	PWM Isolated DC Open Chassis	13
C1XP01-115AC-A	PWM NEMA 1 Enclosure	15	NRG02-D240AC-4Q	PWM Regen Chassis	27
C1XP03-115AC-A	PWM NEMA 1 Enclosure	15	NRG05-D240AC-4Q	PWM Regen Chassis	27
C4XL3025	PWM NEMA 4X Enclosure	14	NRG10-115AC-4Q	PWM Regen Chassis	27
C4XL3200A	PWM NEMA 4X Enclosure	14	NRG-PCM Series	PWM Isolated Regen Open Chassis	27
CE04XL	Reduces incoming noise	47	PCM21000A	SCR Isolated Open Chassis	8
CE15XL	Reduces incoming noise	47	PCM21010A	SCR Isolated Open Chassis	8
CE20MM	Reduces control noise	47	PCM22000A	SCR Isolated Open Chassis	8
CE20RG	Reduces control noise	47	PCM23001A	SCR Isolated Open Chassis	8
CE24PWM	Reduces incoming noise	47	PCM23401A	SCR Isolated NEMA 4X Enclosure	8
CE4MM	Reduces control noise	47	PCM23411A	SCR Isolated NEMA 4X Enclosure	8
CE4RG	Reduces control noise	47	PCM4	Isolation Card	45
DC1.5-12	PWM DC to DC Open Chassis	17	PCMXP02-115AC	PWM Isolated Open Chassis	15
DC1.4-24	PWM DC to DC Open Chassis	17	PCMXP05-115AC	PWM Isolated Open Chassis	15
DC16-12/24	PWM DC to DC Open Chassis	19	PCMXP10-115AC	PWM Isolated Open Chassis	15
DC240-12/24-4Q	PWM DC to DC Open Chassis	21	PK24	Encoder	44
DC250-12/24-4Q	PWM DC to DC Open Chassis	21	RD16U	SCR Open Chassis	11
DC30-12/24-4Q	PWM DC to DC Open Chassis	20	RG500A	SCR Regen NEMA 4X Enclosure	23
DC500N-4Q-36/38	PWM DC to DC Open Chassis	22	RG500UA	SCR Regen Open Chassis	23
DC60-12/24	PWM DC to DC Open Chassis	19	RG500UA-PCM	SCR Isolated Regen Open Chassis	23
DC60-36/48	PWM DC to DC Open Chassis	19	RG501A	SCR Regen NEMA 4X Enclosure	24
DLC600	Digital Control	42	RG510A	SCR Regen NEMA 4X Enclosure	23
HTL05-D-4Q	PWM Regen Open Chassis	16	RG510UA	SCR Regen Open Chassis	23
LV01-24AC	PWM DC Low Voltage	18	RG510UA-PCM	SCR Isolated Regen Open Chassis	23
LV02-24AC	PWM DC Low Voltage	18	RG511A	SCR Regen NEMA 4X Enclosure	24
LV02-24DC	PWM DC Low Voltage	18	RG5500U	SCR Isolated Regen Open Chassis	26
M1	SCR Open Chassis	6	RG60U	SCR Regen Open Chassis	25
M2	SCR Open Chassis	7	RG60U-PCM	SCR Isolated Regen Open Chassis	25
M2-D	SCR Open Chassis	7	RG60U-T	SCR Regen Open Chassis	25
MC10	SCR NEMA 4X Enclosure	12	RG61U	SCR Regen Open Chassis	25
MC10-PCM	SCR Isolated NEMA 4X Enclosure	12	RG61U-PCM	SCR Isolated Open Chassis	25
MC10-R	SCR NEMA 4X Enclosure Reversing	12	RG61U-T	SCR Open Chassis	25
MM03-115AC-PCM	SCR Isolated Open Chassis	10	SQ16U	SCR Open Chassis	11
MM03-230AC-PCM	SCR Isolated Open Chassis	10	SQ216U	SCR Open Chassis	11
MM10-115AC-PCM	SCR Isolated Open Chassis	10	TA10-D	Triac Open Chassis	34
MM10-230AC-PCM	SCR Isolated Open Chassis	10	VFD02-115AC	PWM AC Open Chassis	35



## Competitor Cross Reference

This page is a tool to help cross other DC drives to the Minarik Drives' line of DC drives. You will see brands such as KB Electronics, Dart Controls, Baldor, Bodine, Grainger, and Graham. This cross reference includes some of the more common drives from those manufacturers. Call the Minarik Drives factory at **800-MINARIK** to speak to an Application Engineer if your drive is not listed below or if you have any questions about the differences between the various drives.

### KB Electronics™ → Minarik Drives

KBBC Series	→	DC30-12/24-4Q
KBIC Series	→	MM23001C
KBMD Series	→	MM23101C or MM23201C
KBMG Series	→	RG60U
KBMM Series	→	MM23001C
KBPB Series	→	RG60U
KBSI-240D	→	PCM4
KBRG-212D	→	RG500UA
KBRG-240D	→	RG500UA
KBRG-255	→	RG5500U
KBWD Series	→	MMXL Series
SI Series	→	Models starting with "PCM"

### Grainger® → Minarik Drives

2M510	→	MM23001C
2M511	→	MC10
5JJ51	→	DC30-12/24-4Q
5JJ56	→	MM31750B
5JJ57	→	MM31750B
5JJ58	→	MM23101C
5JJ59	→	MM23021C
6Z385	→	MM23001C
6Z386	→	MC10
6Z387	→	MM23002D
6Z388	→	MC10

### Dart Controls™ → Minarik Drives

125DV-C	→	MM23001C or MM23001C-Q
15DV Series	→	MM31750B
253G-200C	→	MM23001C
253G-200E	→	MM23401C or MC10
530BC	→	MM23002D
530BRE	→	MC10
VSI	→	PCM4
MD Series	→	DLC600 & drive

### Graham™ → Minarik Drives

1400-C	→	MMXL02-D240AC
1450-C	→	MMXL02-D240AC
176B0089	→	PCM4
176B1111	→	MM23001C
176B1112	→	MM23001C
176B3001	→	RG60U
176B3002	→	RG500A
176B3003	→	RG60U
176B3004	→	RG500A
176B3005	→	RG60U
176B3006	→	RG60U
176B3007	→	RG60U
176B3008	→	RG60U
176B4000	→	RG500UA
176B4001	→	RG500UA
176B6000	→	RG500A
176B6001	→	RG500UA
176B6002	→	RG500UA
176B6003	→	RG5500U
176B6004	→	RG500UA
176B6005	→	RG5500U
176B8013	→	RG510UA

### Baldor® → Minarik Drives

BC140	→	MM23101C
BC140-FBR	→	MM23201C
BC141	→	MM23001C
BC142	→	MM23001C
BC155	→	MM501U
BC154	→	MC10
BCWD140	→	MC10-R
BC200	→	RG500UA
BC202	→	RG500UA
BC203	→	RG5500U
BC204	→	RG60U
BC254	→	RG500A
BC354	→	C4XL3200A

### Bodine® → Minarik Drives

0780	→	MMXL02-D240AC
0781	→	MMXL05-D240AC
0790	→	C1XP01-115AC-A
0791	→	C1XP03-115AC-A
0865	→	MM23001C
0867	→	MM23101C
1865	→	MC10

NOTES:

---

NOTES:

---

Visit our website at **www.minarikdrives.com**  
**your online resource** for Minarik Drives

Search by Part Number or Partial Part Number

Online Catalog

Find a Distributor

Search by Technology

Download Manuals

New Products

Company Overview Video

Contact us

**use our product specifier** to assist you in finding the right drive or motor for **your application.**

- SEARCH BY**
- Current
  - HP
  - Enclosure Type
  - Braking
  - Reversing
  - and more



Part # Search

Product Manuals Online Catalog Product Support Distributors Gearheads Accessories

Choose at least one field to begin a search. The more fields chosen, the more refined the results will be.

Continuous Current:

Horsepower @ 115:

Horsepower @ 230:

Braking:  Yes  No  No Preference

Reversing:  Yes  No  No Preference

Enclosure Type:

©2006 Minarik Corporation Xtranet / About Us / Contact

# Product Technologies

## DC Drives:

- Regenerative
- SCR
- PWM
- Digital
- NEMA Enclosure and Chassis Models

## Motors:

- DC Geared
- DC Non-Geared
- DC Permanent Magnet

## AC Drives:

- Programmable
- NEMA Enclosure, IP20 and Chassis Models



14300 DE LA TOUR DRIVE  
SOUTH BELOIT, IL 61080

Tel: 1-800-MINARIK (646-2745) | Fax: 1-815-624-6960 | email: [info@minarikdrives.com](mailto:info@minarikdrives.com) | [www.minarikdrives.com](http://www.minarikdrives.com)



MADE IN THE USA